

**50TC
Cooling Only/Electric Heat
Packaged Rooftop
3 to 15 Nominal Tons**

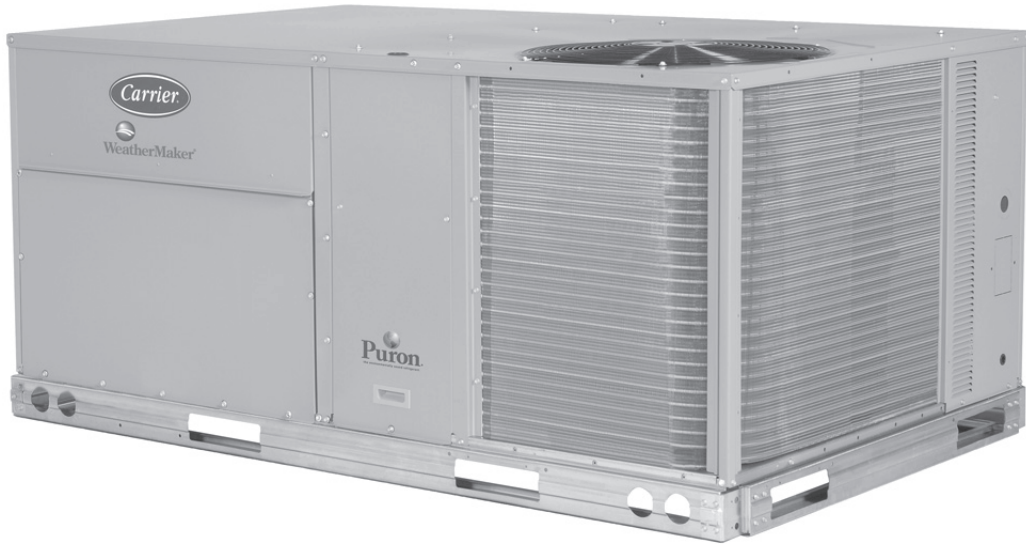

Product Data



C08613



TABLE OF CONTENTS

	PAGE		PAGE
FEATURES AND BENEFITS	3	APPLICATION DATA	27
MODEL NUMBER NOMENCLATURE	4	COOLING TABLES	30
FACTORY OPTIONS & ACCESSORIES	5	STATIC PRESSURE TABLES	51
AHRI CAPACITY RATING	9	FAN PERFORMANCE	54
SOUND PERFORMANCE	11	SEQUENCE OF OPERATION	168
PHYSICAL DATA	12	GUIDE SPECIFICATIONS	171
CURBS & WEIGHTS DIMENSIONS	15		



Turn to the Experts™

The Carrier rooftop unit (RTU) was designed by customers for customers. With no-strip screw collars, handled access panels, and more we've made your unit easy to install, easy to maintain and easy to use.

Easy to install:

All WeatherMaker™ units are field-convertible to horizontal air flow which makes it easy to adjust to unexpected job site complications. Lighter units make easy replacement. Most Carrier 50TC rooftops fit on existing Carrier curbs dating back to 1989. Also, our large control box gives you room to work and room to mount Carrier accessory controls.

Easy to maintain:

Easy access handles by Carrier provide quick and easy access to all normally serviced components. Our "no-strip" screw system has superior holding power and guides screws into position while preventing the screw from stripping the unit's metal. Take accurate pressure readings by reading condenser pressure with panels on. Simply remove the black, composite plug, route your gauge line(s) through the hole, and connect them to the refrigeration service valve(s).

Easy to use:

The newly designed, central terminal board by Carrier puts all your connections and troubleshooting points in one convenient place, standard. Most low voltage connections are made to the same board and make it easy to find what you're looking for and easy to access it. Carrier rooftops have high and low pressure switches, a filter drier, and 2-in (51mm) filters standard.

FEATURES AND BENEFITS

- Single-stage cooling capacity control on 04 to 12 models. Two-stage cooling capacity control on 08 to 16 models.
- SEER's up to 13.0.
- EER's up to 11.3.
- IEER's up to 12.2 with 1-speed indoor fan motor.
- IEER's up to 13.0 with 2-speed/VFD indoor fan motor.
- Up to 28% lighter than similar industry units. Lighter rooftops make easier replacement jobs.
- 3-12.5 ton units fit on existing Carrier rooftop curbs making the utility connections the same. This saves time and money on replacement jobs.
- Standardized components and layout. Standardized components and controls make service and stocking parts easier.
- Scroll compressors on all units. This makes service, stocking parts, replacement, and troubleshooting easier.
- Field convertible airflow (3-12.5 tons). Being able to convert a unit from vertical airflow to horizontal makes it easy to overcome job site complications. 15 ton models requires a simple supply duct cover to field convert from factory vertical to horizontal.
- Easy-adjust, belt-drive motor available. There's no need for field-supplied drives or motors.
- Provisions for bottom or side condensate drain.
- Capable of thru-the-base or thru-the-curb electrical routing.
- Single-point electrical connection.
- Sloped, composite drain pan sheds water; and won't rust.
- Standardized controls and control box layout. Standardized components and controls make stocking parts and service easier.
- Clean, large, easy to use control box.
- Color-coded wiring.
- Large, laminated wiring and power wiring drawings which are affixed to unit make troubleshooting easy.
- Single, central terminal board for test and wiring connections.
- Fast-access, handled, panels for easy access to the blower and blower motor, control box, and compressors.
- "No-strip" screw system guides screws into the panel and captures them tightly without stripping the screw, the panel, or the unit.
- Exclusive, newly-design indoor refrigerant header for easier maintenance and replacement.
- Mechanical cooling (115°F to 40°F or 46°C to 4°C) standard on all models. Winter start kit allows cooling operation down to 25°F (-4°C) and MotorMaster to -20°F (-29°C).
- 2-in (51mm) disposable filters on all units.
- Refrigerant filter-drier on each circuit.
- High and low pressure switches. Added reliability with high pressure switch and low pressure switch.
- Factory-installed Humidi-MiZer adaptive dehumidification system on all sizes with round tube/plate fin condenser coils, includes MotorMaster I controller.
- Optional Staged Air Volume (SAV) system utilizes a Variable Frequency Drive (VFD) to automatically adjust the indoor fan motor speed between cooling stages. Available on 2-stage cooling models 08-16 with electromechanical controls or RTU Open.

MODEL NUMBER NOMENCLATURE

1	2	3	4	5	6	7	8	9	10	11	12	13	14	15	16	17	18
5	0	T	C	-	A	0	4	A	1	A	5	-	0	A	0	A	0

Product Type

50 = Elect Heat Pkg. Rooftop

Model Series

TC = Standard Efficiency

Heat Size

- = No heat

Refrigerant System Options

A = 1-stage cooling models
 B = 1 stg cooling w/Humidi-MiZer (04-07)
 D = 2 stage Cooling (08-16)
 E = 2 stg cooling w/Al/Cu cond. coil and with Humidi-MiZer (08-16)

Cooling Tons

04 = 3 ton 08 = 7.5 ton
 05 = 4 ton 09 = 8.5 ton
 06 = 5 ton 12 = 10 ton
 07 = 6 ton 14 = 12.5 ton
 16 = 15 ton

Sensor Options

A = None
 B = RA Smoke Detector
 C = SA Smoke Detector
 D = RA + SA Smoke Detector
 E = CO₂ Sensor
 F = RA Smoke Detector + CO₂
 G = SA Smoke Detector + CO₂
 H = RA + SA Smoke Detector + CO₂

Indoor Fan Options

1 = Standard Static Option
 2 = Medium Static Option
 3 = High Static Option
 C = High Static Option w/Hi-Effy Motor (16 only)

Coil Options for round tube plate fin (RTPF) cond. models only (Outdoor-Indoor-Hail Guard)

A = Al/Cu - Al/Cu
 B = Pre-coat Al/Cu - Al/Cu
 C = E-coat Al/Cu - Al/Cu
 D = E-coat AL/Cu - E-coat AL/Cu
 E = Cu/Cu - Al/Cu
 F = Cu/Cu - Cu/Cu
 M = Al/Cu - Al/Cu - Louvered Hail Guard
 N = Pre-Coat Al/Cu - Al/Cu - Louvered Hail Guard
 P = E-Coat Al/Cu - Al/Cu Louvered Hail Guard
 Q = E-Coat Al/Cu - E-coat Al/Cu - Louvered Hail Guard
 R = Cu/Cu - Al/Cu - Louvered Hail Guard
 S = Cu/Cu - Cu/Cu - Louvered Hail Guard

Coil Options for all aluminum - Novation cond. models only (Outdoor-Indoor-Hail Guard)

G = Al/Al - Al/Cu
 H = Al/Al - Cu/Cu
 J = Al/Al - E-coat Al/Cu
 K = E-coat Al/Al - Al/Cu
 L = E-coat Al/Al - E-coat Al/Cu
 T = Al/Al - Al/Cu, Louvered Hail Guard
 U = Al/Al - Cu/Cu, Louvered Hail Guard
 V = Al/Al - E-coat Al/Cu, Louvered Hail Guard
 W = E-coat Al/Al - Al/Cu, Louvered Hail Guard
 X = E-coat Al/Al - E-coat Al/Cu, Louvered Hail Guard

Packaging

0 = Standard
 1 = LTL
 3 = CA Seismic Compliant
 4 = LTL & CA Seismic Compliant

Electrical Options

A = None
 C = Non-fused disconnect
 D = Thru the base connections
 F = Non-fused disconnect & thru the base
 G = 2-speed indoor fan (VFD) controller
 J = 2-spd contr (VFD) & non-fused disc.
 K = 2-spd contr (VFD) & thru the base
 M = 2-spd cont (VFD) non-fused disc. & thru the base connections

Service Options

0 = None
 1 = Un-powered Convenience Outlet
 2 = Powered Convenience Outlet
 3 = Hinged Panels
 4 = Hinged Panels, un-powered C.O.
 5 = Hinged Panels, powered C.O.

Intake / Exhaust Options

A = None
 B = Temperature Economizer w/Barometric Relief
 F = Enthalpy Economizer w/Barometric Relief
 K = 2 position Damper
 U = Temp Ultra Low Leak Economizer w/Baro Relief
 W = Enthalpy Ultra Low Leak Econo w/Baro Relief

Base Unit Controls

0 = Base Electromechanical Controls
 1 = PremierLink Controller
 2 = RTU Open Multi-Protocol Controller
 6 = Electromechanical with 2 speed fan and W7220 Econo controller

Design Revision

= Factory Design Revision

Voltage

1 = 575/3/60
 3 = 208-230/1/60
 5 = 208-230/3/60
 6 = 460/3/60

Note: On single phase (-3 voltage code) models, the Following are not available as a factory installed option:

- Humidi-Mizer
- Coated Coils or CU Fin Coils
- Louvered Hail Guards
- Economizer or 2 Position Damper
- Powered 115 Volt Convenience Outlet

Not all possible options can be displayed above - see price pages or contact your Carrier Expert for more details.

Table 1 – FACTORY-INSTALLED OPTIONS AND FIELD-INSTALLED ACCESSORIES

CATEGORY	ITEM	FACTORY INSTALLED OPTION	FIELD INSTALLED ACCESSORY
Cabinet	Supply Duct Cover (16 size only)		X
	Thru-the-base electrical connections	X	X
	California Seismic Compliant Labeling	X	
	Hinged Access Panels	X	
Coil Options	Cu/Cu indoor and/or outdoor coils ^{1, 6}	X	
	Pre-coated outdoor coils ^{1, 6}	X	
	Premium, E-coated outdoor coils ^{1, 6}	X	
Humidity Control	Humidi-MiZer Adaptive Dehumidification System ⁶	X	
Condenser Protection	Condenser coil hail guard (louvered design) ⁶	X	X
Controls	Thermostats, temperature sensors, and subbases		X
	PremierLink DDC communicating controller	X	X
	RTU Open –protocol controller	X	
	Smoke detector (supply and/or return air)	X	
	Time Guard II compressor delay control circuit		X
	Phase Monitor		X
Economizers & Outdoor Air Dampers	EconoMi\$er IV (for electromechanical controlled RTUs) ⁶	X	X
	EconoMi\$er2 (for DDC controlled RTUs) ⁶	X	X
	Motorized 2 position outdoor –air damper ⁶	X	X
	Manual outdoor –air damper (25% and 50%)		X
	Barometric relief ²	X	X
	Power exhaust		X
	Ultra Low Leak EconoMi\$er X (for 2 –speed SAV system only 08 to 16 sizes with 2 stages of cooling), vertical supply and return air only.	X	X
Economizer Sensors & IAQ Devices	Single dry bulb temperature sensors ³	X	X
	Differential dry bulb temperature sensors ³		X
	Single enthalpy sensors ³	X	X
	Differential enthalpy sensors ³		X
	CO ₂ sensor (wall, duct, or unit mounted) ³	X	X
Electric Heat	Electric Resistance Heaters		X
	Single Point Kit		X
Indoor Motor & Drive	Multiple motor and drive packages	X	
	Staged Air Vol (SAV) system w/VFD controller (2 –stage cool only with electrical mechanical and RTU Open controls)	X	
	Display Kit for SAV system with VFD		X
Low Ambient Control	Winter start kit ⁴		X
	Motormaster® head pressure controller ⁴		X
Power Options	Convenience outlet (powered) ⁶	X	
	Convenience outlet (unpowered)	X	
	Non –fused disconnect ⁵	X	
	Disconnect Switch Bracket (16 size only)		X
Roof Curbs	Roof curb 14 –in (356mm)		X
	Roof curb 24 –in (610mm)		X

NOTES:

1. Novation coated coils are only available with E-coat.
2. Included with economizer.
3. Sensors for optimizing economizer.
4. See application data for assistance.
5. Available on units with MOCP's of 80 amps or less.
6. Not available as factory installed option on single phase (208/230/1/60) models. Use field-installed accessory where available.

FACTORY OPTIONS AND/OR ACCESSORIES

Economizer (dry-bulb or enthalpy)

Economizers save money. They bring in fresh, outside air for ventilation; and provide cool, outside air to cool your building. This is the preferred method of low ambient cooling. When coupled to CO₂ sensors, Economizers can provide even more savings by coupling the ventilation air to only that amount required.

Economizers are available, installed and tested by the factory, with either enthalpy or dry-bulb temperature inputs. There are also models for electromechanical as well as direct digital controllers. Additional sensors are available as accessories to optimize the economizers.

Economizers include gravity controlled, barometric relief which equalizes building pressure and ambient air pressures. This can be a cost effective solution to prevent building pressurization.

CO₂ Sensor

Improves productivity and saves money by working with the economizer to intake only the correct amount of outside air for ventilation. As occupants fill your building, the CO₂ sensor detects their presence through increasing CO₂ levels, and opens the economizer appropriately.

When the occupants leave, the CO₂ levels decrease, and the sensor appropriately closes the economizer. This intelligent control of the ventilation air, called Demand Control Ventilation (DCV) reduces the overall load on the rooftop, saving money.

Smoke Detectors

Trust the experts. Smoke detectors make your application safer and your job easier. Carrier smoke detectors immediately shut down the rooftop unit when smoke is detected. They are available, installed by the factory, for supply air, return air, or both.

Louvered Hail Guards

Sleek, louvered panels protect the condenser coil from hail damage, foreign objects, and incidental contact.

Convenience Outlet (powered or un-powered)

Reduce service and/or installation costs by including a convenience outlet in your specification. Carrier will install this service feature at our factory. Provides a convenient, 15 amp, 115v GFCI receptacle with “Wet in Use” cover. The “powered” option allows the installer to power the outlet from the line side of the disconnect or load side as required by code. The “unpowered” option is to be powered from a separate 115/120v power source.

Non-fused Disconnect

This OSHA-compliant, factory-installed, safety switch allows a service technician to locally secure power to the rooftop.

Disconnect Switch Bracket

Provides a pre-engineered and sized mounting bracket for applications requiring a unit mounted fused and non-fused disconnect of greater than 100 amps. Bracket assures that no damage will occur to coils when mounting with screws and other fasteners (16 size only).

Power Exhaust with Barometric Relief

Superior internal building pressure control. This field-installed accessory may eliminate the need for costly, external pressure control fans.

PremierLink

This CCN controller regulates your rooftop’s performance to tighter tolerances and expanded limits, as well as facilitates zoning systems and digital accessories. It also unites your Carrier HVAC equipment together on one, coherent CCN network. The PremierLink can be factory-installed, or easily field-installed. Not available with 2-speed Staged Air Volume (SAV) System.

RTU Open, Multi-protocol Controller

Connect the rooftop to an existing BAS without needing complicated translators or adapter modules using the RTU Open controller. This new controller speaks the 4 most common building automation system languages (Bacnet, Modbus, N2, and Lonworks). Use this controller when you have an existing BAS.

Time Guard II Control Circuit

This accessory protects your compressor by preventing short-cycling in the event of some other failure, prevents the compressor from restarting for 30 seconds after stopping. Not required with PremierLink, RTU Open, or authorized commercial thermostats.

Filter or Fan Status Switches

Use these differential pressure switches to detect a filter clog or indoor fan motor failure. When used in conjunction with a compatible unit controller/thermostat, the switches will activate an alarm to warn the appropriate personnel.

Motorized 2-Position Damper

The new Carrier 2-position, motorized outdoor air damper admits up to 100% outside air. Using reliable, gear-driven technology, the 2-position damper opens to allow ventilation air and closes when the rooftop stops, stopping unwanted infiltration.

Manual OA Damper

Manual outdoor air dampers are an economical way to bring in ventilation air. The dampers are available in 25% and 50% versions.

FACTORY OPTIONS AND/OR ACCESSORIES (cont.)

Optional Humidi-MiZer Adaptive Dehumidification System

Carrier's Humidi-MiZer adaptive dehumidification system is an all-inclusive factory-installed option that can be ordered with any WeatherMaker 50TC-04-16 rooftop unit.

This system expands the envelope of operation of Carrier's WeatherMaker rooftop products to provide unprecedented flexibility to meet year-round comfort conditions.

The Humidi-MiZer adaptive dehumidification system has the industry's only dual dehumidification mode setting. The Humidi-MiZer system includes two new modes of operation.

The WeatherMaker 50TC-04-16 rooftop coupled with the Humidi-MiZer system is capable of operating in normal design cooling mode, subcooling mode, and hot gas reheat mode. Normal design cooling mode is when the unit will operate under its normal sequence of operation by cycling compressors to maintain comfort conditions.

Subcooling mode will operate to satisfy part load type conditions when the space requires combined sensible and a higher proportion of latent load control. Hot Gas Reheat mode will operate when outdoor temperatures diminish and the need for latent capacity is required for sole humidity control. Hot Gas Reheat mode will provide neutral air for maximum dehumidification operation.

Staged Air Volume (SAV) Indoor Fan Speed System

Carrier's Staged Air Volume (SAV) system saves energy and installation time by utilizing a Variable Frequency Drive (VFD) to automatically adjust the indoor fan motor speed in sequence with the units cooling operation. Per ASHRAE 90.1 2010 standard section 6.4.3.10.b, during the first stage of cooling operation the VFD will adjust the fan motor to provide 2/3rd of the total cfm established for the unit. When a call for the second stage of cooling is required, the VFD will allow the total cfm for the unit established (100%). During the heating mode the VFD will allow total design cfm (100%) operation and during the ventilation mode the VFD will allow operation to 2/3rd of total cfm.

Compared to 1-speed indoor fan motor systems, Carrier's SAV system can save substantial energy, 25%+*, versus 1-speed indoor fan motor systems.

The VFD used in Carrier's SAV system has soft start capabilities to slowly ramp up the speeds, thus eliminating any high inrush air volume during initial start-up. It also has internal over-current protection for the fan motor and a field installed display kit that allows adjustment and in depth diagnostics of the VFD.

This SAV system is available on models with 2-stage cooling operation with electromechanical or RTU Open, Multi Protocol controls. Both space sensor and

conventional thermostats/controls can be used to provide accurate control in any application.

The SAV system is very flexible for initial fan performance set up and adjustment. The standard factory shipped VFD is pre-programmed to automatically stage the fan speed between the first and second stage of cooling. The unit fan performance static pressure and cfm can be easily adjusted using the traditional means of pulley adjustments. The other means to adjust the unit static and cfm performance is to utilize the field installed Display Kit and adjust the frequency and voltage in the VFD to performance requirements. In either case, once set up, the VFD will automatically adjust the speed between the cooling stage operations.

*Data based on .10 (\$/kWh) utilizing Carrier's HAP 4.6 simulation software program

Motormaster Head Pressure Controller

The Motormaster motor controller is a low ambient, head pressure controller kit that is designed to maintain the unit's condenser head pressure during periods of low ambient cooling operation. This device should be used as an alternative to economizer free cooling when economizer usage is either not appropriate or desired. The Motormaster will either cycle the outdoor fan motors or operate them at reduced speed to maintain the unit operation, depending on the model.

Hinged Access Panels

Allows access to unit's major components with specifically designed hinged access panels. Panels are: filters, control box, fan motor and compressor.

Winter Start Kit

The winter start kit by Carrier extends the low ambient limit of your rooftop to 25°F (-4°C). The kit bypasses the low pressure switch, preventing nuisance tripping of the low pressure switch. Other low ambient precautions may still be prudent.

Alternate Motors and Drives

Some applications need larger horsepower motors, some need more airflow, and some need both. Regardless of the case, your Carrier expert has a factory installed combination to meet your application. A wide selection of motors and pulleys (drives) are available, factory installed, to handle nearly any application.

Thru-the-Base Connections

Thru-the-base connections, available as either an accessory or as a factory option, are necessary to ensure proper connection and seal when routing wire and piping through the rooftop's basepan and curb. These couplings eliminate roof penetration and should be considered for gas lines, main power lines, as well as control power.

FACTORY OPTIONS AND/OR ACCESSORIES (cont.)

Electric Heaters

Carrier offers a full-line of field-installed accessory heaters. The heaters are very easy to use, install and are all pre-engineered and certified.

Supply Duct Cover

This supply duct cover is required when field converting the factory standard vertical duct supply to horizontal duct supply configuration. One required per unit (16 size only).

California OSHPD Seismic Certification Label

Units meet the seismic requirements of the International Code Council Evaluation Service (ICC-ES) document AC156 (Acceptance Criteria for Seismic Qualification by Shake-Table Testing of Nonstructural Components and Systems) and per International Building Code (IBC 2009) at an SDS (g) value of 2.00 z/h=1.0, Ip=1.5 and certified by independent structural engineers. A certification label is applied to the unit that meets the CA OSHPD Special Seismic Certification pre-approval labeling requirements on the external chassis of the unit.

Table 2 – AHRI COOLING RATING TABLES

UNIT	COOLING STAGES	NOM. CAPACITY (TONS)	NET COOLING CAPACITY (MBH)	TOTAL POWER (KW)	SEER	EER	IEER
A04	1	3	34.6	3.1	13.00	11.00	N/A
A05	1	4	45.0	4.0	13.00	11.00	N/A
A06	1	5	59.0	5.5	13.00	10.75	N/A
A07	1	6	70.0	6.4	N/A	11.20	11.4
A08	1	7.5	88.0	8.0	N/A	11.20	11.4
A09	1	8.5	97.0	8.8	N/A	11.20	11.4
A12	1	10	117.0	10.6	N/A	11.20	11.4

UNIT	COOLING STAGES	NOM. CAPACITY (TONS)	NET COOLING CAPACITY (MBH)	TOTAL POWER (KW)	EER	IEER WITH 1-SPEED INDOOR FAN MOTOR	IEER WITH 2-SPEED INDOOR FAN MOTOR
D08	2	7.5	83.0	7.4	11.20	11.7	13.0
D09	2	8.5	99.0	8.8	11.20	11.7	13.0
D12	2	10	114.0	10.1	11.30	12.2	13.0
D14	2	12.5	140.0	12.7	11.00	11.2	12.0
D16	2	15	174.0	15.8	11.00	11.5	12.6

LEGEND

- AHRI – Air Conditioning, Heating and Refrigeration Institute
- ASHRAE – American Society of Heating, Refrigerating and Air Conditioning, Inc.
- EER – Energy Efficiency Ratio
- IEER – Integrated Energy Efficiency Ratio
- SEER – Seasonal Energy Efficiency Ratio

NOTES

1. Rated and certified under AHRI Standard 210/240 or 340/360, as appropriate.
2. Ratings are based on:
Cooling Standard: 80°F (27°C) db, 67°F (19°C) wb indoor air temp and 95°F db outdoor air temp.
IEER Standard: A measure that expresses cooling part-load EER efficiency for commercial unitary air conditioning and heat pump equipment on the basis of weighted operation at various load capacities.
3. All 50TC units comply with ASHRAE 90.1 Energy Standard for minimum SEER and EER requirements.
4. Where appropriate, 50TC units comply with US Energy Policy Act (2005). Refer to state and local codes.



Use of the AHRI Certified TM Mark indicates a manufacturer's participation in the program. For verification of certification for individual products, go to www.ahridirectory.org.

Table 3 – MINIMUM - MAXIMUM AIRFLOWS COOLING AND ELECTRIC HEAT

UNIT	COOLING				ELECTRIC HEATERS	
	Minimum Single Speed Fan Motor	Minimum 2-speed Fan Motor (at high speed)	Minimum 2-speed Fan Motor (at low speed)	Maximum	Minimum	Maximum
50TC**04	900	–	–	1500	900	1500
50TC**05	1200	–	–	2000	1200	2000
50TC**06	1500	–	–	2500	1500	2500
50TC**07	1800	–	–	3000	1800	3000
50TC**08	2250	2250	1485	3750	2250*	3750
50TC**09	2550	2873	1896	4250	2550*	4250
50TC**12	3000	3380	2231	5000	3000*	5000
50TC**14	3600	4225	2789	6000	3000*	6000
50TC**16	4500	5625	3713	7500	4500	7500

* Minimum electric heat CFM exceptions :

UNIT	UNIT VOLTAGE	HEATER KW	UNIT CONFIGURATION	REQUIRED MINIMUM CFM
50TC**12 50TC**14	208/230	42.4	Horizontal	3200
50TC**12 50TC**14	208/230	50.0	Horizontal	3200
50TC**12 50TC**14	460	50.0	Horizontal or Vertical	3200
50TC**08	575	17.0	Horizontal or Vertical	2800
50TC**09 50TC**12 50TC**14	575	34.0	Horizontal or Vertical	2350

Table 4 – SOUND PERFORMANCE TABLE

UNIT	COOLING STAGES	OUTDOOR SOUND (dB)								
		A-WEIGHTED	63	125	250	500	1000	2000	4000	8000
A04	1	80	90.6	80.9	80.2	76	74.6	71.3	68.5	63.9
A05	1	81	90.9	84.6	79.5	77.9	76.5	71.1	66.9	62.5
A06	1	78	84.0	82.2	76.3	74.8	72.5	68.8	65.6	61.8
A07	1	78	88.8	81.8	76.9	74.4	73.3	69.8	66.3	62.7
A08	1	82	90.1	82.6	81.0	79.4	77.0	73.0	70.4	66.7
D08	2	82	85.8	84.3	80.5	78.7	76.4	72.7	68.3	65.1
A09	1	83	91.2	86.4	81.9	81.0	78.3	73.9	71.4	67.3
D09	2	82	88.6	85.0	81.6	79.5	77.4	74.1	71.0	66.3
A12	1	82	88.6	85.0	81.6	79.5	77.4	74.1	71.0	66.3
D12	2	82	89.0	83.1	80.5	78.5	75.5	71.6	69.6	69.3
D14	2	87	87.0	85.2	84.6	84.9	82.2	78.4	75.3	72.9
D16	2	87	87.0	85.2	84.6	84.9	82.2	78.4	75.3	72.9

LEGEND

dB – Decibel



NOTES:

1. Outdoor sound data is measure in accordance with AHRI standard 270–2008.
2. Measurements are expressed in terms of sound power. Do not compare these values to sound pressure values because sound pressure accounts for specific environmental factors which do not match individual applications. Sound power values are independent of the environment and therefore more accurate.
3. A-weighted sound ratings filter out very high and very low frequencies, to better approximate the response of an “average” human ear. A-weighted measurements for Carrier units are taken in accordance with 270–2008.

Table 5 – PHYSICAL DATA

(COOLING)

3 - 6 TONS

		50TC*A04	50TC*A05	50TC*A06	50TC*A07
Refrigeration System					
# Circuits / # Comp. / Type		1 / 1 / Scroll	1 / 1 / Scroll	1 / 1 / Scroll	1 / 1 / Scroll
Puron® refig. (R-410A) (lbs-oz)		5-10	8-8	10-11	14-2
Humidi-MiZer Puron® refig. charge A/B (lbs - oz)		8-11	14-13	16-0	22-5
Metering Device		Acutrol	Acutrol	Acutrol	Acutrol
High-press. Trip / Reset (psig)		630 / 505	630 / 505	630 / 505	630 / 505
Low-press. Trip / Reset (psig)		54 / 117	54 / 117	54 / 117	54 / 117
Compressor Capacity Staging (%)		100%	100%	100%	100%
Evap. Coil					
Material (Tube/Fin)		Cu / Al	Cu / Al	Cu / Al	Cu / Al
Coil type		3/8-in RTPF	3/8-in RTPF	3/8-in RTPF	3/8-in RTPF
Rows / FPI		2 / 15	2 / 15	4 / 15	4 / 15
Total Face Area (ft ²)		5.5	5.5	5.5	7.3
Condensate Drain Conn. Size		3/4-in	3/4-in	3/4-in	3/4-in
Evap. Fan and Motor					
Standard Static 1 phase	Motor Qty / Drive Type	1 / Belt	1 / Belt	1 / Belt	-
	Max BHP	1.2	1.2	1.2	-
	RPM Range	560-854	560-854	770-1175	-
	Motor Frame Size	48	48	48	-
	Fan Qty / Type	1 / Centrifugal	1 / Centrifugal	1 / Centrifugal	-
	Fan Diameter (in)	10 x 10	10 x 10	10 x 10	-
Medium Static 1 phase	Motor Qty / Drive Type	1 / Belt	1 / Belt	1 / Belt	-
	Max BHP	1.2	1.2	1.5	-
	RPM Range	770-1175	770-1175	1035-1466	-
	Motor Frame Size	48	48	56	-
	Fan Qty / Type	1 / Centrifugal	1 / Centrifugal	1 / Centrifugal	-
	Fan Diameter (in)	10 x 10	10 x 10	10 x 10	-
Standard Static 3 phase	Motor Qty / Drive Type	1 / Belt	1 / Belt	1 / Belt	1 / Belt
	Max BHP	1.2	1.2	1.5	2.4
	RPM Range	560-854	560-854	770-1175	1073-1457
	Motor Frame Size	48	48	48	56
	Fan Qty / Type	1 / Centrifugal	1 / Centrifugal	1 / Centrifugal	1 / Centrifugal
	Fan Diameter (in)	10 x 10	10 x 10	10 x 10	10 x 10
Medium Static 3 phase	Motor Qty / Drive Type	1 / Belt	1 / Belt	1 / Belt	1 / Belt
	Max BHP	1.2	1.2	2.4	2.9*
	RPM Range	770-1175	770-1175	1035-1466	1173-1518
	Motor Frame Size	48	48	56	56
	Fan Qty / Type	1 / Centrifugal	1 / Centrifugal	1 / Centrifugal	1 / Centrifugal
	Fan Diameter (in)	10 x 10	10 x 10	10 x 10	10 x 10
High Static 3 phase	Motor Qty / Drive Type	1 / Belt	1 / Belt	1 / Belt	1 / Belt
	Max BHP	2.4	2.4	2.9	3.7
	RPM Range	1035-1466	1035-1466	1303-1687	1474-1788
	Motor Frame Size	56	56	56	56
	Fan Qty / Type	1 / Centrifugal	1 / Centrifugal	1 / Centrifugal	1 / Centrifugal
	Fan Diameter (in)	10 x 10	10 x 10	10 x 10	10 x 10
Cond. Coil					
Material (Tube/Fin)		Cu / Al	Cu / Al	Cu / Al	Cu / Al
Coil type		3/8-in RTPF	3/8-in RTPF	3/8-in RTPF	3/8-in RTPF
Rows / FPI		1 / 17	2 / 17	2 / 17	2 / 17
Total Face Area (ft ²)		14.6	16.5	16.5	21.3
Humidi-MiZer Coil					
Material (Tube/Fin)		Cu / Al	Cu / Al	Cu / Al	Cu / Al
Rows..Fins/in.		1 / 17	2 / 17	2 / 17	2 / 17
Total Face Area (ft ²)		3.9	3.9	3.9	5.2
Cond. fan / motor					
Qty / Motor Drive Type		1/ Direct	1/ Direct	1/ Direct	1/ Direct
Motor HP / RPM		1/4 / 1100	1/4 / 1100	1/4 / 1100	1/4 / 1100
Fan diameter (in)		22	22	22	22
Filters					
RA Filter # / Size (in)		2 / 16 x 25 x 2	2 / 16 x 25 x 2	2 / 16 x 25 x 2	4 / 16 x 16 x 2
OA inlet screen # / Size (in)		1 / 20 x 24 x 1	1 / 20 x 24 x 1	1 / 20 x 24 x 1	1 / 20 x 24 x 1

NOTE: Humidi-MiZer is not available with Novation condenser coil models, only Round Tube / Plate Fin (RTPF).

* 575V motor utilizes 3.7 BHP.

Table 5 - PHYSICAL DATA (cont.)

(COOLING)

7.5 - 8.5 TONS

		50TC*A08	50TC*D08	50TC*A09	50TC*D09
Refrigeration System					
# Circuits / # Comp. / Type		1 / 1 / Scroll	2 / 2 / Scroll	1 / 1 / Scroll	2 / 2 / Scroll
RTPF models R-410a charge A/B (lbs - oz)		13 - 12	8 - 5 / 8 - 2	15 - 4	10 - 5 / 10 - 12
Alternate (MCHX) R-410a charge A/B (lbs - oz)			4 - 6 / 4 - 6		
Alternate (Humidi-MiZer) R-410a charge A/B (lbs - oz)			13 - 3 / 13 - 3		16 - 13 / 16 - 13
Metering device		Acutrol	Acutrol	Acutrol	Acutrol
High - press. Trip / Reset (psig)		630 / 505	630 / 505	630 / 505	630 / 505
Low - press. Trip / Reset (psig)		54 / 117	54 / 117	54 / 117	54 / 117
Compressor Capacity Staging (%)		100%	50% / 100%	100%	50% / 100%
Evap. Coil					
Material		Cu / Al	Cu / Al	Cu / Al	Cu / Al
Coil type		3/8-in RTPF	3/8-in RTPF	3/8-in RTPF	3/8-in RTPF
Rows / FPI		3 / 15	3 / 15	3 / 15	3 / 15
Total face area (ft ²)		8.9	8.9	11.1	11.1
Condensate drain conn. size		3/4-in	3/4-in	3/4-in	3/4-in
Humidi-MiZer Coil					
Material		-	Cu / Al	-	Cu / Al
Coil type		-	3/8-in RTPF	-	3/8-in RTPF
Rows / FPI		-	2 / 17	-	2 / 17
Total face area (ft ²)		-	6.3	-	8.4
Evap. fan and motor					
Standard Static 3 phase	Motor Qty / Drive Type	1 / Belt	1 / Belt	1 / Belt	1 / Belt
	Max BHP	1.7	1.7	1.7	1.7
	RPM range	489-747	489-747	518-733	518-733
	Motor frame size	56	56	56	56
	Fan Qty / Type	1 / Centrifugal	1 / Centrifugal	1 / Centrifugal	1 / Centrifugal
	Fan Diameter (in)	15 x 15	15 x 15	15 x 15	15 x 15
Medium Static 3 phase	Motor Qty / Drive type	1 / Belt	1 / Belt	1 / Belt	1 / Belt
	Max BHP	2.9	2.9	2.4	2.4
	RPM range	733-949	733-949	690-936	690-936
	Motor frame size	56	56	56	56
	Fan Qty / Type	1 / Centrifugal	1 / Centrifugal	1 / Centrifugal	1 / Centrifugal
	Fan Diameter (in)	15 x 15	15 x 15	15 x 15	15 x 15
High Static 3 phase	Motor Qty / Drive type	1 / Belt	1 / Belt	1 / Belt	1 / Belt
	Max BHP	4.7	4.7	3.7	3.7
	RPM range	909-1102	909-1102	838-1084	838-1084
	Motor frame size	14	14	56	56
	Fan Qty / Type	1 / Centrifugal	1 / Centrifugal	1 / Centrifugal	1 / Centrifugal
	Fan Diameter (in)	15 x 15	15 x 15	15 x 15	15 x 15
Cond. Coil					
Material		Cu / Al	Cu / Al	Cu / Al	Cu / Al
Coil type		3/8-in RTPF	3/8-in RTPF	3/8-in RTPF	3/8-in RTPF
Rows / FPI		2 / 17	2 / 17	2 / 17	2 / 17
Total face area (ft ²)		20.5	20.5	21.4	25.1
Alternate (MCHX) Cond. Coil					
Material		-	Al / Al	-	-
Coil type		-	Novation™	-	-
Rows / FPI		-	1 / 20	-	-
Total face area (ft ²)		-	20.5	-	-
Cond. fan / motor					
Qty / Motor drive type		2 / direct	2 / direct	2 / direct	2 / direct
Motor HP / RPM		1/4 / 1100	1/4 / 1100	1/4 / 1100	1/4 / 1100
Fan diameter (in)		22	22	22	22
Filters					
RA Filter # / Size (in)		4 / 16 x 20 x 2	4 / 16 x 20 x 2	4 / 16 x 20 x 2	4 / 16 x 20 x 2
OA inlet screen # / Size (in)		1 / 20 x 24 x 1	1 / 20 x 24 x 1	1 / 20 x 24 x 1	1 / 20 x 24 x 1

NOTE: Humidi-MiZer is not available with Novation condenser coil models, only Round Tube/Plate Fin (RTPF).

Table 5 - PHYSICAL DATA (cont.)

(COOLING)

10 - 15 TONS

		50TC*A12	50TC*D12	50TC*D14	50TC*D16
Refrigeration System					
# Circuits / # Comp. / Type		1 / 1 / Scroll	2 / 2 / Scroll	2 / 2 / Scroll	2 / 2 / Scroll
RTPF models R-410a charge A/B (lbs - oz)		20 - 0	10 - 5 / 10 - 3	11 - 0 / 11 - 6	15 - 14/16 - 12
Alternate (MCHX) R-410a charge A/B (lbs - oz)		-	6 - 0 / 6 - 0	7 - 6 / 8 - 0	-
Alternate (Humidi-MiZer) R-410a charge A/B (lbs - oz)		-	16 - 10 / 16 - 0	17 - 10 / 18 - 3	-
Metering device		Acutrol	Acutrol	Acutrol	Acutrol
High - press. Trip / Reset (psig)		630 / 505	630 / 505	630 / 505	630 / 505
Low - press. Trip / Reset (psig)		54 / 117	54 / 117	54 / 117	54 / 117
Compressor Capacity Staging (%)		100%	50% / 100%	50% / 100%	50% / 100%
Evap. Coil					
Material		Cu / Al	Cu / Al	Cu / Al	Cu / Al
Coil type		3/8-in RTPF	3/8-in RTPF	3/8-in RTPF	3/8-in RTPF
Rows / FPI		4 / 15	4 / 15	4 / 15	3 / 15
Total face area (ft ²)		11.1	11.1	11.1	17.5
Condensate drain conn. size		3/4-in	3/4-in	3/4-in	3/4-in
Humidi-MiZer Coil					
Material		-	Cu / Al	Cu / Al	Cu / Al
Coil type		-	3/8-in RTPF	3/8-in RTPF	3/8-in RTPF
Rows / FPI		-	2 / 17	2 / 17	1 / 17
Total face area (ft ²)		-	8.4	8.4	13.8
Evap. fan and motor					
Standard Static 3 phase	Motor Qty / Drive type	1 / Belt	1 / Belt	1 / Belt	1 / Belt
	Max BHP	2.4	2.4	2.9	2.9
	RPM range	591-838	591-838	652-843	507-676
	Motor frame size	56	56	56	56
	Fan Qty / Type	1 / Centrifugal	1 / Centrifugal	1 / Centrifugal	1 / Centrifugal
	Fan Diameter (in)	15 x 15	15 x 15	15 x 15	18 x 18
Medium Static 3 phase	Motor Qty / Drive type	1 / Belt	1 / Belt	1 / Belt	1 / Belt
	Max BHP	3.7	3.7	3.7	3.7
	RPM range	838-1084	838-1084	838-1084	627-851
	Motor frame size	56	56	56	56
	Fan Qty / Type	1 / Centrifugal	1 / Centrifugal	1 / Centrifugal	1 / Centrifugal
	Fan Diameter (in)	15 x 15	15 x 15	15 x 15	18 x 18
High Static 3 phase	Motor Qty / Drive type	1 / Belt	1 / Belt	1 / Belt	1 / Belt
	Max BHP	4.7	4.7	4.7	6.1
	RPM range	1022-1240	1022-1240	1022-1240	776-955
	Motor frame size	14	14	14	S184T
	Fan Qty / Type	1 / Centrifugal	1 / Centrifugal	1 / Centrifugal	1 / Centrifugal
	Fan Diameter (in)	15 x 15	15 x 15	15 x 15	18 x 18
Cond. Coil					
Material		Cu / Al	Cu / Al	Cu / Al	Cu / Al
Coil type		3/8-in RTPF	3/8-in RTPF	3/8-in RTPF	3/8-in RTPF
Rows / FPI		2 / 17	2 / 17	3 / 17	2/17
Total face area (ft ²)		25.1	25.1	25.1	2 @ 23.1
Alternate (MCHX) Cond. Coil					
Material		-	Al / Al	Al / Al	-
Coil type		-	Novation™	Novation™	-
Rows / FPI		-	1 / 20	2 / 20	-
Total face area (ft ²)		-	25.1	25.1	-
Cond. fan / motor					
Qty / Motor drive type		2 / direct	2 / direct	1 / direct	3 / direct
Motor HP / RPM		1/4 / 1100	1/4 / 1100	1 / 1175	1/4 / 1100
Fan diameter (in)		22	22	30	22
Filters					
RA Filter # / Size (in)		4 / 20 x 20 x 2	4 / 20 x 20 x 2	4 / 20 x 20 x 2	6 / 18 x 24 x 2 2 / 24 x 27 x 1 (vert.)
OA inlet screen # / Size (in)		1 / 20 x 24 x 1	1 / 20 x 24 x 1	1 / 20 x 24 x 1	1 / 30 x 39 x 1 (horiz)

NOTE: Humidi-MiZer is not available with Novation condenser coil models, only Round Tube/Plate Fin (RTPF) up to 16 size.

CURBS, WEIGHTS & DIMENSIONS

NOTES:

1. DIMENSIONS ARE IN INCHES, DIMENSIONS IN () ARE IN MILLIMETERS.
2. CENTER OF GRAVITY
3. DIRECTION OF AIR FLOW

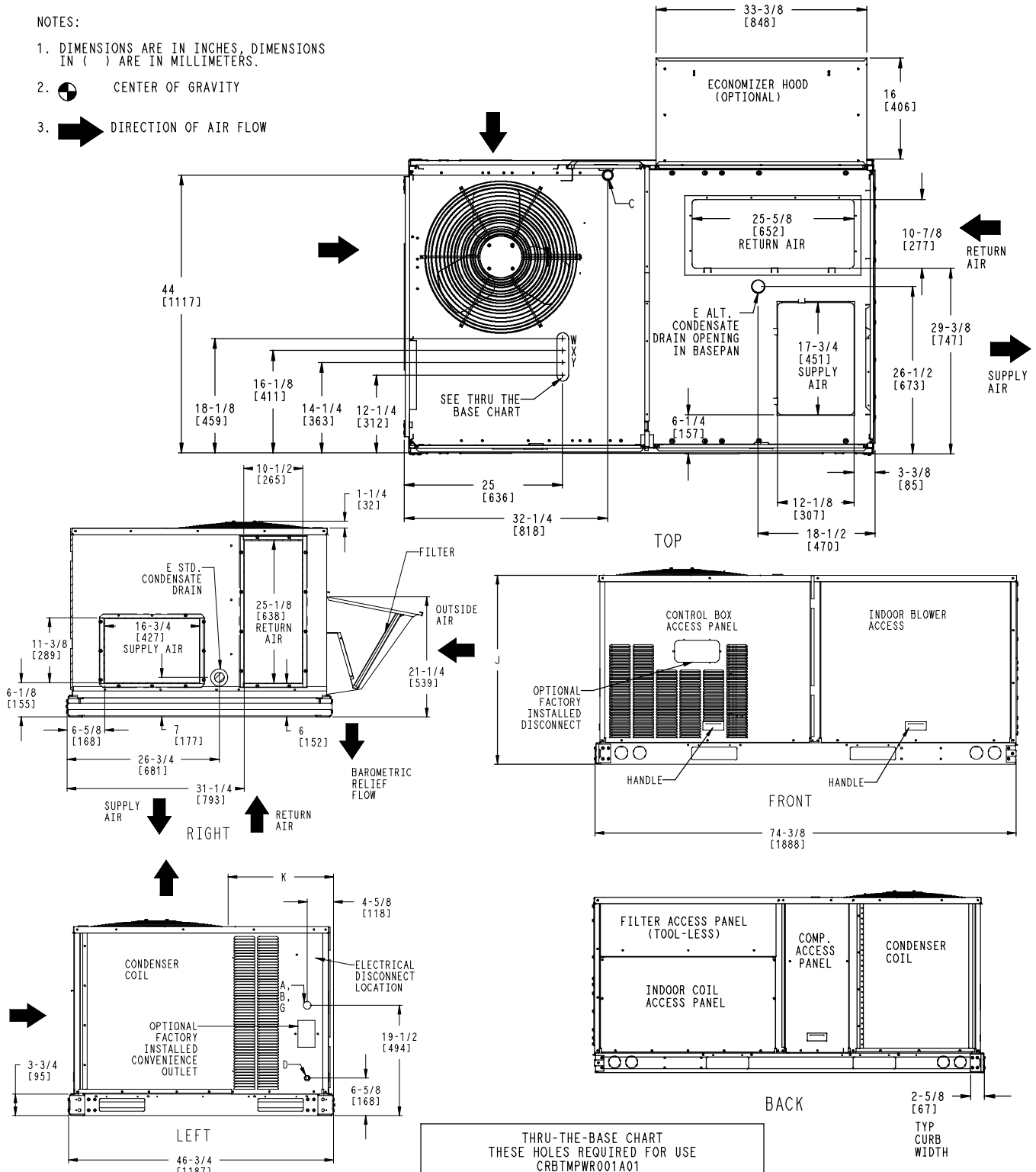

THRU-THE-BASE CHART THESE HOLES REQUIRED FOR USE CRBTMPWR001A01			
	THREADED CONDUIT SIZE	WIRE USE	REQ'D HOLE SIZES (MAX.)
	1/2"	ACC.	7/8" (22.2)
W	1/2"	24V	7/8" (22.2)
Y *	3/4" (001)	POWER	1 1/8" (28.4)
FOR "THRU-THE-BASEPAN" FACTORY OPTION, FITTINGS FOR ONLY X & Y ARE PROVIDED			
* SELECT EITHER 3/4" OR 1/2" FOR POWER, DEPENDING ON WIRE SIZE			

CONNECTION SIZES	
A	1 3/8" DIA [35] FIELD POWER SUPPLY HOLE
B	2" DIA [51] POWER SUPPLY KNOCKOUT
C	1 3/4" DIA [44] GAUGE ACCESS PLUG
D	7/8" DIA [22] FIELD CONTROL WIRING HOLE
E	3/4"-14 NPT CONDENSATE DRAIN
G	2 1/2" DIA [64] POWER SUPPLY KNOCK-OUT

UNIT	J	K
50TC-A04	33 3/8 [847]	18 5/8 [472]
50TC-A05	33 3/8 [847]	14 7/8 [377]
50TC-A06	33 3/8 [847]	14 7/8 [377]
50TC-A07	41 3/8 [1051]	14 7/8 [377]

Fig. 1 - Dimensions 50TC 04-07

CURBS, WEIGHTS & DIMENSIONS (cont.)

UNIT	STD. UNIT WEIGHT		CORNER WEIGHT (A)		CORNER WEIGHT (B)		CORNER WEIGHT (C)		CORNER WEIGHT (D)		C.G.		HEIGHT
	LBS.	KG.	LBS.	KG.	LBS.	KG.	LBS.	KG.	LBS.	KG.	X	Y	Z
50TC-A04	438	199	108	49	115	52	110	50	104	47	38 [965]	22 [559]	17 1/4 [438]
50TC-A05	494	224	122	55	130	59	125	57	117	53	38 [965]	22 [559]	17 1/2 [445]
50TC-A06	524	238	130	59	138	63	132	60	124	56	38 [965]	22 [559]	17 3/4 [451]
50TC-A07	607	275	150	68	160	73	153	69	144	65	38 [965]	22 [559]	20 3/4 [527]

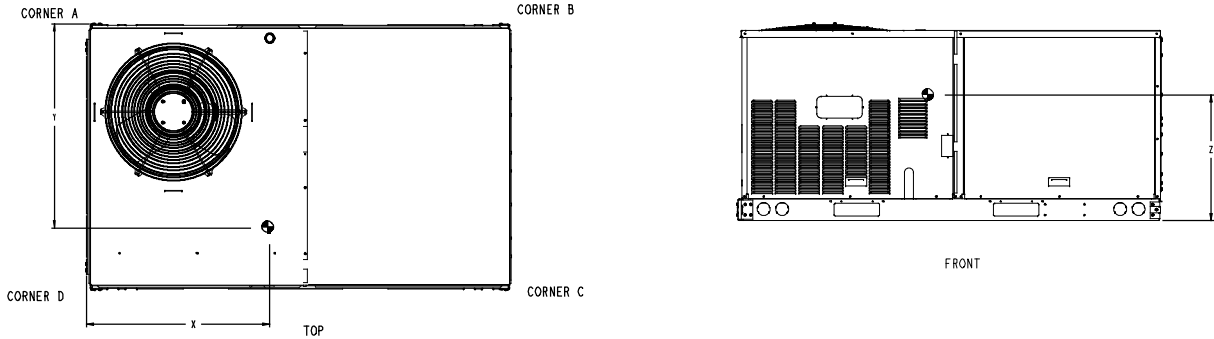

Fig. 2 - Dimensions 50TC 04-07

C08530

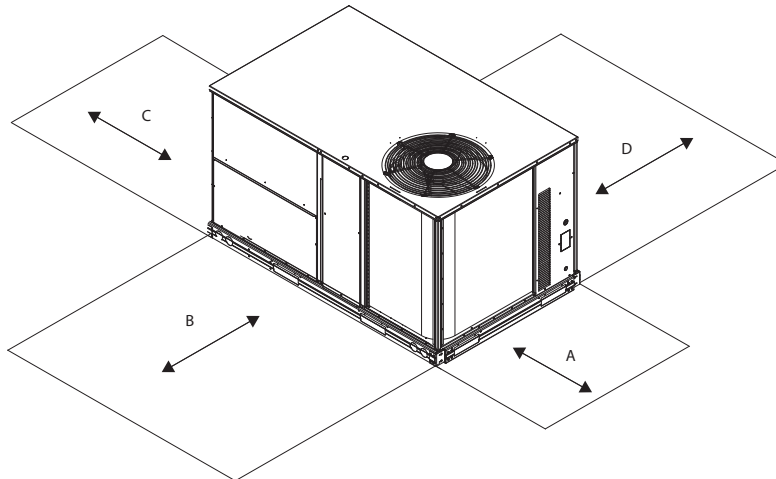

Fig. 3 - Service Clearance

C08337

LOC	DIMENSION	CONDITION
A	48-in (1219 mm)	Unit disconnect is mounted on panel
	18-in (457 mm)	No disconnect, convenience outlet option
	18-in (457 mm)	Recommended service clearance
	12-in (305 mm)	Minimum clearance
B	42-in (1067 mm)	Surface behind servicer is grounded (e.g., metal, masonry wall)
	36-in (914 mm)	Surface behind servicer is electrically non-conductive (e.g., wood, fiberglass)
	Special	Check for sources of flue products within 10-ft of unit fresh air intake hood
C	36-in (914 mm)	Side condensate drain is used
	18-in (457 mm)	Minimum clearance
D	42-in (1067 mm)	Surface behind servicer is grounded (e.g., metal, masonry wall, another unit)
	36-in (914 mm)	Surface behind servicer is electrically non-conductive (e.g., wood, fiberglass)

NOTE: Unit not designed to have overhead obstruction. Contact Application Engineering for guidance on any application planning overhead obstruction or vertical clearances.

CURBS, WEIGHTS & DIMENSIONS (cont.)

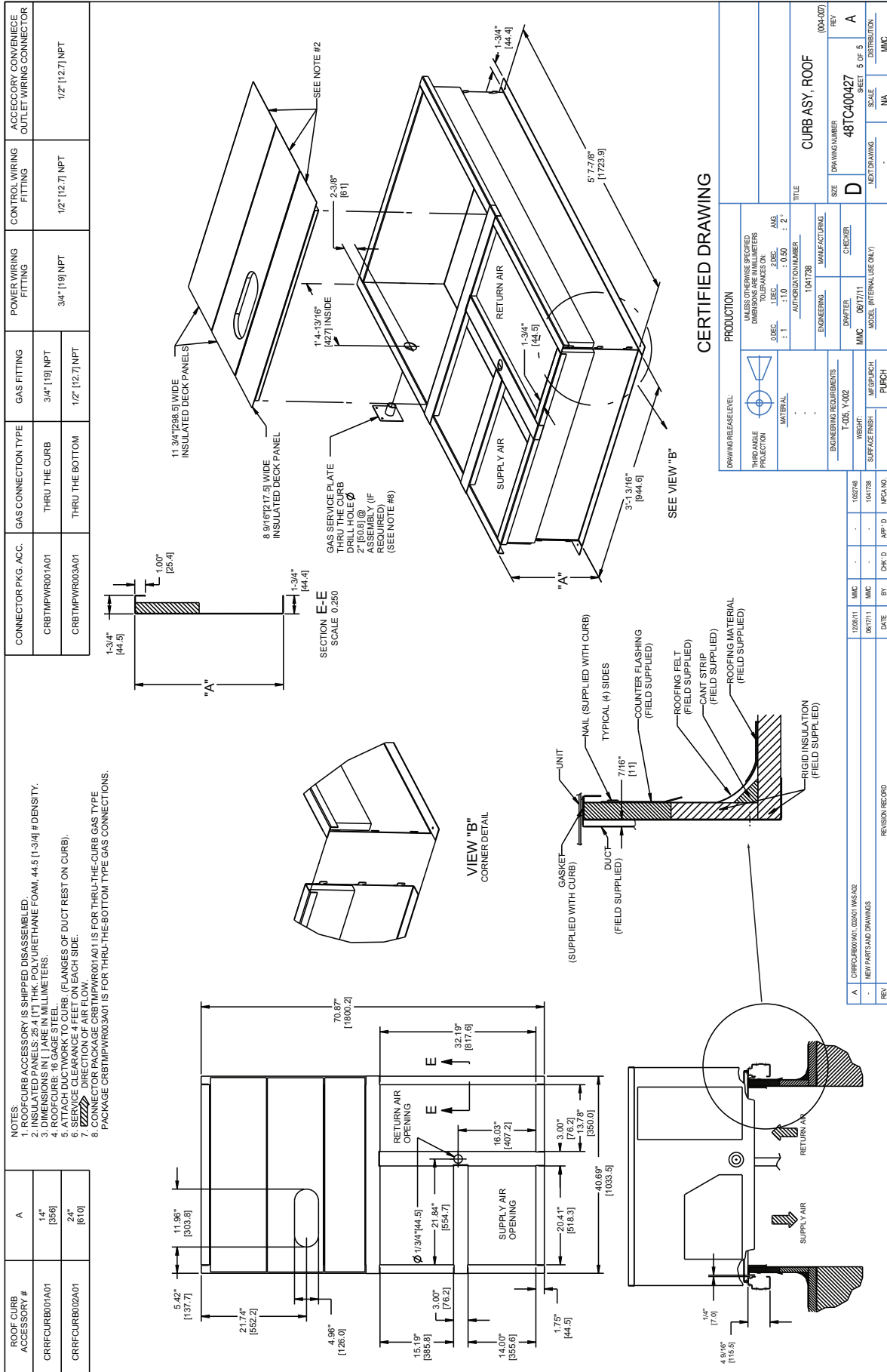

Fig. 4 - Roof Curb Details 50TC 04-07

CURBS, WEIGHTS & DIMENSIONS (cont.)

UNIT	OUTDOOR COIL TYPE	STD. UNIT WEIGHT ***		CORNER WEIGHT (A)		CORNER WEIGHT (B)		CORNER WEIGHT (C)		CORNER WEIGHT (D)		C.G.		
		LBS.	KG.	LBS.	KG.	LBS.	KG.	LBS.	KG.	LBS.	KG.	X	Y	Z
50TC-A08	RTPF	705	320	172	78	142	64.5	177	80.4	214	97.2	39 7/8 [1013]	33 [838]	21 1/4 [540]
50TC-A09	RTPF	845	383.6	206	93.5	167	76	212	96.2	261	118.5	39 1/2 [1003]	33 1/4 [845]	24 [610]
50TC-A12	RTPF	855	388	210	95.3	180	81.7	215	97.6	250	113.5	40 3/4 [1035]	32 3/8 [822]	25 1/4 [641]
50TC-D08	RTPF	760	345	158	71.7	155	70.4	222	100.8	225	102.2	43 3/4 [1111.3]	35 [889]	20 [508]
50TC-D09	RTPF	855	388.2	223	101.2	171	77.6	200	90.8	261	118.5	38 3/8 [975]	32 1/8 [816]	19 1/8 [486]
50TC-D12	RTPF	865	392.7	225	102.2	173	78.5	203	92.2	264	120	38 3/8 [975]	32 1/8 [816]	19 1/8 [486]
50TC-D08	MCHX	730	331.4	153	69.5	138	62.7	208	94.4	231	104.9	41 3/4 [1060.5]	35 3/4 [908]	21 1/8 [536.6]
50TC-D12	MCHX	820	372.3	179	81.3	161	73.1	228	103.5	253	114.9	41 3/4 [1060.5]	34 7/8 [885.8]	23 3/4 [603.3]

RTPF - ROUND TUBE, PLATE FIN (COPPER/ALUM)
MCHX - NOVAION (ALUM/ALUM)

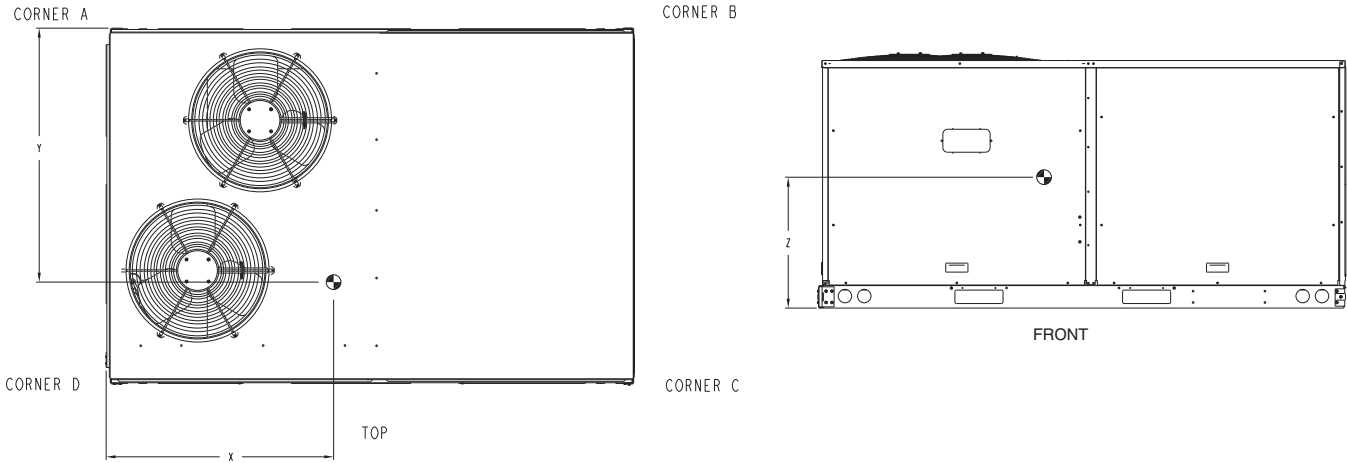

Fig. 6 - Dimensions 50TC 08-12

C101206

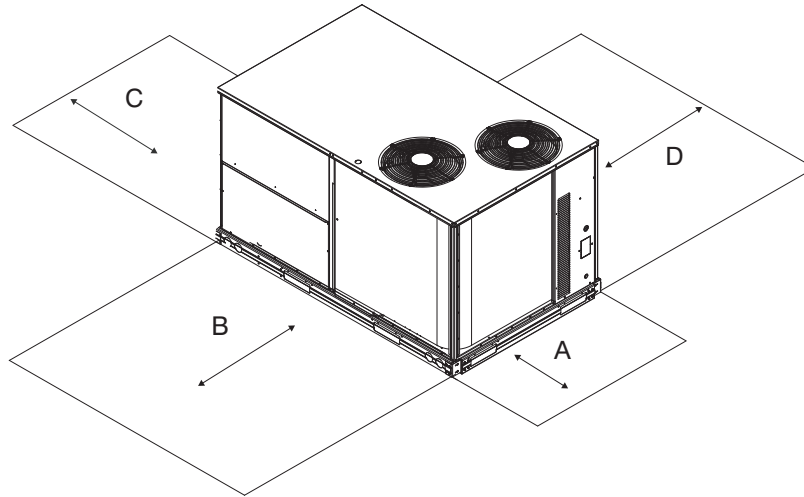

Fig. 7 - Service Clearance

C11247

LOC	DIMENSION	CONDITION
A	48-in (1219 mm)	Unit disconnect is mounted on panel
	36-in (914 mm)	If dimension - B is 12-in (305 mm)
	18-in (457 mm)	No disconnect, convenience outlet option
	18-in (457 mm)	Recommended service clearance (use electric screwdriver)
	12-in (305 mm)	Minimum clearance (use manual ratchet screwdriver)
B	36-in (914 mm)	Unit has economizer
	12-in (305 mm)	If dimension - A is 36-in (914 mm)
	Special	Check for sources of flue products within 10-ft of unit fresh air intake hood
C	36-in (914 mm)	Side condensate drain is used
	18-in (457 mm)	Minimum clearance
D	42-in (1067 mm)	Surface behind servicer is grounded (e.g., metal, masonry wall, another unit)
	36-in (914 mm)	Surface behind servicer is electrically non-conductive (e.g., wood, fiberglass)

NOTE: Unit not designed to have overhead obstruction. Contact Application Engineering for guidance on any application planning overhead obstruction or vertical clearances.

CURBS, WEIGHTS & DIMENSIONS (cont.)

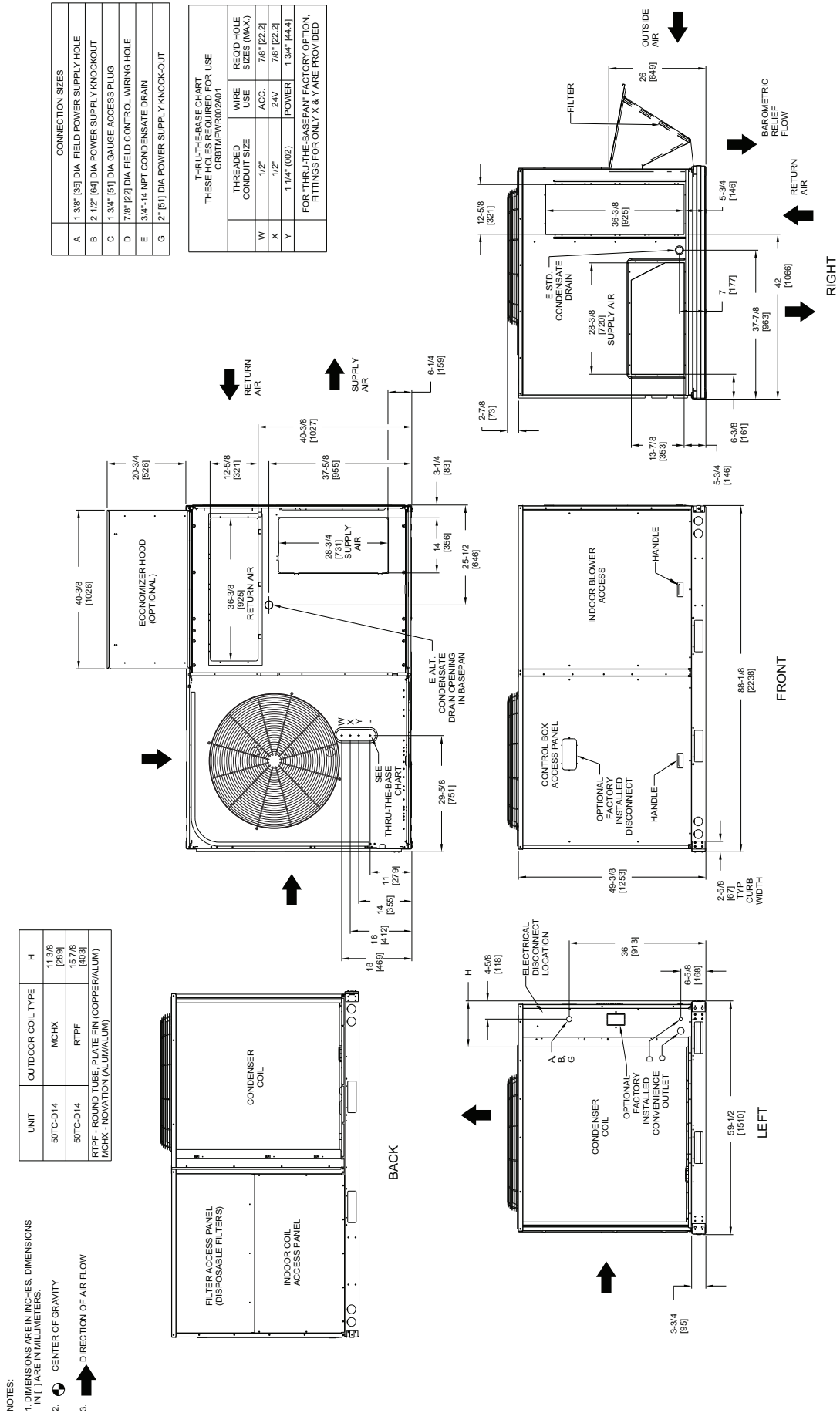

Fig. 8 - Dimensions 50TC-14

CURBS, WEIGHTS & DIMENSIONS (cont.)

UNIT	OUTDOOR COIL TYPE	STD. UNIT WEIGHT***		CORNER WEIGHT (A)		CORNER WEIGHT (B)		CORNER WEIGHT (C)		CORNER WEIGHT (D)		C.G.		
		LBS.	KG.	LBS.	KG.	LBS.	KG.	LBS.	KG.	LBS.	KG.	X	Y	Z
50TC-D14	MCHX	1030	467	294	133	146	66	197	89	395	179	28 3/8 [721]	33 1/8 [841]	21 3/8 [543]
50TC-D14	RTPF	1075	489	340	155	155	70	181	82	399	181	27 1/2 [699]	32 [813]	20 1/2 [523]

RTPF - ROUND TUBE, PLATE FIN (COPPER/ALUM)
MCHX - MICROCHANNEL (ALUM/ALUM)

*** STANDARD UNIT WEIGHT IS WITHOUT ELECTRIC HEAT AND WITHOUT PACKAGING.
FOR OTHER OPTIONS AND ACCESSORIES, REFER TO THE PRODUCT DATA CATALOG.

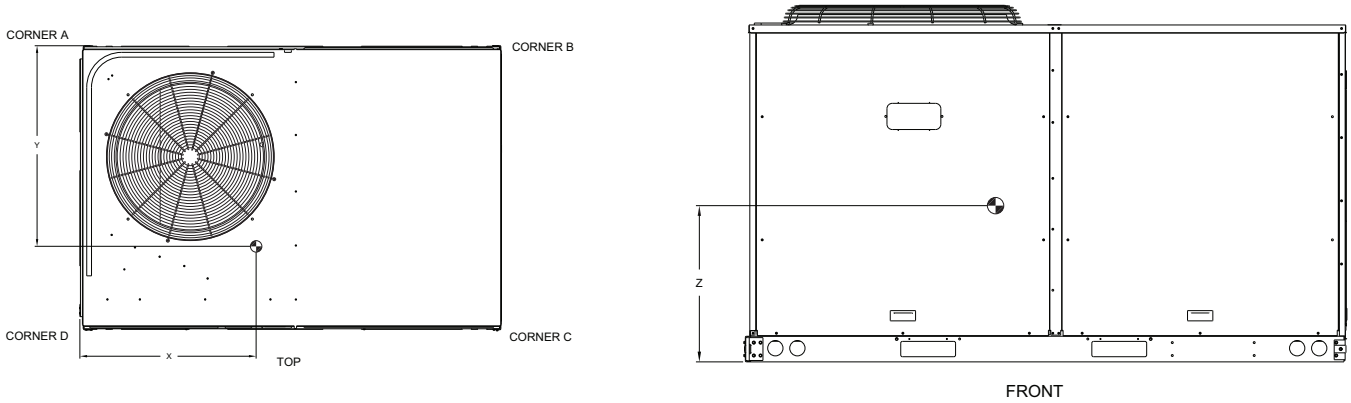

Fig. 9 - Dimensions 50TC-14

C101208

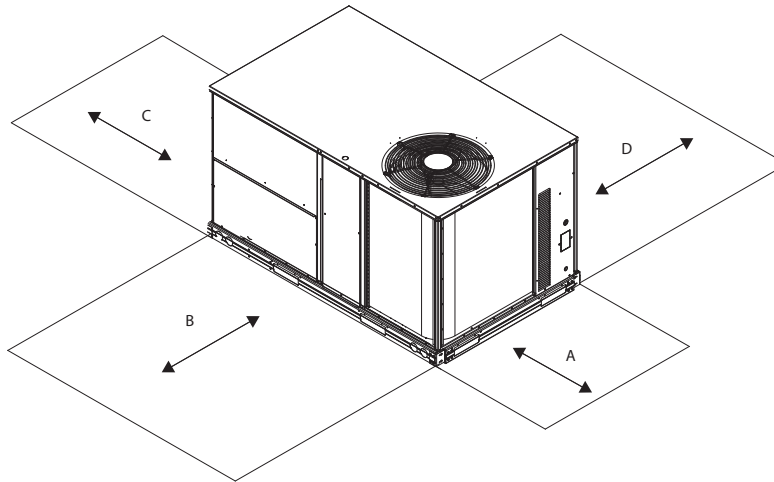

Fig. 10 - Service Clearance

C08337

LOC	DIMENSION	CONDITION
A	48-in (1219 mm)	Unit disconnect is mounted on panel
	18-in (457 mm)	No disconnect, convenience outlet option
	18-in (457 mm)	Recommended service clearance
	12-in (305 mm)	Minimum clearance
B	42-in (1067 mm)	Surface behind servicer is grounded (e.g., metal, masonry wall)
	36-in (914 mm)	Surface behind servicer is electrically non-conductive (e.g., wood, fiberglass)
	Special	Check for sources of flue products within 10-ft of unit fresh air intake hood
C	36-in (914 mm)	Side condensate drain is used
	18-in (457 mm)	Minimum clearance
D	42-in (1067 mm)	Surface behind servicer is grounded (e.g., metal, masonry wall, another unit)
	36-in (914 mm)	Surface behind servicer is electrically non-conductive (e.g., wood, fiberglass)

NOTE: Unit not designed to have overhead obstruction. Contact Application Engineering for guidance on any application planning overhead obstruction or vertical clearances.

CURBS, WEIGHTS & DIMENSIONS (cont.)

NOTES:

1. DIMENSIONS ARE IN INCHES. DIMENSIONS IN [] ARE IN MILLIMETERS.
2. CENTER OF GRAVITY
3. DIRECTION OF AIR FLOW

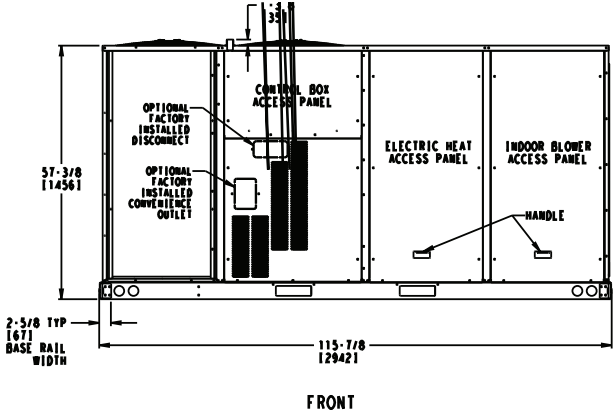
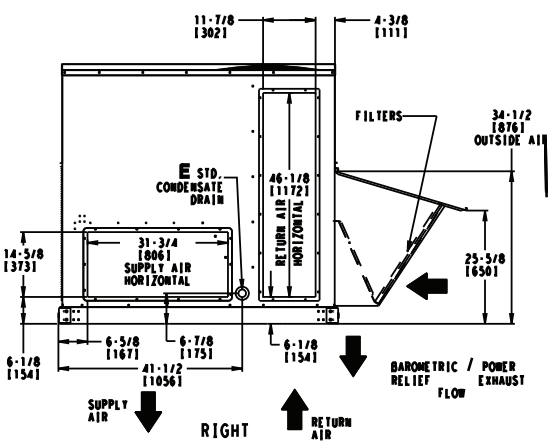
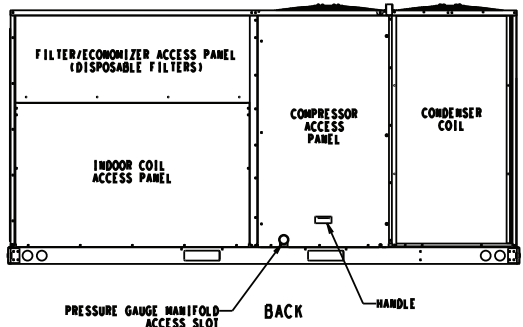
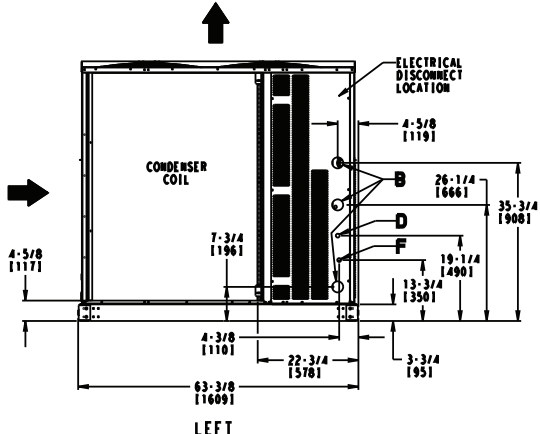
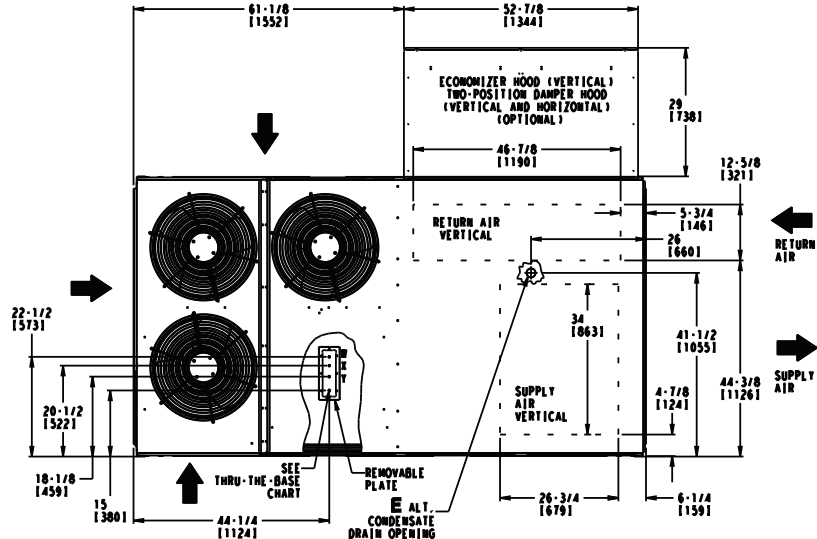

CONNECTION SIZES	
B	2 1/2" [64] DIA POWER SUPPLY HOLE
D	7/8" [22] DIA FIELD CONTROL WIRING HOLE
E	3/4"-14 NPT CONDENSATE DRAIN
F	7/8" [22] DIA FIELD CONVENIENCE OUTLET HOLE

THRU-THE-BASE CHART THESE HOLES REQUIRED FOR USE CRBTMPW005A00, 006A00, 007A00			
ACCESSORY NO.	THREADED CONDUIT SIZE	WIRE USE	REQ'D HOLE SIZES (MAX.)
005	W	1/2"	ACC. 7/8" [22.2]
	X	1/2"	24V 7/8" [22.2]
	Y	1 1/4"	POWER 1 1/2" [38.1]
006	W	1/2"	ACC. 7/8" [22.2]
	X	1/2"	24V 7/8" [22.2]
	Y	1 1/2"	POWER 2" [50.8]
007	W	1/2"	ACC. 7/8" [22.2]
	X	1/2"	24V 7/8" [22.2]
	Y	2"	POWER 2 1/2" [63.5]
FOR "THRU-THE-BASEPAN" FACTORY OPTION, FITTINGS FOR X & Y ARE PROVIDED AS SPECIFIED ON "006".			

Fig. 12 - Dimensions 50TC-16

CURBS, WEIGHTS & DIMENSIONS (cont.)

UNIT	STD UNIT WEIGHT		CORNER WEIGHT (A)		CORNER WEIGHT (B)		CORNER WEIGHT (C)		CORNER WEIGHT (D)		C.G.		
	LBS.	KG.	LBS.	KG.	LBS.	KG.	LBS.	KG.	LBS.	KG.	X	Y	Z
50TC 16	1305	593	268	122	325	148	389	177	322	146	58 1/2 [1486]	32 [813]	21 [533]

STANDARD UNIT WEIGHT IS WITHOUT ELECTRIC HEAT & WITHOUT PACKAGING.
FOR OPTIONS & ACCESSORIES, REFER TO THE PRODUCT DATA CATALOG.

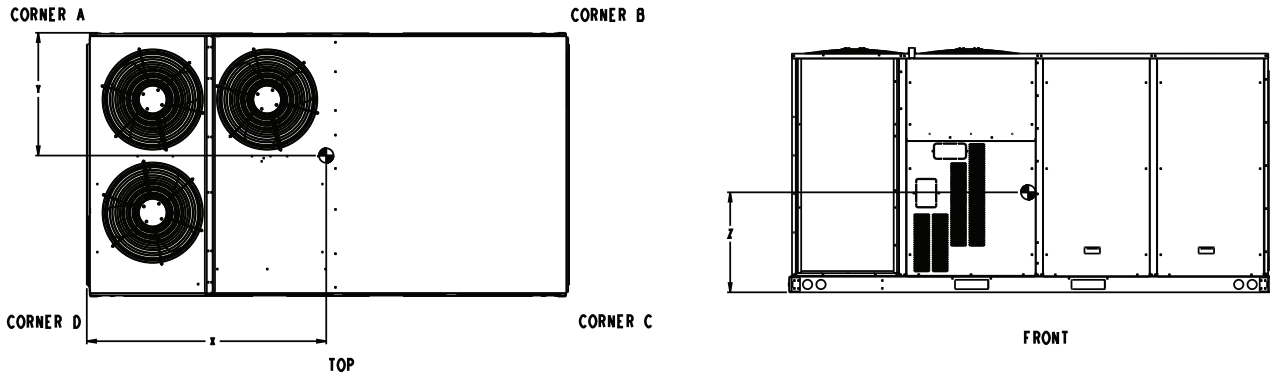

Fig. 13 - Dimensions 50TC-16

C101116A

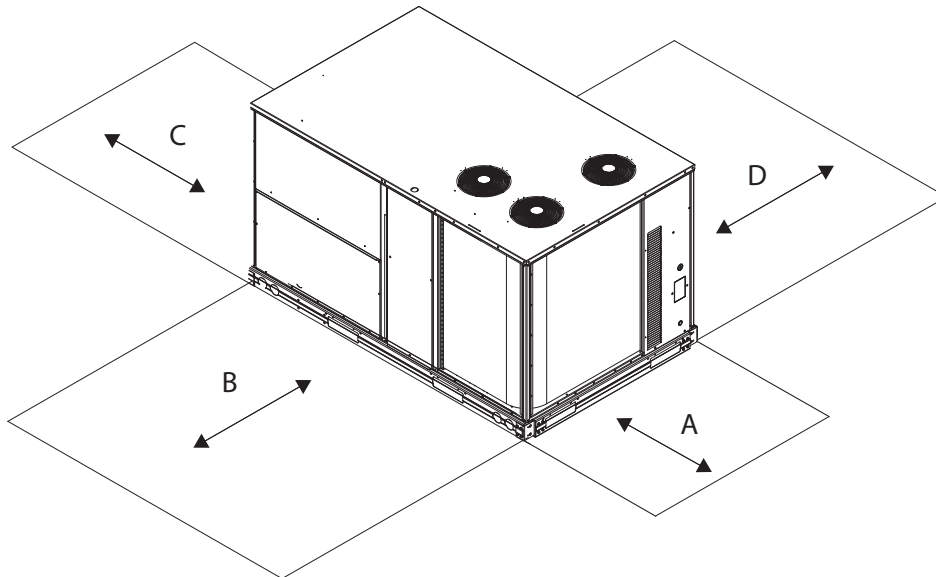

Fig. 14 - Service Clearance

C10578B

LOC	DIMENSION	CONDITION
A	48-in (1219 mm)	Unit disconnect is mounted on panel
	18-in (457 mm)	No disconnect, convenience outlet option
	18-in (457 mm)	Recommended service clearance
	12-in (305 mm)	Minimum clearance
B	42-in (1067 mm)	Surface behind servicer is grounded (e.g., metal, masonry wall)
	36-in (914 mm) Special	Surface behind servicer is electrically non-conductive (e.g., wood, fiberglass) Check for sources of flue products within 10-ft of unit fresh air intake hood
C	36-in (914 mm)	Side condensate drain is used
	18-in (457 mm)	Minimum clearance
D	48-in (1219 mm)	No flue discharge accessory installed, surface is combustible material
	42-in (1067 mm)	Surface behind servicer is grounded (e.g., metal, masonry wall, another unit)
	36-in (914 mm)	Surface behind servicer is electrically non-conductive (e.g., wood, fiberglass)
	Special	Check for adjacent units or building fresh air intakes within 10-ft of this unit's flue outlet

NOTE: Unit not designed to have overhead obstruction. Contact Application Engineering for guidance on any application planning overhead obstruction or vertical clearances.

CURBS, WEIGHTS & DIMENSIONS (cont.)

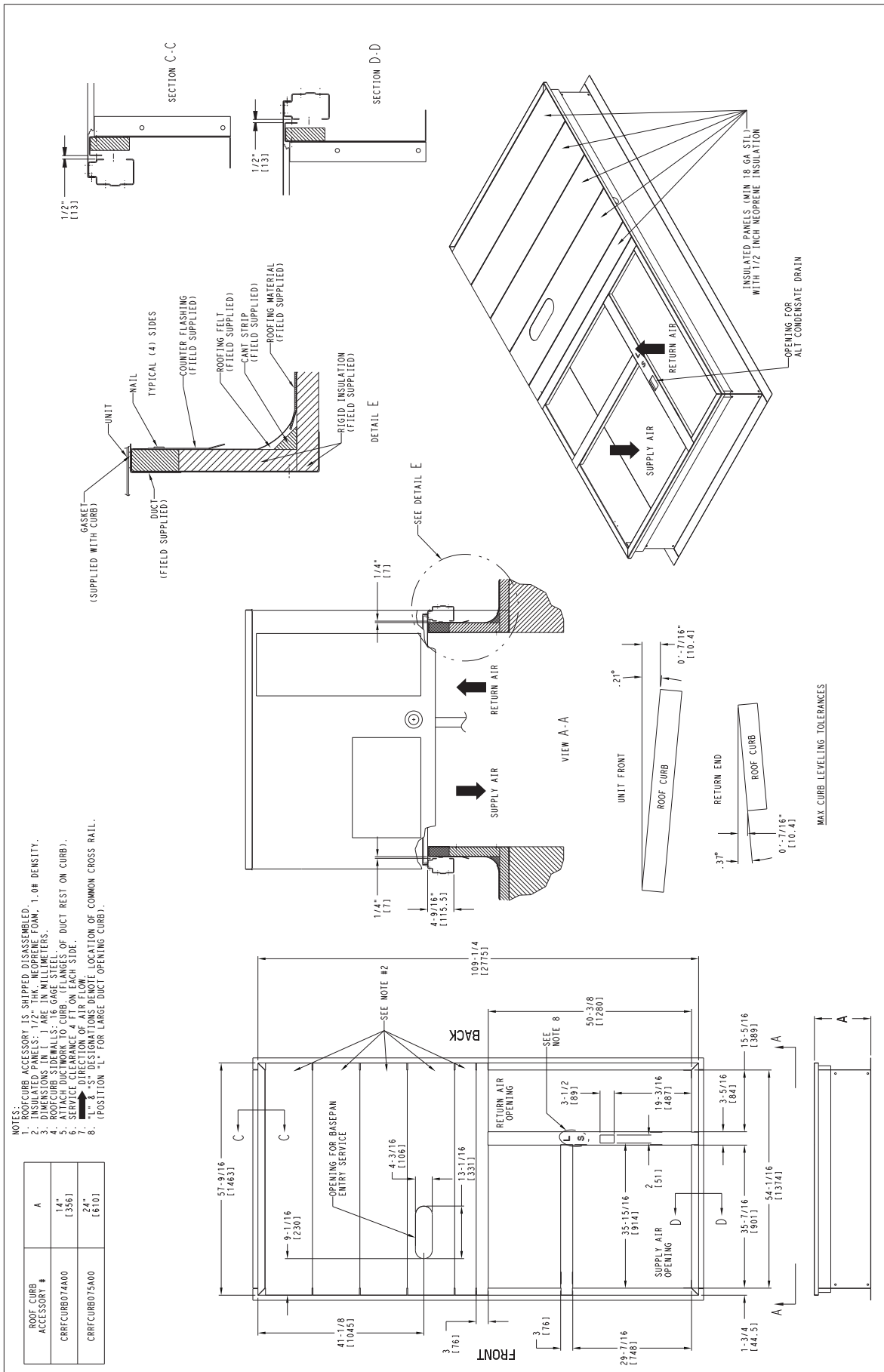

Fig. 15 - Roof Curb Details 50TC 16

OPTION / ACCESSORY WEIGHTS

OPTION / ACCESSORY	OPTION / ACCESSORY WEIGHTS																	
	04		05		06		07		08		09		12		14		16	
	lb	kg	lb	kg	lb	kg	lb	kg	lb	kg	lb	kg	lb	kg	lb	kg	lb	kg
Humidi–MiZer ¹	15	7	23	10	25	11	29	13	38	17	47	21	57	21	47	21	57	26
Power Exhaust – vertical	50	23	50	23	50	23	50	23	75	34	75	34	75	34	75	34	85	39
Power Exhaust – horizontal	30	14	30	14	30	14	30	14	30	14	30	14	30	14	30	14	75	34
EconoMi\$er (IV, X or 2)	50	23	50	23	50	23	50	23	75	34	75	34	75	34	75	34	115	52
Two Position damper	39	18	39	18	39	18	39	18	58	26	58	26	58	26	58	26	65	29
Manual Dampers	12	5	12	5	12	5	12	5	18	8	18	8	18	8	18	8	25	11
Hail Guard (louvered)	16	7	16	7	16	7	16	7	34	15	34	15	34	15	34	15	45	20
Cu/Cu Condenser Coil ²	6	3	13	6	13	6	15	7	12	5	23	10	23	10	23	10	190	86
Cu/Cu Cond. & Evaporator Coils ²	12	5	19	9	21	10	26	12	25	11	49	22	49	22	49	22	280	127
Roof Curb (14–in. curb)	115	52	115	52	115	52	115	52	143	65	143	65	143	65	143	65	180	82
Roof Curb (24–in. curb)	197	89	197	89	197	89	197	89	245	111	245	111	245	111	245	111	255	116
CO ₂ sensor	5	2	5	2	5	2	5	2	5	2	5	2	5	2	5	2	5	2
Electric Heater	30	14	30	14	30	14	30	14	45	20	45	20	45	20	45	20	25	11
Single Point Kit	10	5	10	5	10	5	10	5	12	5	12	5	12	5	15	7	25	11
Optional Indoor Motor / Drive	10	5	10	5	10	5	10	5	15	7	15	7	15	7	15	7	45	20
Motor Master Controller	35	16	35	16	35	16	35	16	35	16	35	16	35	16	40	18	35	16
Return Smoke Detector	5	2	5	2	5	2	5	2	5	2	5	2	5	2	5	2	5	2
Supply Smoke Detector	5	2	5	2	5	2	5	2	5	2	5	2	5	2	5	2	5	2
Non–Fused Disconnect	15	7	15	7	15	7	15	7	15	7	15	7	15	7	15	7	15	7
Powered Convenience outlet	35	16	35	16	35	16	35	16	35	16	35	16	35	16	35	16	35	16
Non–Powered Convenience outlet	5	2	5	2	5	2	5	2	5	2	5	2	5	2	5	2	5	2
Enthalpy Sensor	2	1	2	1	2	1	2	1	2	1	2	1	2	1	2	1	2	1
Differential Enthalpy Sensor	3	1	3	1	3	1	3	1	3	1	3	1	3	1	3	1	3	1
SAV System with VFD	–	–	–	–	–	–	–	–	20	9	20	9	20	9	20	9	20	9

NOTE: Where multiple variations are available, the heaviest combination is listed.

– Not Available

¹ For Humidi–MiZer add MotorMaster Controller.

² Where available.

APPLICATION DATA

Min operating ambient temp (cooling):

In mechanical cooling mode, your Carrier rooftop can safely operate down to an outdoor ambient temperature of 40°F (4°C) and 25°F (-4°C), with an accessory winter start kit. It is possible to provide cooling at lower outdoor ambient temperatures by using less outside air, economizers, and/or accessory low ambient kits.

Max operating ambient temp (cooling):

The maximum operating ambient temperature for cooling mode is 115°F (46°C). While cooling operation above 115°F (46°C) may be possible, it could cause either a reduction in performance, reliability, or a protective action by the unit's internal safety devices.

Min and max airflow (cooling mode):

To maintain safe and reliable operation of your rooftop, operate within the cooling airflow limits. Operating above the max may cause blow-off, undesired airflow noise, or airflow related problems with the rooftop unit. Operating below the min may cause problems with coil freeze-up.

Airflow:

All units are draw-through in cooling mode.

Outdoor air application strategies:

Economizers reduce operating expenses and compressor run time by providing a free source of cooling and a means of ventilation to match application changing needs. In fact, they should be considered for most applications. Also, consider the various economizer control methods and their benefits, as well as sensors required to accomplish your application goals. Please contact your local Carrier representative for assistance.

Motor limits, Brake horsepower (BHP):

Due to Carrier's internal unit design, air path, and specially designed motors, the full horsepower (maximum continuous BHP) band, as listed in the Physical Data tables, can be used with the utmost confidence. There is no need for extra safety factors, as Carrier's motors are designed and rigorously tested to use the entire, listed BHP range without either nuisance tripping or premature motor failure.

Sizing a rooftop

Bigger isn't necessarily better. While an air conditioner needs to have enough capacity to meet the load, it doesn't need excess capacity. In fact, having excess capacity typically results in very poor part load performance and humidity control.

Using higher design temperatures than ASHRAE recommends for your location, adding "safety factors" to the calculated load, and rounding up to the next largest unit, are all signs of oversizing air conditioners. Oversizing can cause short-cycling, and short cycling leads to poor humidity control, reduced efficiency, higher utility bills, drastic indoor temperature swings, excessive noise, and increased wear and tear on the air conditioner.

Rather than oversizing an air conditioner, wise contractors and engineers "right-size" or even slightly undersize air conditioners. Correctly sizing an air conditioner controls humidity better; promotes efficiency; reduces utility bills; extends equipment life, and maintains even, comfortable temperatures.

Low ambient applications

When equipped with a Carrier economizer, your rooftop unit can cool your space by bringing in fresh, cool outside air. In fact, when so equipped, accessory low ambient kit may not be necessary. In low ambient conditions, unless the outdoor air is excessively humid or contaminated, economizer-based "free cooling" is the preferred less costly and energy conscious method.

In low ambient applications where outside air might not be desired (such as contaminated or excessively humid outdoor environments), your Carrier rooftop can operate at ambient temperatures down to -20°F (-29°C) using the recommended accessory Motormaster low ambient controller.

Winter start

Carrier's winter start kit extends the low ambient limit of your rooftop to 25°F (-4°C). The kit bypasses the low pressure switch, preventing nuisance tripping of the low pressure switch. Other low ambient precautions may still be prudent.

APPLICATION DATA (cont.)

Staged Air Volume (SAV) with Variable Frequency Drive (VFD)

Carrier's Staged Air Volume (SAV) system utilizes a Variable Frequency Drive (VFD) to automatically adjust the indoor fan motor speed in sequence with the units cooling operation. Per ASHRAE 90.1 2010 standard section 6.4.3.10.b, during the first stage of cooling operation the VFD will adjust the fan motor to provide 2/3rd of the total cfm established for the unit. When a call for the second stage of cooling is required, the VFD will allow the total cfm for the unit established (100%). During the heating mode, the VFD will allow total design cfm (100%) operation and during the ventilation mode the VFD will allow operation to 2/3rd of total cfm.

The VFD used in Carrier's SAV system has soft start capabilities to slowly ramp up the speeds, thus eliminating any high inrush air volume during initial start-up. It also has internal over current protection for the fan motor and a field installed display kit that allows adjustment and in depth diagnostics of the VFD.

This SAV system is available on models with 2-stage cooling operation with electrical mechanical or RTU Open (multi Protocol) controls. Both space sensor and conventional thermostats/controls can be used to provide accurate control in any application.

The SAV system is very flexible for initial fan performance set up and adjustment. The standard factory shipped VFD is pre programmed to automatically stage the fan speed between the first and second stage of cooling. The unit fan performance static pressure and cfm can be easily adjusted using the traditional means of pulley adjustments. The other means to adjust the unit static and cfm performance is to utilize the field installed display module and adjust the frequency and voltage in the VFD to required performance requirements. In either case, once set up the VFD will automatically adjust the speed between the cooling stage operation.

SELECTION PROCEDURE (WITH 50TC*A07 EXAMPLE)

I. Determine cooling and heating loads.

Given:

Mixed Air Drybulb	80°F (27°C)
Mixed Air Wetbulb	67°F (19°C)
Ambient Drybulb	95°F (35°C)
TC _{Load}	69.0 MBH
SHC _{Load}	51.0 MBH
Vertical Supply Air	2100 CFM
External Static Pressure	0.66 in.wg
Electrical Characteristics	230-3-60

II. Make an initial guess at cooling tons.

$$\text{Refrig. tons} = \text{TC}_{\text{Load}} / 12 \text{ MBH per ton}$$

$$\text{Refrig. tons} = 69.0 / 12 = 5.75 \text{ tons}$$

In this case, start by looking at the 50TC*A07.

III. Look up the rooftop's TC and SHC.

Table 6 shows that, at the application's supply air CFM, mixed air and ambient temperatures, the 50TC*A07 supplies:

$$\text{TC}_{\text{Load}} = 73.7 \text{ MBH}$$

$$\text{SHC}_{\text{Load}} = 54.4 \text{ MBH.}$$

IV. Calculate the building Latent Heat Load.

$$\text{LC}_{\text{Load}} = \text{TC}_{\text{Load}} - \text{SHC}_{\text{Load}}$$

$$\text{LC}_{\text{Load}} = 69.0 \text{ MBH} - 51.0 \text{ MBH} = 18.0 \text{ MBH}$$

V. Calculate RTU Latent Heat Capacity

$$\text{LC} = \text{TC} - \text{SHC}$$

$$\text{LC} = 73.7 \text{ MBH} - 54.4 \text{ MBH} = 19.3 \text{ MBH}$$

VI. Compare RTU capacities to loads. ^{2,3}

Compare the rooftop's SHC and LC to the building's Sensible and Latent Heat Loads.

VII. Select factory options (FIOP)

Local code requires an economizer for any unit with TC larger than 65.0 MBH.

VIII. Calculate the total static pressure.

External static pressure	0.66 in. wg
Sum of FIOP/Accessory static	<u>+0.14 in. wg</u>
Total Static Pressure	0.80 in. wg

IX. Look up the Indoor Fan RPM & BHP.

Table 8 shows, at 2100 CFM & ESP= 0.8, RPM = 1268 & BHP = 1.52

X. Determine electrical requirements

The MCA and MOCP tables show a 50TC*A07 (without convenience outlet) as:

$$\text{MCA} = 30.5 \text{ amps} \ \& \ \text{MOCP} = 45 \text{ amps}$$

$$\text{Min. Disconnect Size: FLA} = 30 \ \& \ \text{LRA} = 157.$$

Legend:

BHP	—	Brake horsepower
FLA	—	Full load amps
LC	—	Latent capacity
LRA	—	Lock rotor amp
MBH	—	(1,000) BTUH
MCA	—	Min. circuit ampacity
MOCP	—	Max. over-current protection
RPM	—	Revolutions per minute
RTU	—	Rooftop unit
SHC	—	Sensible heat capacity
TC	—	Total capacity

NOTES:

1. Selection software by Carrier saves time by performing many of the steps above. Contact your Carrier sales representative for assistance.
2. Selecting a unit with a SHC slightly lower than the SHC_{Load} is often better than oversizing. Slightly lower SHC's will help control indoor humidity, and prevent temperature swings.
3. If the rooftop's capacity meets the Sensible Heat Load, but not the Latent Heat Load.
4. Indoor Fan Motor efficiency is available in Table 10. Use the decimal form in the equation eg. 80% = .8.

Table 6 – COOLING CAPACITIES

1-STAGE COOLING

3 TONS

50TC*A04 (RTPF)				AMBIENT TEMPERATURE											
				85			95			105			115		
				EAT (db)			EAT (db)			EAT (db)			EAT (db)		
		75	80	85	75	80	85	75	80	85	75	80	85		
900 Cfm	EAT (wb)	58	TC	28.1	28.1	31.7	26.3	26.3	29.8	24.5	24.5	27.7	22.6	22.6	25.5
			SHC	24.4	28.1	31.7	22.9	26.3	29.8	21.3	24.5	27.7	19.6	22.6	25.5
		62	TC	30.3	30.3	31.0	27.8	27.8	29.8	25.1	25.1	28.4	22.6	22.6	26.5
			SHC	22.6	26.8	31.0	21.5	25.7	29.8	20.2	24.3	28.4	18.7	22.6	26.5
		67	TC	35.5	35.5	35.5	33.1	33.1	33.1	30.5	30.5	30.5	27.5	27.5	27.5
	SHC		19.5	23.7	27.9	18.5	22.7	26.9	17.4	21.6	25.8	16.2	20.4	24.6	
	72	TC	39.0	39.0	39.0	37.1	37.1	37.1	35.1	35.1	35.1	32.7	32.7	32.7	
		SHC	15.3	19.5	23.7	14.5	18.8	23.0	13.7	17.9	22.2	12.9	17.1	21.3	
	76	TC	-	41.4	41.4	-	39.6	39.6	-	37.6	37.6	-	35.4	35.4	
		SHC	-	16.0	21.0	-	15.4	20.2	-	14.6	19.3	-	13.8	18.3	
1050 Cfm	EAT (wb)	58	TC	30.2	30.2	34.2	28.4	28.4	32.2	26.5	26.5	30.0	24.5	24.5	27.7
			SHC	26.3	30.2	34.2	24.7	28.4	32.2	23.1	26.5	30.0	21.3	24.5	27.7
		62	TC	31.9	31.9	34.2	29.4	29.4	32.8	26.7	26.7	31.2	24.5	24.5	28.8
			SHC	24.6	29.4	34.2	23.4	28.1	32.8	22.0	26.6	31.2	20.3	24.5	28.8
		67	TC	36.7	36.7	36.7	34.8	34.8	34.8	32.2	32.2	32.2	29.1	29.1	29.1
	SHC		20.6	25.4	30.2	19.8	24.6	29.4	18.8	23.6	28.4	17.6	22.4	27.2	
	72	TC	40.1	40.1	40.1	38.2	38.2	38.2	36.1	36.1	36.1	33.7	33.7	33.7	
		SHC	15.7	20.5	25.3	15.0	19.8	24.6	14.2	19.0	23.8	13.4	18.2	23.0	
	76	TC	-	42.4	42.4	-	40.6	40.6	-	38.5	38.5	-	36.2	36.2	
		SHC	-	16.6	22.2	-	15.9	21.3	-	15.2	20.4	-	14.4	19.5	
1200 Cfm	EAT (wb)	58	TC	32.2	32.2	36.4	30.4	30.4	34.3	28.4	28.4	32.1	26.3	26.3	29.7
			SHC	28.0	32.2	36.4	26.4	30.4	34.3	24.7	28.4	32.1	22.8	26.3	29.7
		62	TC	33.3	33.3	37.0	30.8	30.8	35.5	28.4	28.4	33.4	26.3	26.3	30.9
			SHC	26.4	31.7	37.0	25.1	30.3	35.5	23.4	28.4	33.4	21.7	26.3	30.9
		67	TC	37.7	37.7	37.7	35.6	35.6	35.6	33.4	33.4	33.4	30.4	30.4	30.4
	SHC		21.7	27.0	32.4	20.9	26.3	31.6	20.0	25.4	30.8	18.8	24.2	29.6	
	72	TC	40.9	40.9	40.9	39.0	39.0	39.0	36.9	36.9	36.9	34.4	34.4	34.4	
		SHC	16.1	21.5	26.8	15.4	20.8	26.1	14.7	20.0	25.4	13.8	19.2	24.5	
	76	TC	-	43.1	43.1	-	41.3	41.3	-	39.1	39.1	-	36.8	36.8	
		SHC	-	17.1	23.1	-	16.4	22.3	-	15.7	21.4	-	14.9	20.5	
1350 Cfm	EAT (wb)	58	TC	-	-	-	32.1	32.1	36.3	30.0	30.0	34.0	27.9	27.9	31.5
			SHC	-	-	-	27.9	32.1	36.3	26.1	30.0	34.0	24.2	27.9	31.5
		62	TC	28.4	28.4	30.5	32.2	32.2	37.8	30.1	30.1	35.3	27.9	27.9	32.8
			SHC	17.6	24.1	30.5	26.6	32.2	37.8	24.8	30.1	35.3	23.0	27.9	32.8
		67	TC	33.2	33.2	33.2	36.4	36.4	36.4	34.1	34.1	34.1	31.5	31.5	32.0
	SHC		15.0	21.4	27.9	21.9	27.8	33.7	21.0	26.9	32.9	20.0	26.0	32.0	
	72	TC	37.5	37.5	37.5	39.7	39.7	39.7	37.5	37.5	37.5	35.0	35.0	35.0	
		SHC	11.8	18.3	24.8	15.8	21.7	27.5	15.0	20.9	26.8	14.2	20.1	26.0	
	76	TC	-	40.1	40.1	-	41.8	41.8	-	39.6	39.6	-	37.3	37.3	
		SHC	-	15.3	22.7	-	16.8	23.2	-	16.1	22.3	-	15.3	21.5	
1500 Cfm	EAT (wb)	58	TC	28.1	28.1	34.2	33.7	33.7	38.1	31.6	31.6	35.7	29.3	29.3	33.2
			SHC	21.9	28.1	34.2	29.3	33.7	38.1	27.4	31.6	35.7	25.5	29.3	33.2
		62	TC	30.3	30.3	33.8	33.7	33.7	39.6	31.6	31.6	37.1	29.4	29.4	34.5
			SHC	19.8	26.8	33.8	27.8	33.7	39.6	26.1	31.6	37.1	24.2	29.4	34.5
		67	TC	35.5	35.5	35.5	36.9	36.9	36.9	34.6	34.6	34.9	32.0	32.0	34.0
	SHC		16.7	23.7	30.7	22.8	29.2	35.7	21.9	28.4	34.9	21.0	27.5	34.0	
	72	TC	39.0	39.0	39.0	40.2	40.2	40.2	38.0	38.0	38.0	35.5	35.5	35.5	
		SHC	12.4	19.5	26.6	16.1	22.5	28.8	15.4	21.7	28.1	14.6	21.0	27.4	
	76	TC	-	41.4	41.4	-	42.2	42.2	-	40.0	40.0	-	-	-	
		SHC	-	16.0	24.3	-	17.2	24.0	-	16.5	23.2	-	-	-	

LEGEND:

- Do not operate
- Cfm - Cubic feet per minute (supply air)
- EAT(db) - Entering air temperature (dry bulb)
- EAT(wb) - Entering air temperature (wet bulb)
- SHC - Sensible heat capacity
- TC - Total capacity

50TC04 (3 TONS) – UNIT WITH HUMIDI-MIZER SYSTEM IN SUBCOOLING MODE										
Air Entering Evaporator – CFM										
Temp (F) Air Ent Condenser (Edb)		80 dry bulb			80 dry bulb			80 dry bulb		
		72 wet bulb			67 wet bulb			62 wet bulb		
		900	1200	1500	900	1200	1500	900	1200	1500
75	TC	40.6	43.2	45.3	37.0	39.4	41.3	33.4	35.6	37.4
	SHC	21.6	23.9	25.6	25.6	27.7	29.3	29.6	31.6	33.1
	kW	2.0	2.0	2.0	2.0	2.0	2.0	2.0	2.0	2.0
85	TC	37.0	39.6	41.7	33.6	36.0	37.9	30.2	32.3	34.1
	SHC	17.7	20.2	22.2	22.7	25.0	26.9	27.7	29.9	31.6
	kW	2.3	2.3	2.3	2.3	2.3	2.3	2.3	2.3	2.3
95	TC	33.5	36.0	38.1	30.2	32.5	34.4	26.9	29.1	30.8
	SHC	13.7	16.6	18.8	19.7	22.4	24.4	25.7	28.2	30.1
	kW	2.6	2.6	2.6	2.5	2.5	2.5	2.5	2.5	2.5
105	TC	29.9	32.4	34.5	26.8	29.1	31.0	23.6	25.8	27.5
	SHC	9.8	12.9	15.3	16.8	19.7	22.0	23.8	26.5	28.6
	kW	2.9	2.9	2.9	2.8	2.8	2.8	2.8	2.8	2.8
115	TC	26.3	28.8	30.9	23.3	25.7	27.5	20.4	22.5	24.2
	SHC	5.8	9.2	11.9	13.8	17.0	19.5	21.9	24.8	27.1
	kW	3.2	3.2	3.2	3.1	3.1	3.1	3.1	3.1	3.1

50TC04 (3 TONS) – UNIT WITH HUMIDI-MIZER SYSTEM IN HOT GAS REHEAT MODE										
Air Entering Evaporator – CFM										
Temp (F) Air Ent Condenser (Edb)		75 dry bulb			75 dry bulb			75 dry bulb		
		62.5 wet bulb (50% relative)			64 wet bulb (55% relative)			65.3 wet bulb (60% relative)		
		1050	1200	1350	1050	1200	1350	1050	1200	1350
80	TC	14.7	15.5	16.2	15.9	16.7	17.4	16.9	17.7	18.4
	SHC	6.7	7.6	8.5	4.8	5.7	6.6	3.2	4.1	5.0
	kW	2.0	2.0	2.0	2.0	2.0	2.0	2.0	2.0	2.0
75	TC	15.1	15.8	16.4	16.2	17.0	17.6	17.2	18.0	18.6
	SHC	7.5	8.4	9.2	5.8	6.7	7.5	4.4	5.2	6.0
	kW	1.9	1.9	1.9	2.0	2.0	2.0	2.0	2.0	2.0
70	TC	15.5	16.1	16.7	16.6	17.3	17.9	17.5	18.2	18.8
	SHC	8.4	9.3	10.0	6.9	7.7	8.5	5.5	6.4	7.1
	kW	1.9	1.9	1.9	1.9	1.9	1.9	1.9	1.9	1.9
60	TC	16.2	16.8	17.3	17.2	17.8	18.3	18.1	18.7	19.2
	SHC	10.2	10.9	11.6	8.9	9.7	10.4	7.8	8.6	9.3
	kW	1.8	1.8	1.8	1.8	1.8	1.8	1.9	1.9	1.9
50	TC	17.0	17.5	17.9	17.9	18.4	18.8	18.7	19.2	19.6
	SHC	11.9	12.6	13.2	11.0	11.6	12.2	10.1	10.8	11.4
	kW	1.7	1.7	1.7	1.8	1.8	1.8	1.8	1.8	1.8
40	TC	17.7	18.1	18.5	18.6	19.0	19.3	19.3	19.7	20.1
	SHC	13.7	14.3	14.8	13.0	13.6	14.1	12.4	13.0	13.5
	kW	1.7	1.7	1.7	1.7	1.7	1.7	1.7	1.7	1.7

LEGEND

- Edb** – Entering Dry–Bulb
- Ewb** – Entering Wet–Bulb
- kW** – Compressor Motor Power Input
- ldb** – Leaving Dry–Bulb
- lwb** – Leaving Wet–Bulb
- SHC** – Sensible Heat Capacity (1000 Btuh) Gross
- TC** – Total Capacity (1000 Btuh) Gross

NOTES:

1. Direct interpolation is permissible. Do not extrapolate.
2. The following formulas may be used:

$$t_{ldb} = t_{edb} - \frac{\text{sensible capacity (Btuh)}}{1.10 \times \text{cfm}}$$

t_{lwb} = Wet–bulb temperature corresponding to enthalpy of air leaving evaporator coil (h_{lwb})

$$h_{lwb} = h_{ewb} - \frac{\text{total capacity (Btuh)}}{4.5 \times \text{cfm}}$$

Where: h_{ewb} = Enthalpy of air entering evaporator coil

Table 6 - COOLING CAPACITIES (cont.)

1-STAGE COOLING

4 TONS

50TC*A05 (RTPF)			AMBIENT TEMPERATURE												
			85			95			105			115			
			EAT (db)			EAT (db)			EAT (db)			EAT (db)			
			75	80	85	75	80	85	75	80	85	75	80	85	
1200 Cfm	EAT (wb)	58	TC	-	-	-	-	-	-	36.1	36.1	40.7	34.3	34.3	38.6
		58	SHC	-	-	-	-	-	-	31.5	36.1	40.7	29.9	34.3	38.6
		62	TC	43.1	43.1	43.1	40.8	40.8	40.8	38.4	38.4	39.4	35.9	35.9	38.2
		62	SHC	31.2	36.4	41.7	30.1	35.3	40.6	28.9	34.1	39.4	27.8	33.0	38.2
		67	TC	47.4	47.4	47.4	45.2	45.2	45.2	42.9	42.9	42.9	40.3	40.3	40.3
	72	TC	51.1	51.1	51.1	49.1	49.1	49.1	46.8	46.8	46.8	43.9	43.9	43.9	
	72	SHC	20.1	25.5	30.9	19.4	24.7	30.1	18.4	23.7	29.0	17.4	22.7	28.0	
	76	TC	-	53.3	53.3	-	51.5	51.5	-	49.2	49.2	-	45.9	45.9	
	76	SHC	-	20.8	27.4	-	20.2	26.8	-	19.3	25.7	-	18.3	24.6	
	1400 cfm	EAT (wb)	58	TC	41.9	41.9	47.3	40.1	40.1	45.3	38.2	38.2	43.2	36.3	36.3
58			SHC	36.6	41.9	47.3	35.0	40.1	45.3	33.3	38.2	43.2	31.7	36.3	41.0
62			TC	44.6	44.6	45.4	42.3	42.3	44.2	39.8	39.8	42.9	37.3	37.3	41.6
62			SHC	33.4	39.4	45.4	32.3	38.3	44.2	31.0	37.0	42.9	29.8	35.7	41.6
67			TC	48.7	48.7	48.7	46.6	46.6	46.6	44.2	44.2	44.2	41.4	41.4	41.4
72		TC	52.2	52.2	52.2	50.3	50.3	50.3	47.8	47.8	47.8	44.8	44.8	44.8	
72		SHC	20.6	26.7	32.7	19.9	25.9	32.0	18.9	24.9	30.9	17.9	23.8	29.7	
76		TC	-	54.1	54.1	-	52.3	52.3	-	49.9	49.9	-	46.4	46.4	
76		SHC	-	21.5	29.0	-	20.8	28.0	-	19.9	26.9	-	18.8	25.7	
1600 Cfm		EAT (wb)	58	TC	44.0	44.0	49.6	42.1	42.1	47.4	40.1	40.1	45.2	38.1	38.1
	58		SHC	38.3	44.0	49.6	36.7	42.1	47.4	34.9	40.1	45.2	33.2	38.1	43.0
	62		TC	45.7	45.7	48.6	43.5	43.5	47.5	41.0	41.0	46.0	38.5	38.5	44.4
	62		SHC	35.3	42.0	48.6	34.2	40.8	47.5	32.9	39.4	46.0	31.6	38.0	44.4
	67		TC	49.8	49.8	49.8	47.6	47.6	47.6	45.1	45.1	45.1	42.3	42.3	42.3
	72	TC	53.0	53.0	53.0	51.1	51.1	51.1	48.6	48.6	48.6	45.4	45.4	45.4	
	72	SHC	21.0	27.6	34.3	20.3	27.0	33.6	19.4	26.0	32.6	18.3	24.8	31.3	
	76	TC	-	54.6	54.6	-	52.8	52.8	-	50.4	50.4	-	46.8	46.8	
	76	SHC	-	22.0	29.9	-	21.3	29.0	-	20.3	27.9	-	19.2	26.6	
	1800 Cfm	EAT (wb)	58	TC	44.0	44.0	50.3	42.1	42.1	48.1	40.1	40.1	45.9	38.0	38.0
58			SHC	37.6	44.0	50.3	36.0	42.1	48.1	34.3	40.1	45.9	32.6	38.0	43.5
62			TC	45.7	45.7	49.5	43.5	43.5	48.3	41.0	41.0	46.8	38.4	38.4	45.2
62			SHC	34.5	42.0	49.5	33.4	40.8	48.3	32.1	39.4	46.8	30.8	38.0	45.2
67			TC	49.8	49.8	49.8	47.6	47.6	47.6	45.1	45.1	45.1	42.3	42.3	42.3
72		TC	53.0	53.0	53.0	51.1	51.1	51.1	48.6	48.6	48.6	45.4	45.4	45.4	
72		SHC	20.2	27.6	35.1	19.5	27.0	34.4	18.5	26.0	33.4	17.5	24.8	32.1	
76		TC	-	54.6	54.6	-	52.8	52.8	-	50.4	50.4	-	46.8	46.8	
76		SHC	-	22.0	30.9	-	21.3	30.0	-	20.3	28.9	-	19.2	27.5	
2000 Cfm		EAT (wb)	58	TC	46.9	46.9	52.9	45.0	45.0	50.8	42.9	42.9	48.4	40.7	40.7
	58		SHC	40.9	46.9	52.9	39.3	45.0	50.8	37.4	42.9	48.4	35.5	40.7	45.9
	62		TC	47.5	47.5	54.0	45.3	45.3	52.5	43.0	43.0	50.3	40.7	40.7	47.7
	62		SHC	38.5	46.3	54.0	37.3	44.9	52.5	35.6	43.0	50.3	33.8	40.7	47.7
	67		TC	51.2	51.2	51.2	49.1	49.1	49.1	46.5	46.5	46.5	43.5	43.5	43.5
	72	TC	54.0	54.0	54.0	52.1	52.1	52.1	49.7	49.7	49.7	46.2	46.2	46.2	
	72	SHC	21.7	29.2	36.8	21.1	28.7	36.4	20.1	27.8	35.4	18.9	26.4	33.9	
	76	TC	-	55.2	55.2	-	53.5	53.5	-	51.0	51.0	-	47.3	47.3	
	76	SHC	-	22.7	31.4	-	22.0	30.6	-	21.1	29.6	-	19.9	28.1	

LEGEND:

- Do not operate
- Cfm - Cubic feet per minute (supply air)
- EAT(db) - Entering air temperature (dry bulb)
- EAT(wb) - Entering air temperature (wet bulb)
- SHC - Sensible heat capacity
- TC - Total capacity

50TC05 (4 TONS) – UNIT WITH HUMIDI-MIZER SYSTEM IN SUBCOOLING MODE										
Air Entering Evaporator – CFM										
Temp (F) Air Ent Condenser (Edb)		80 dry bulb			80 dry bulb			80 dry bulb		
		72 wet bulb			67 wet bulb			62 wet bulb		
		1200	1600	2000	1200	1600	2000	1200	1600	2000
75	TC	52.5	55.9	58.6	47.1	50.2	52.7	41.7	44.5	46.8
	SHC	22.6	25.5	27.8	27.1	29.9	32.0	31.6	34.2	36.2
	kW	2.5	2.5	2.5	2.5	2.5	2.5	2.5	2.5	2.5
85	TC	48.7	52.2	54.9	43.4	46.5	49.0	38.0	40.8	43.1
	SHC	18.0	21.3	23.9	23.6	26.8	29.2	29.3	32.2	34.4
	kW	2.9	2.9	2.9	2.9	2.9	2.9	2.9	2.9	2.9
95	TC	44.9	48.4	51.2	39.6	42.8	45.3	34.3	37.1	39.4
	SHC	13.4	17.2	20.0	20.2	23.7	26.4	27.0	30.2	32.7
	kW	3.4	3.4	3.4	3.3	3.3	3.3	3.3	3.3	3.3
105	TC	41.1	44.7	47.5	35.9	39.1	41.7	30.6	33.5	35.8
	SHC	8.8	13.0	16.1	16.7	20.6	23.6	24.6	28.2	31.0
	kW	3.8	3.8	3.8	3.7	3.7	3.7	3.7	3.7	3.7
115	TC	37.4	41.0	43.9	32.1	35.4	38.0	26.8	29.8	32.1
	SHC	4.3	8.8	12.2	13.3	17.5	20.7	22.3	26.2	29.2
	kW	4.2	4.2	4.2	4.2	4.2	4.2	4.1	4.1	4.1

50TC05 (4 TONS) – UNIT WITH HUMIDI-MIZER SYSTEM IN HOT GAS REHEAT MODE										
Air Entering Evaporator – CFM										
Temp (F) Air Ent Condenser (Edb)		75 dry bulb			75 dry bulb			75 dry bulb		
		62.5 wet bulb (50% relative)			64 wet bulb (55% relative)			65.3 wet bulb (60% relative)		
		1200	1600	2000	1200	1600	2000	1200	1600	2000
80	TC	11.6	13.8	15.5	13.5	15.8	17.6	15.2	17.5	19.3
	SHC	-1.0	1.2	3.0	-3.1	-0.8	0.9	-4.8	-2.6	-0.9
	kW	2.5	2.5	2.5	2.5	2.5	2.5	2.5	2.5	2.5
75	TC	12.5	14.6	16.2	14.3	16.4	18.1	15.9	18.1	19.8
	SHC	-0.7	1.4	3.0	-2.7	-0.6	1.1	-4.3	-2.2	-0.6
	kW	2.5	2.5	2.5	2.5	2.5	2.5	2.5	2.5	2.5
70	TC	13.4	15.3	16.8	15.1	17.1	18.7	16.6	18.7	20.3
	SHC	-0.5	1.5	3.0	-2.3	-0.3	1.2	-3.8	-1.9	-0.3
	kW	2.5	2.5	2.5	2.5	2.5	2.5	2.5	2.5	2.5
60	TC	15.1	16.8	18.1	16.7	18.4	19.8	18.1	19.9	21.2
	SHC	0.0	1.7	3.1	-1.5	0.2	1.5	-2.8	-1.1	0.2
	kW	2.6	2.6	2.6	2.6	2.6	2.6	2.6	2.6	2.6
50	TC	16.9	18.3	19.4	18.3	19.8	20.9	19.6	21.0	22.2
	SHC	0.6	2.0	3.1	-0.7	0.7	1.8	-1.8	-0.4	0.7
	kW	2.6	2.6	2.6	2.6	2.6	2.6	2.6	2.6	2.6
40	TC	18.7	19.8	20.7	19.9	21.1	22.0	21.0	22.2	23.2
	SHC	1.1	2.2	3.1	0.1	1.2	2.1	-0.8	0.4	1.3
	kW	2.6	2.6	2.6	2.7	2.7	2.7	2.7	2.7	2.7

LEGEND

- Edb** – Entering Dry–Bulb
- Ewb** – Entering Wet–Bulb
- kW** – Compressor Motor Power Input
- ldb** – Leaving Dry–Bulb
- lwb** – Leaving Wet–Bulb
- SHC** – Sensible Heat Capacity (1000 Btuh) Gross
- TC** – Total Capacity (1000 Btuh) Gross

NOTES:

1. Direct interpolation is permissible. Do not extrapolate.
2. The following formulas may be used:

$$t_{ldb} = t_{edb} - \frac{\text{sensible capacity (Btuh)}}{1.10 \times \text{cfm}}$$

t_{lwb} = Wet–bulb temperature corresponding to enthalpy of air leaving evaporator coil (h_{lwb})

$$h_{lwb} = h_{ewb} - \frac{\text{total capacity (Btuh)}}{4.5 \times \text{cfm}}$$

Where: h_{ewb} = Enthalpy of air entering evaporator coil

50TC*A06 (RTPF)			AMBIENT TEMPERATURE												
			85			95			105			115			
			EAT (db)			EAT (db)			EAT (db)			EAT (db)			
			75	80	85	75	80	85	75	80	85	75	80	85	
1500 Cfm	EAT (wb)	58	TC	52.9	52.9	60.0	49.9	49.9	56.6	46.6	46.6	52.9	43.1	43.1	48.9
			SHC	45.8	52.9	60.0	43.2	49.9	56.6	40.4	46.6	52.9	37.3	43.1	48.9
		62	TC	56.2	56.2	57.6	52.2	52.2	55.7	47.8	47.8	53.5	43.2	43.2	51.0
			SHC	41.8	49.7	57.6	39.9	47.8	55.7	37.8	45.6	53.5	35.5	43.2	51.0
		67	TC	62.4	62.4	62.4	58.8	58.8	58.8	54.4	54.4	54.4	49.5	49.5	49.5
	SHC		34.8	42.8	50.7	33.2	41.2	49.1	31.4	39.3	47.3	29.4	37.3	45.3	
	72	TC	68.2	68.2	68.2	64.8	64.8	64.8	60.8	60.8	60.8	56.2	56.2	56.2	
		SHC	27.2	35.2	43.2	25.9	33.9	41.9	24.4	32.4	40.4	22.6	30.6	38.6	
	76	TC	-	71.1	71.1	-	69.0	69.0	-	65.4	65.4	-	60.9	60.9	
		SHC	-	28.4	36.6	-	27.6	35.9	-	26.3	34.6	-	24.8	33.0	
1750 Cfm	EAT (wb)	58	TC	56.5	56.5	64.0	53.3	53.3	60.4	49.8	49.8	56.5	46.1	46.1	52.3
			SHC	48.9	56.5	64.0	46.1	53.3	60.4	43.1	49.8	56.5	39.9	46.1	52.3
		62	TC	58.5	58.5	63.4	54.4	54.4	61.3	49.9	49.9	58.9	46.1	46.1	54.4
			SHC	45.2	54.3	63.4	43.2	52.2	61.3	41.0	49.9	58.9	37.9	46.1	54.4
		67	TC	64.3	64.3	64.3	60.5	60.5	60.5	56.2	56.2	56.2	51.3	51.3	51.3
	SHC		36.9	46.1	55.2	35.3	44.5	53.7	33.6	42.8	51.9	31.6	40.8	49.9	
	72	TC	69.5	69.5	69.5	66.5	66.5	66.5	62.4	62.4	62.4	57.7	57.7	57.7	
		SHC	27.8	36.9	45.9	26.7	35.9	45.1	25.2	34.5	43.7	23.5	32.8	42.0	
	76	TC	-	72.2	72.2	-	70.1	70.1	-	66.6	66.6	-	-	-	
		SHC	-	29.3	38.9	-	28.6	38.2	-	27.4	36.8	-	-	-	
2000 Cfm	EAT (wb)	58	TC	59.3	59.3	67.3	56.1	56.1	63.6	52.5	52.5	59.5	48.6	48.6	55.1
			SHC	51.4	59.3	67.3	48.6	56.1	63.6	45.4	52.5	59.5	42.1	48.6	55.1
		62	TC	60.1	60.1	68.5	56.2	56.2	66.3	52.5	52.5	62.0	48.7	48.7	57.4
			SHC	48.1	58.3	68.5	46.2	56.2	66.3	43.1	52.5	62.0	39.9	48.7	57.4
		67	TC	65.7	65.7	65.7	61.9	61.9	61.9	57.5	57.5	57.5	52.6	52.6	54.4
	SHC		38.8	49.1	59.5	37.3	47.7	58.1	35.6	46.0	56.4	33.6	44.0	54.4	
	72	TC	70.1	70.1	70.1	67.6	67.6	67.6	63.6	63.6	63.6	58.9	58.9	58.9	
		SHC	28.3	38.1	48.0	27.4	37.7	48.0	26.0	36.4	46.7	24.3	34.7	45.2	
	76	TC	-	72.9	72.9	-	70.8	70.8	-	67.4	67.4	-	-	-	
		SHC	-	30.1	40.7	-	29.3	39.9	-	28.2	38.7	-	-	-	
2250 Cfm	EAT (wb)	58	TC	61.5	61.5	69.8	58.4	58.4	66.2	54.8	54.8	62.1	50.8	50.8	57.6
			SHC	53.2	61.5	69.8	50.5	58.4	66.2	47.4	54.8	62.1	43.9	50.8	57.6
		62	TC	61.6	61.6	72.6	58.4	58.4	68.9	54.8	54.8	64.6	50.8	50.8	59.9
			SHC	50.6	61.6	72.6	47.9	58.4	68.9	45.0	54.8	64.6	41.7	50.8	59.9
		67	TC	66.8	66.8	66.8	63.0	63.0	63.0	58.5	58.5	60.6	53.6	53.6	58.6
	SHC		40.5	52.0	63.4	39.1	50.7	62.3	37.4	49.0	60.6	35.5	47.0	58.6	
	72	TC	70.8	70.8	70.8	68.5	68.5	68.5	64.5	64.5	64.5	59.8	59.8	59.8	
		SHC	28.7	39.5	50.2	28.0	39.3	50.5	26.7	38.1	49.6	25.0	36.6	48.1	
	76	TC	-	73.4	73.4	-	71.2	71.2	-	67.9	67.9	-	-	-	
		SHC	-	30.7	42.1	-	30.0	41.4	-	28.9	40.4	-	-	-	
2500 Cfm	EAT (wb)	58	TC	63.3	63.3	71.8	60.1	60.1	68.2	56.5	56.5	64.1	52.6	52.6	59.6
			SHC	54.8	63.3	71.8	52.1	60.1	68.2	49.0	56.5	64.1	45.5	52.6	59.6
		62	TC	63.4	63.4	74.7	60.2	60.2	71.0	56.6	56.6	66.7	52.6	52.6	62.1
			SHC	52.0	63.4	74.7	49.4	60.2	71.0	46.5	56.6	66.7	43.2	52.6	62.1
		67	TC	67.6	67.6	67.6	63.8	63.8	66.2	59.3	59.3	64.6	54.4	54.4	62.5
	SHC		42.1	54.6	67.1	40.9	53.5	66.2	39.2	51.9	64.6	37.2	49.8	62.5	
	72	TC	71.3	71.3	71.3	69.0	69.0	69.0	65.1	65.1	65.1	60.4	60.4	60.4	
		SHC	29.1	40.7	52.2	28.5	40.7	52.9	27.3	39.7	52.2	25.7	38.3	50.9	
	76	TC	-	73.8	73.8	-	71.4	71.4	-	68.3	68.3	-	-	-	
		SHC	-	31.2	43.3	-	30.5	42.6	-	29.6	41.9	-	-	-	

LEGEND:

- Do not operate
- Cfm - Cubic feet per minute (supply air)
- EAT(db) - Entering air temperature (dry bulb)
- EAT(wb) - Entering air temperature (wet bulb)
- SHC - Sensible heat capacity
- TC - Total capacity

50TC06 (5 TONS) – UNIT WITH HUMIDI-MIZER SYSTEM IN SUBCOOLING MODE										
Air Entering Evaporator – CFM										
Temp (F) Air Ent Condenser (Edb)		80 dry bulb			80 dry bulb			80 dry bulb		
		72 wet bulb			67 wet bulb			62 wet bulb		
		1750	2000	2250	1750	2000	2250	1750	2000	2250
75	TC	73.1	78.7	84.5	63.2	66.9	70.8	53.2	55.1	57.1
	SHC	35.3	37.2	38.8	42.0	43.7	45.3	48.7	50.3	51.8
	kW	3.3	3.3	3.3	3.3	3.3	3.3	3.3	3.3	3.3
85	TC	67.6	71.2	75.0	59.1	61.2	63.3	50.6	51.1	51.5
	SHC	27.9	30.0	31.9	36.3	38.3	40.1	44.8	46.6	48.2
	kW	3.8	3.8	3.8	3.8	3.8	3.8	3.8	3.8	3.8
95	TC	62.1	63.8	65.5	55.1	55.4	55.8	48.0	47.0	46.0
	SHC	20.5	22.9	24.9	30.7	32.9	34.8	40.9	42.9	44.7
	kW	4.3	4.3	4.3	4.3	4.3	4.3	4.3	4.3	4.3
105	TC	56.6	56.3	56.0	51.0	49.6	48.3	45.4	43.0	40.5
	SHC	13.1	15.7	18.0	25.0	27.5	29.6	36.9	39.2	41.2
	kW	4.8	4.8	4.8	4.8	4.8	4.8	4.7	4.7	4.7
115	TC	51.1	48.8	46.5	46.9	43.9	40.7	42.8	39.0	35.0
	SHC	5.8	8.6	11.0	19.4	22.0	24.4	33.0	35.5	37.7
	kW	5.3	5.3	5.3	5.3	5.3	5.3	5.2	5.2	5.2

50TC06 (5 TONS) – UNIT WITH HUMIDI-MIZER SYSTEM IN HOT GAS REHEAT MODE										
Air Entering Evaporator – CFM										
Temp (F) Air Ent Condenser (Edb)		75 dry bulb			75 dry bulb			75 dry bulb		
		62.5 wet bulb (50% relative)			64 wet bulb (55% relative)			65.3 wet bulb (60% relative)		
		1750	2000	2250	1750	2000	2250	1750	2000	2250
80	TC	23.0	24.4	25.6	24.7	26.2	27.4	26.3	27.7	29.0
	SHC	5.3	6.1	6.8	3.2	4.0	4.7	1.4	2.2	2.9
	kW	2.9	2.9	2.9	2.9	2.9	2.9	2.9	2.9	2.9
75	TC	23.3	24.6	25.7	25.0	26.3	27.5	26.4	27.8	29.0
	SHC	5.1	5.8	6.5	3.1	3.9	4.5	1.4	2.2	2.8
	kW	2.9	2.9	2.9	2.9	2.9	2.9	2.9	2.9	2.9
70	TC	23.5	24.8	25.9	25.2	26.4	27.5	26.6	27.9	29.0
	SHC	4.8	5.5	6.2	3.0	3.7	4.3	1.4	2.1	2.8
	kW	3.0	3.0	3.0	3.0	3.0	3.0	3.0	3.0	3.0
60	TC	24.1	25.2	26.1	25.6	26.7	27.7	26.9	28.0	29.0
	SHC	4.3	5.0	5.5	2.8	3.4	3.9	1.4	2.0	2.6
	kW	3.0	3.0	3.0	3.0	3.0	3.0	3.0	3.0	3.0
50	TC	24.7	25.6	26.4	26.1	27.0	27.8	27.2	28.2	29.0
	SHC	3.8	4.4	4.8	2.5	3.1	3.5	1.4	2.0	2.4
	kW	3.1	3.1	3.1	3.1	3.1	3.1	3.1	3.1	3.1
40	TC	25.3	26.0	26.7	26.5	27.3	27.9	27.6	28.3	29.0
	SHC	3.3	3.8	4.2	2.3	2.8	3.1	1.4	1.9	2.3
	kW	3.1	3.1	3.1	3.2	3.2	3.2	3.2	3.2	3.2

LEGEND

- Edb** – Entering Dry–Bulb
- Ewb** – Entering Wet–Bulb
- kW** – Compressor Motor Power Input
- ldb** – Leaving Dry–Bulb
- lwb** – Leaving Wet–Bulb
- SHC** – Sensible Heat Capacity (1000 Btuh) Gross
- TC** – Total Capacity (1000 Btuh) Gross

NOTES:

1. Direct interpolation is permissible. Do not extrapolate.
2. The following formulas may be used:

$$t_{ldb} = t_{edb} - \frac{\text{sensible capacity (Btuh)}}{1.10 \times \text{cfm}}$$

t_{lwb} = Wet–bulb temperature corresponding to enthalpy of air leaving evaporator coil (h_{lwb})

$$h_{lwb} = h_{ewb} - \frac{\text{total capacity (Btuh)}}{4.5 \times \text{cfm}}$$

Where: h_{ewb} = Enthalpy of air entering evaporator coil

Table 6 - COOLING CAPACITIES (cont.)

1-STAGE COOLING

6 TONS

50TC*A07 (RTPF)			AMBIENT TEMPERATURE												
			85			95			105			115			
			EAT (db)			EAT (db)			EAT (db)			EAT (db)			
			75	80	85	75	80	85	75	80	85	75	80	85	
1800 Cfm	EAT (wb)	58	TC	64.9	64.9	73.3	62.1	62.1	70.0	58.9	58.9	66.4	55.6	55.6	62.7
		SHC	56.6	64.9	73.3	54.1	62.1	70.0	51.4	58.9	66.4	48.5	55.6	62.7	
		62	TC	68.7	68.7	70.3	64.9	64.9	68.5	60.8	60.8	66.4	56.4	56.4	64.0
		SHC	51.7	61.0	70.3	49.9	59.2	68.5	47.9	57.2	66.4	45.7	54.9	64.0	
		67	TC	75.6	75.6	75.6	71.7	71.7	71.7	67.4	67.4	67.4	62.5	62.5	62.5
	SHC	42.8	52.2	61.5	41.2	50.5	59.8	39.3	48.6	58.0	37.2	46.5	55.8		
	72	TC	82.6	82.6	82.6	78.5	78.5	78.5	73.7	73.7	73.7	67.8	67.8	67.8	
	SHC	33.5	42.8	52.2	31.9	41.3	50.6	30.0	39.3	48.6	27.8	36.9	45.9		
	76	TC	-	87.5	87.5	-	83.3	83.3	-	77.7	77.7	-	70.9	70.9	
	SHC	-	35.0	44.9	-	33.5	43.4	-	31.6	41.5	-	29.3	39.1		
2100 Cfm	EAT (wb)	58	TC	68.9	68.9	77.7	65.9	65.9	74.3	62.5	62.5	70.5	58.7	58.7	66.2
		SHC	60.1	68.9	77.7	57.4	65.9	74.3	54.5	62.5	70.5	51.2	58.7	66.2	
		62	TC	70.9	70.9	76.9	67.1	67.1	75.0	63.0	63.0	72.5	58.7	58.7	68.7
		SHC	55.6	66.3	76.9	53.8	64.4	75.0	51.6	62.1	72.5	48.7	58.7	68.7	
		67	TC	77.8	77.8	77.8	73.7	73.7	73.7	69.2	69.2	69.2	64.0	64.0	64.0
	SHC	45.4	56.1	66.8	43.7	54.4	65.2	41.8	52.5	63.2	39.6	50.2	60.7		
	72	TC	84.5	84.5	84.5	80.3	80.3	80.3	75.1	75.1	75.1	68.8	68.8	68.8	
	SHC	34.5	45.2	55.9	32.9	43.5	54.2	30.9	41.4	52.0	28.5	38.7	48.9		
	76	TC	-	89.2	89.2	-	84.7	84.7	-	78.8	78.8	-	71.6	71.6	
	SHC	-	36.3	47.8	-	34.7	46.0	-	32.6	43.7	-	30.1	40.9		
2400 Cfm	EAT (wb)	58	TC	72.0	72.0	81.2	68.7	68.7	77.5	65.2	65.2	73.5	61.1	61.1	68.9
		SHC	62.8	72.0	81.2	60.0	68.7	77.5	56.9	65.2	73.5	53.3	61.1	68.9	
		62	TC	72.8	72.8	82.8	68.9	68.9	80.7	65.2	65.2	76.4	61.2	61.2	71.6
		SHC	59.1	71.0	82.8	57.2	68.9	80.7	54.1	65.2	76.4	50.7	61.2	71.6	
		67	TC	79.4	79.4	79.4	75.2	75.2	75.2	70.5	70.5	70.5	65.1	65.1	65.3
	SHC	47.7	59.8	71.8	46.0	58.1	70.2	44.0	56.0	68.1	41.6	53.5	65.3		
	72	TC	86.0	86.0	86.0	81.6	81.6	81.6	76.1	76.1	76.1	69.6	69.6	69.6	
	SHC	35.3	47.2	59.2	33.7	45.6	57.5	31.7	43.3	55.0	29.1	40.3	51.4		
	76	TC	-	90.3	90.3	-	85.7	85.7	-	79.6	79.6	-	72.1	72.1	
	SHC	-	37.3	49.8	-	35.6	48.0	-	33.5	45.6	-	30.8	42.5		
2700 Cfm	EAT (wb)	58	TC	60.3	60.3	74.1	71.1	71.1	80.2	67.4	67.4	76.0	63.0	63.0	71.1
		SHC	46.4	60.3	74.1	62.0	71.1	80.2	58.8	67.4	76.0	55.0	63.0	71.1	
		62	TC	65.4	65.4	69.3	71.2	71.2	83.3	67.5	67.5	79.0	63.1	63.1	73.8
		SHC	41.0	55.1	69.3	59.0	71.2	83.3	55.9	67.5	79.0	52.3	63.1	73.8	
		67	TC	72.7	72.7	72.7	76.3	76.3	76.3	71.5	71.5	72.6	65.8	65.8	69.4
	SHC	33.8	48.0	62.2	48.2	61.6	74.9	46.1	59.3	72.6	43.5	56.5	69.4		
	72	TC	79.7	79.7	79.7	82.5	82.5	82.5	76.9	76.9	76.9	70.1	70.1	70.1	
	SHC	25.8	40.2	54.6	34.5	47.5	60.5	32.3	45.0	57.7	29.7	41.7	53.8		
	76	TC	-	85.1	85.1	-	86.4	86.4	-	80.2	80.2	-	72.5	72.5	
	SHC	-	33.5	48.4	-	36.5	49.9	-	34.3	47.3	-	31.5	44.0		
3000 Cfm	EAT (wb)	58	TC	64.9	64.9	78.8	73.1	73.1	82.5	69.2	69.2	78.0	64.5	64.5	72.7
		SHC	51.1	64.9	78.8	63.8	73.1	82.5	60.3	69.2	78.0	56.2	64.5	72.7	
		62	TC	68.7	68.7	76.5	73.2	73.2	85.7	69.2	69.2	81.0	64.5	64.5	75.5
		SHC	45.5	61.0	76.5	60.7	73.2	85.7	57.4	69.2	81.0	53.5	64.5	75.5	
		67	TC	75.6	75.6	75.6	77.2	77.2	79.4	72.2	72.2	76.8	66.3	66.3	73.0
	SHC	36.6	52.2	67.7	50.2	64.8	79.4	48.0	62.4	76.8	45.1	59.1	73.0		
	72	TC	82.6	82.6	82.6	83.3	83.3	83.3	77.5	77.5	77.5	70.5	70.5	70.5	
	SHC	27.2	42.8	58.5	35.1	49.2	63.3	32.9	46.6	60.3	30.2	43.0	55.9		
	76	TC	-	87.5	87.5	-	86.9	86.9	-	80.6	80.6	-	72.8	72.8	
	SHC	-	35.0	51.5	-	37.3	51.6	-	35.0	48.9	-	32.1	45.3		

LEGEND:

- Do not operate in this region
- Cfm - Cubic feet per minute (supply air)
- EAT(db) - Entering air temperature (dry bulb)
- EAT(wb) - Entering air temperature (wet bulb)
- SHC - Sensible heat capacity
- TC - Total capacity

50TC07 (6 TONS) – UNIT WITH HUMIDI-MIZER SYSTEM IN SUBCOOLING MODE										
Air Entering Evaporator – CFM										
Temp (F) Air Ent Condenser (Edb)		80 dry bulb			80 dry bulb			80 dry bulb		
		72 wet bulb			67 wet bulb			62 wet bulb		
		2100	2400	2700	2100	2400	2700	2100	2400	2700
75	TC	86.7	89.9	92.8	79.3	82.3	84.9	71.9	74.6	77.0
	SHC	40.1	41.8	43.3	46.9	48.5	49.9	53.7	55.2	56.5
	kW	4.3	4.3	4.3	4.2	4.2	4.2	4.2	4.2	4.2
85	TC	79.5	82.6	85.4	72.5	75.3	77.9	65.4	68.0	70.3
	SHC	32.1	34.0	35.7	40.7	42.5	44.1	49.4	51.0	52.5
	kW	5.0	5.0	5.0	5.0	5.0	5.0	4.9	4.9	4.9
95	TC	72.4	75.3	78.1	65.6	68.3	70.8	58.8	61.3	63.6
	SHC	24.1	26.3	28.1	34.6	36.6	38.3	45.1	46.9	48.5
	kW	5.8	5.8	5.8	5.7	5.7	5.7	5.6	5.6	5.6
105	TC	65.2	68.1	70.7	58.7	61.4	63.8	52.3	54.7	56.8
	SHC	16.2	18.5	20.5	28.5	30.6	32.6	40.7	42.8	44.6
	kW	6.5	6.5	6.5	6.4	6.4	6.4	6.3	6.3	6.3
115	TC	58.0	60.8	63.3	51.9	54.4	56.7	45.7	48.0	50.1
	SHC	8.2	10.7	13.0	22.3	24.7	26.8	36.4	38.6	40.6
	kW	7.2	7.2	7.2	7.1	7.1	7.1	7.0	7.0	7.0

50TC07 (6 TONS) – UNIT WITH HUMIDI-MIZER SYSTEM IN HOT GAS REHEAT MODE										
Air Entering Evaporator – CFM										
Temp (F) Air Ent Condenser (Edb)		75 dry bulb			75 dry bulb			75 dry bulb		
		62.5 wet bulb (50% relative)			64 wet bulb (55% relative)			65.3 wet bulb (60% relative)		
		2100	2400	2700	2100	2400	2700	1750	2000	2700
80	TC	16.7	19.8	22.5	18.8	21.9	24.7	16.2	19.4	26.7
	SHC	0.6	0.6	0.6	-0.4	-0.4	-0.4	-1.3	-1.3	-1.3
	kW	4.0	4.0	4.0	4.0	4.0	4.0	4.0	4.0	4.0
75	TC	17.7	20.6	23.1	19.6	22.6	25.3	17.3	20.3	27.1
	SHC	0.6	0.6	0.6	-0.3	-0.3	-0.3	-1.2	-1.2	-1.2
	kW	4.0	4.0	4.0	4.0	4.0	4.0	4.0	4.0	4.0
70	TC	18.6	21.3	23.7	20.5	23.3	25.8	18.3	21.1	27.6
	SHC	0.7	0.7	0.7	-0.2	-0.2	-0.2	-1.0	-1.0	-1.0
	kW	4.0	4.0	4.0	4.1	4.1	4.1	4.1	4.1	4.1
60	TC	20.5	22.9	25.0	22.2	24.7	26.8	20.4	22.8	28.5
	SHC	0.7	0.7	0.7	-0.0	-0.0	-0.0	-0.7	-0.7	-0.7
	kW	4.1	4.1	4.1	4.1	4.1	4.1	4.1	4.1	4.1
50	TC	22.4	24.4	26.2	24.0	26.0	27.9	22.4	24.5	29.3
	SHC	0.8	0.8	0.8	0.1	0.1	0.1	-0.4	-0.4	-0.4
	kW	4.1	4.1	4.1	4.1	4.1	4.1	4.2	4.2	4.2
40	TC	24.3	25.9	27.4	25.7	27.4	28.9	24.5	26.3	30.2
	SHC	0.8	0.8	0.8	0.3	0.3	0.3	-0.1	-0.1	-0.1
	kW	4.1	4.1	4.1	4.2	4.2	4.2	4.2	4.2	4.2

LEGEND

- Edb** – Entering Dry–Bulb
- Ewb** – Entering Wet–Bulb
- kW** – Compressor Motor Power Input
- ldb** – Leaving Dry–Bulb
- lwb** – Leaving Wet–Bulb
- SHC** – Sensible Heat Capacity (1000 Btuh) Gross
- TC** – Total Capacity (1000 Btuh) Gross

NOTES:

1. Direct interpolation is permissible. Do not extrapolate.
2. The following formulas may be used:

$$t_{ldb} = t_{edb} - \frac{\text{sensible capacity (Btuh)}}{1.10 \times \text{cfm}}$$

t_{lwb} = Wet–bulb temperature corresponding to enthalpy of air leaving evaporator coil (h_{lwb})

$$h_{lwb} = h_{ewb} - \frac{\text{total capacity (Btuh)}}{4.5 \times \text{cfm}}$$

Where: h_{ewb} = Enthalpy of air entering evaporator coil

Table 6 - COOLING CAPACITIES (cont.)

1-STAGE COOLING

7.5 TONS

50TC*A08 (RTPF)			AMBIENT TEMPERATURE												
			85			95			105			115			
			EAT (db)			EAT (db)			EAT (db)			EA (db)			
			75	80	85	75	80	85	75	80	85	75	80	85	
2250 Cfm	EAT (wb)	58	TC	81.2	81.2	91.8	77.5	77.5	87.7	73.6	73.6	83.3	69.5	69.5	78.7
			SHC	70.5	81.2	91.8	67.3	77.5	87.7	63.9	73.6	83.3	60.4	69.5	78.7
		62	TC	86.9	86.9	86.9	82.3	82.3	84.0	77.2	77.2	81.5	71.9	71.9	78.8
			SHC	63.6	74.9	86.2	61.4	72.7	84.0	58.9	70.2	81.5	56.3	67.6	78.8
		67	TC	95.2	95.2	95.2	90.7	90.7	90.7	85.7	85.7	85.7	79.9	79.9	79.9
		SHC	52.8	64.2	75.6	50.9	62.2	73.6	48.8	60.1	71.5	46.3	57.6	68.9	
	72	TC	103.5	103.5	103.5	98.9	98.9	98.9	93.8	93.8	93.8	87.3	87.3	87.3	
		SHC	41.5	53.1	64.6	39.7	51.2	62.7	37.7	49.2	60.6	35.3	46.6	57.8	
	76	TC	-	109.6	109.6	-	104.8	104.8	-	99.1	99.1	-	91.6	91.6	
		SHC	-	43.7	56.0	-	42.0	54.3	-	40.0	52.4	-	37.4	49.8	
2625 Cfm	EAT (wb)	58	TC	85.9	85.9	97.2	82.2	82.2	93.1	78.1	78.1	88.4	73.9	73.9	83.6
			SHC	74.6	85.9	97.2	71.4	82.2	93.1	67.9	78.1	88.4	64.1	73.9	83.6
		62	TC	89.6	89.6	94.1	85.1	85.1	91.7	80.1	80.1	89.1	74.6	74.6	86.0
			SHC	68.1	81.1	94.1	65.9	78.8	91.7	63.4	76.3	89.1	60.6	73.3	86.0
		67	TC	97.9	97.9	97.9	93.2	93.2	93.2	88.1	88.1	88.1	82.0	82.0	82.0
		SHC	55.7	68.7	81.7	53.7	66.7	79.8	51.6	64.6	77.6	49.0	62.0	74.9	
	72	TC	106.0	106.0	106.0	101.3	101.3	101.3	95.9	95.9	95.9	89.0	89.0	89.0	
		SHC	42.7	55.8	68.9	40.9	53.9	67.0	38.8	51.8	64.7	36.2	48.9	61.7	
	76	TC	-	111.8	111.8	-	106.9	106.9	-	100.7	100.7	-	92.7	92.7	
		SHC	-	45.3	59.8	-	43.6	58.0	-	41.4	55.6	-	38.7	52.6	
3000 Cfm	EAT (wb)	58	TC	89.6	89.6	101.4	85.9	85.9	97.2	81.7	81.7	92.5	77.0	77.0	87.1
			SHC	77.9	89.6	101.4	74.6	85.9	97.2	71.0	81.7	92.5	66.9	77.0	87.1
		62	TC	91.8	91.8	101.1	87.2	87.2	98.6	82.3	82.3	95.5	77.1	77.1	90.6
			SHC	72.2	86.7	101.1	69.9	84.3	98.6	67.2	81.3	95.5	63.5	77.1	90.6
		67	TC	99.9	99.9	99.9	95.2	95.2	95.2	89.9	89.9	89.9	83.6	83.6	83.6
		SHC	58.3	72.9	87.5	56.4	71.0	85.5	54.2	68.8	83.4	51.6	66.1	80.5	
	72	TC	107.9	107.9	107.9	103.0	103.0	103.0	97.3	97.3	97.3	90.1	90.1	90.1	
		SHC	43.7	58.3	72.8	41.9	56.4	70.9	39.7	54.1	68.4	37.0	51.0	65.0	
	76	TC	-	113.8	113.8	-	108.4	108.4	-	102.0	102.0	-	93.4	93.4	
		SHC	-	46.7	62.5	-	44.8	60.4	-	42.6	57.9	-	39.6	54.7	
3375 Cfm	EAT (wb)	58	TC	92.7	92.7	104.9	88.8	88.8	100.5	84.6	84.6	95.7	79.6	79.6	90.0
			SHC	80.5	92.7	104.9	77.1	88.8	100.5	73.4	84.6	95.7	69.1	79.6	90.0
		62	TC	93.7	93.7	107.3	89.1	89.1	104.7	84.6	84.6	99.5	79.6	79.6	93.6
			SHC	75.8	91.6	107.3	73.5	89.1	104.7	69.8	84.6	99.5	65.6	79.6	93.6
		67	TC	101.5	101.5	101.5	96.7	96.7	96.7	91.3	91.3	91.3	84.8	84.8	85.7
		SHC	60.8	76.9	93.0	58.8	74.9	91.0	56.7	72.8	88.9	53.9	69.8	85.7	
	72	TC	109.4	109.4	109.4	104.3	104.3	104.3	98.4	98.4	98.4	90.9	90.9	90.9	
		SHC	44.6	60.5	76.4	42.8	58.6	74.4	40.5	56.2	71.8	37.7	52.8	68.0	
	76	TC	-	115.1	115.1	-	109.5	109.5	-	102.8	102.8	-	94.0	94.0	
		SHC	-	47.8	64.9	-	45.9	62.7	-	43.5	60.1	-	40.4	56.5	
3750 Cfm	EAT (wb)	58	TC	95.3	95.3	107.8	91.3	91.3	103.3	86.9	86.9	98.3	81.7	81.7	92.4
			SHC	82.7	95.3	107.8	79.3	91.3	103.3	75.5	86.9	98.3	70.9	81.7	92.4
		62	TC	95.5	95.5	112.2	91.3	91.3	107.4	87.0	87.0	102.2	81.7	81.7	96.0
			SHC	78.7	95.5	112.2	75.3	91.3	107.4	71.7	87.0	102.2	67.4	81.7	96.0
		67	TC	102.8	102.8	102.8	97.9	97.9	97.9	92.3	92.3	94.0	85.7	85.7	90.5
		SHC	63.1	80.6	98.2	61.2	78.7	96.3	59.0	76.5	94.0	56.0	73.2	90.5	
	72	TC	110.6	110.6	110.6	105.4	105.4	105.4	99.2	99.2	99.2	91.5	91.5	91.5	
		SHC	45.5	62.7	79.9	43.5	60.7	77.8	41.3	58.1	75.0	38.3	54.5	70.7	
	76	TC	-	116.1	116.1	-	110.3	110.3	-	103.5	103.5	-	94.5	94.5	
		SHC	-	48.9	67.0	-	46.8	64.8	-	44.4	62.0	-	41.1	58.1	

LEGEND:

- Do not operate in this region
- Cfm - Cubic feet per minute (supply air)
- EAT(db) - Entering air temperature (dry bulb)
- EAT(wb) - Entering air temperature (wet bulb)
- SHC - Sensible heat capacity
- TC - Total capacity

Table 6 - COOLING CAPACITIES (cont.)

2-STAGE COOLING

7.5 TONS

50TC*D08 (RTPF & Novation)				AMBIENT TEMPERATURE											
				85			95			105			115		
				EAT (db)			EAT (db)			EAT (db)			EA (db)		
				75	80	85	75	80	85	75	80	85	75	80	85
2250 Cfm	EAT (wb)	58	TC	77.4	77.4	87.8	73.8	73.8	83.8	70.1	70.1	79.5	66.0	66.0	74.9
			SHC	66.9	77.4	87.8	63.9	73.8	83.8	60.6	70.1	79.5	57.1	66.0	74.9
		62	TC	82.2	82.2	83.9	77.5	77.5	81.7	72.6	72.6	79.2	67.3	67.3	76.4
			SHC	60.8	72.4	83.9	58.6	70.1	81.7	56.3	67.7	79.2	53.6	65.0	76.4
		67	TC	90.1	90.1	90.1	86.0	86.0	86.0	81.4	81.4	81.4	75.9	75.9	75.9
			SHC	50.2	61.8	73.3	48.5	60.1	71.6	46.5	58.1	69.7	44.2	55.8	67.4
		72	TC	98.0	98.0	98.0	94.0	94.0	94.0	89.5	89.5	89.5	84.3	84.3	84.3
			SHC	39.1	50.7	62.4	37.5	49.2	60.9	35.8	47.5	59.2	33.8	45.5	57.2
		76	TC	-	104.3	104.3	-	100.4	100.4	-	95.9	95.9	-	90.7	90.7
			SHC	-	41.7	54.0	-	40.3	52.7	-	38.7	51.0	-	36.8	49.0
2625 Cfm	EAT (wb)	58	TC	82.1	82.1	93.2	78.4	78.4	89.0	74.4	74.4	84.4	70.0	70.0	79.5
			SHC	71.0	82.1	93.2	67.8	78.4	89.0	64.3	74.4	84.4	60.6	70.0	79.5
		62	TC	84.9	84.9	91.8	80.4	80.4	89.5	75.4	75.4	86.7	70.2	70.2	82.9
			SHC	65.4	78.6	91.8	63.2	76.3	89.5	60.6	73.7	86.7	57.6	70.2	82.9
		67	TC	92.5	92.5	92.5	88.3	88.3	88.3	83.6	83.6	83.6	78.3	78.3	78.3
			SHC	53.0	66.3	79.5	51.3	64.6	78.0	49.4	62.8	76.1	47.2	60.6	73.9
		72	TC	100.4	100.4	100.4	96.4	96.4	96.4	91.7	91.7	91.7	86.4	86.4	86.4
			SHC	40.2	53.5	66.7	38.7	52.0	65.3	36.9	50.3	63.7	35.0	48.4	61.8
		76	TC	-	106.5	106.5	-	102.6	102.6	-	98.0	98.0	-	92.7	92.7
			SHC	-	43.3	57.6	-	41.8	55.9	-	40.2	54.1	-	38.4	52.2
3000 Cfm	EAT (wb)	58	TC	85.7	85.7	97.3	82.2	82.2	93.3	78.0	78.0	88.6	73.5	73.5	83.4
			SHC	74.1	85.7	97.3	71.1	82.2	93.3	67.5	78.0	88.6	63.6	73.5	83.4
		62	TC	86.9	86.9	98.7	82.8	82.8	96.4	78.2	78.2	92.3	73.6	73.6	86.9
			SHC	69.3	84.0	98.7	67.2	81.8	96.4	64.1	78.2	92.3	60.3	73.6	86.9
		67	TC	94.3	94.3	94.3	90.1	90.1	90.1	85.2	85.2	85.2	79.8	79.8	80.1
			SHC	55.6	70.5	85.4	54.0	68.9	83.9	52.1	67.1	82.2	49.9	65.0	80.1
		72	TC	102.2	102.2	102.2	98.1	98.1	98.1	93.3	93.3	93.3	87.9	87.9	87.9
			SHC	41.2	56.0	70.7	39.7	54.6	69.5	38.0	53.0	68.0	36.0	51.1	66.2
		76	TC	-	108.1	108.1	-	104.2	104.2	-	99.5	99.5	-	94.2	94.2
			SHC	-	44.5	60.2	-	43.2	58.7	-	41.6	57.0	-	39.8	55.2
3375 Cfm	EAT (wb)	58	TC	88.5	88.5	100.4	85.0	85.0	96.4	81.0	81.0	92	76.5	76.5	86.8
			SHC	76.5	88.5	100.4	73.5	85.0	96.4	70.1	81.0	92	66.1	76.5	86.8
		62	TC	88.9	88.9	103.9	85.1	85.1	100.4	81.1	81.1	95.7	76.5	76.5	90.3
			SHC	72.3	88.1	103.9	69.7	85.1	100.4	66.5	81.1	95.7	62.7	76.5	90.3
		67	TC	95.8	95.8	95.8	91.5	91.5	91.5	86.6	86.6	87.9	81.1	81.1	85.8
			SHC	58.0	74.4	90.9	56.4	73.0	89.6	54.6	71.3	87.9	52.4	69.1	85.8
		72	TC	103.6	103.6	103.6	99.4	99.4	99.4	94.6	94.6	94.6	89.1	89.1	89.1
			SHC	42.0	58.3	74.5	40.6	57.0	73.4	38.9	55.5	72.0	37.0	53.7	70.3
		76	TC	-	109.2	109.2	-	105.4	105.4	-	100.7	100.7	-	95.3	95.3
			SHC	-	45.6	62.6	-	44.4	61.3	-	42.8	59.7	-	41.0	58.0
3750 Cfm	EAT (wb)	58	TC	90.8	90.8	103.0	87.3	87.3	99.1	83.3	83.3	94.5	78.8	78.8	89.4
			SHC	78.5	90.8	103.0	75.5	87.3	99.1	72.0	83.3	94.5	68.2	78.8	89.4
		62	TC	90.9	90.9	107.2	87.4	87.4	103.1	83.3	83.3	98.4	78.9	78.9	93.1
			SHC	74.5	90.9	107.2	71.6	87.4	103.1	68.3	83.3	98.4	64.7	78.9	93.1
		67	TC	97.0	97.0	97.0	92.6	92.6	95.1	87.6	87.6	93.4	82.1	82.1	91.2
			SHC	60.3	78.2	96.2	58.8	76.9	95.1	56.9	75.2	93.4	54.8	73.0	91.2
		72	TC	104.7	104.7	104.7	100.5	100.5	100.5	95.6	95.6	95.6	90.1	90.1	90.1
			SHC	42.9	60.5	78.1	41.4	59.3	77.1	39.8	57.8	75.9	37.9	56.1	74.3
		76	TC	-	110.2	110.2	-	106.2	106.2	-	101.6	101.6	-	96.1	96.1
			SHC	-	46.7	64.8	-	45.4	63.6	-	44.0	62.3	-	42.2	60.6

* See Minimum - Maximum Airflow Ratings in Table 3. Do not operate outside these limits.

LEGEND:

- Do not operate in this region
- Cfm - Cubic feet per minute (supply air)
- EAT(db) - Entering air temperature (dry bulb)
- EAT(wb) - Entering air temperature (wet bulb)
- SHC - Sensible heat capacity
- TC - Total capacity

50TC08 COOLING CAPACITIES, UNIT WITH HUMIDI-MIZER SYSTEM IN SUBCOOLING MODE										
TEMP (F) AIR ENT CONDENSER (Edb)		AIR ENTERING EVAPORATOR – CFM								
		2250/0.05			3000/0.07			3750/0.09		
		Air Entering Evaporator – Ewb (F)								
		72	67	62	72	67	62	72	67	62
75	TC	103.05	93.02	83.60	109.77	99.52	90.08	114.01	103.69	95.19
	SHC	43.66	55.34	67.09	50.99	66.29	81.31	57.49	76.27	92.20
	kW	4.90	4.83	4.77	4.82	4.88	4.96	4.99	4.91	4.85
85	TC	95.39	85.83	76.88	101.59	91.89	82.95	105.53	95.76	87.77
	SHC	36.42	48.47	60.60	43.24	58.99	74.40	49.44	68.68	84.90
	kW	5.49	5.42	5.36	5.40	5.47	5.54	5.58	5.50	5.44
95	TC	87.48	78.44	69.97	93.21	84.05	75.61	96.84	87.63	80.14
	SHC	28.98	41.46	53.97	35.32	51.53	67.34	41.21	60.92	77.41
	kW	6.16	6.09	6.03	6.08	6.14	6.21	6.24	6.17	6.11
105	TC	79.35	70.83	62.84	84.57	75.96	68.04	87.88	79.23	72.26
	SHC	21.34	34.26	47.18	27.17	43.86	60.08	32.73	52.95	69.70
	kW	6.93	6.86	6.81	6.85	6.91	6.97	7.00	6.93	6.88
115	TC	70.87	62.89	55.42	75.58	67.54	60.15	78.56	70.51	64.06
	SHC	13.40	26.79	40.14	18.70	35.89	52.54	23.94	44.68	61.67
	kW	7.79	7.74	7.69	7.73	7.78	7.83	7.86	7.80	7.76

50TC08 COOLING CAPACITIES, UNIT WITH HUMIDI-MIZER SYSTEM IN HOT GAS REHEAT MODE										
TEMP (F) AIR ENT CONDENSER (Edb)		AIR ENTERING EVAPORATOR – Ewb (F)								
		75 Dry Bulb 62.5 Wet Bulb (50% Relative)			75 Dry Bulb 64 Wet Bulb (56% Relative)			75 Dry Bulb 65.3 Wet Bulb (60% Relative)		
		Air Entering Evaporator – Cfm								
		2250	3000	3750	2250	3000	3750	2250	3000	3750
80	TC	27.60	32.75	30.19	40.09	39.43	37.73	45.06	45.25	44.25
	SHC	-3.12	5.20	6.71	3.75	5.24	6.75	3.77	5.26	6.78
	kW	4.56	4.51	4.46	4.63	4.60	4.56	4.70	4.67	4.64
75	TC	35.40	33.78	31.20	41.14	40.51	38.80	46.15	46.37	45.38
	SHC	4.67	6.17	7.69	4.71	6.21	7.73	4.74	6.24	7.76
	kW	4.41	4.36	4.39	4.41	4.36	4.36	4.41	4.39	4.36
70	TC	36.36	34.71	32.18	42.10	41.47	39.77	47.08	47.31	46.32
	SHC	5.63	7.14	8.66	5.67	7.18	8.71	5.70	7.21	8.74
	kW	4.43	4.49	4.41	4.44	4.40	4.39	4.49	4.47	4.44
60	TC	38.25	36.64	34.15	43.97	43.37	41.72	48.98	49.22	48.26
	SHC	7.56	9.09	10.62	7.60	9.13	10.66	7.62	9.15	10.69
	kW	4.56	4.55	4.43	4.57	4.53	4.46	4.56	4.55	4.50
50	TC	40.15	38.60	36.14	45.95	45.37	43.73	50.57	50.97	49.56
	SHC	9.48	11.03	12.58	9.52	11.07	12.62	9.54	11.10	12.64
	kW	4.63	4.52	4.38	4.45	4.41	4.33	5.25	4.91	5.60
40	TC	42.18	40.62	38.11	47.80	47.25	45.43	52.65	52.75	51.83
	SHC	11.41	12.98	14.54	11.45	13.02	14.58	11.47	13.04	14.60
	kW	4.32	4.37	4.37	4.65	4.60	4.89	4.96	5.20	5.12

LEGEND

- Edb** – Entering Dry–Bulb
- Ewb** – Entering Wet–Bulb
- kW** – Compressor Motor Power Input
- ldb** – Leaving Dry–Bulb
- lwb** – Leaving Wet–Bulb
- SHC** – Sensible Heat Capacity (1000 Btuh) Gross
- TC** – Total Capacity (1000 Btuh) Gross

NOTES:

1. Direct interpolation is permissible. Do not extrapolate.
2. The following formulas may be used:

$$t_{db} = t_{edb} - \frac{\text{sensible capacity (Btuh)}}{1.10 \times \text{cfm}}$$

$$t_{lwb} = \text{Wet-bulb temperature corresponding to enthalpy of air leaving evaporator coil } (h_{lwb})$$

$$h_{lwb} = h_{ewb} - \frac{\text{total capacity (Btuh)}}{4.5 \times \text{cfm}}$$
 Where: h_{ewb} = Enthalpy of air entering evaporator coil

Table 6 - COOLING CAPACITIES (cont.)

1-STAGE COOLING

8.5 TONS

50TC*A09 (RTPF)			AMBIENT TEMPERATURE												
			85			95			105			115			
			EAT (db)			EAT (db)			EAT (db)			EAT (db)			
			75	80	85	75	80	85	75	80	85	75	80	85	
2550 Cfm	EAT (wb)	58	TC	88.1	88.1	99.9	84.1	84.1	95.3	79.6	79.6	90.3	74.9	74.9	84.9
			SHC	76.4	88.1	99.9	72.8	84.1	95.3	69.0	79.6	90.3	64.9	74.9	84.9
		62	TC	93.9	93.9	95.2	88.6	88.6	92.6	82.8	82.8	89.7	76.6	76.6	86.5
			SHC	69.4	82.3	95.2	66.8	79.7	92.6	64.1	76.9	89.7	61.0	73.8	86.5
		67	TC	103.8	103.8	103.8	98.7	98.7	98.7	93.0	93.0	93.0	86.7	86.7	86.7
		SHC	57.8	70.7	83.6	55.6	68.5	81.4	53.1	66.1	79.0	50.5	63.4	76.4	
		72	TC	113.1	113.1	113.1	108.0	108.0	108.0	102.4	102.4	102.4	96.1	96.1	96.1
		SHC	45.2	58.3	71.3	43.2	56.3	69.3	41.1	54.1	67.1	38.7	51.7	64.7	
		76	TC	-	119.9	119.9	-	114.7	114.7	-	109.0	109.0	-	102.7	102.7
		SHC	-	47.9	61.9	-	46.0	60.1	-	44.1	58.1	-	41.9	55.8	
2975 Cfm	EAT (wb)	58	TC	93.6	93.6	106.1	89.3	89.3	101.2	84.6	84.6	96.0	79.6	79.6	90.3
			SHC	81.1	93.6	106.1	77.4	89.3	101.2	73.3	84.6	96.0	69.0	79.6	90.3
		62	TC	97.5	97.5	104.3	92.0	92.0	101.4	86.1	86.1	98.3	79.8	79.8	94.1
			SHC	74.7	89.5	104.3	72.0	86.7	101.4	69.1	83.7	98.3	65.6	79.8	94.1
		67	TC	106.7	106.7	106.7	101.5	101.5	101.5	95.7	95.7	95.7	89.2	89.2	89.2
		SHC	61.0	75.8	90.6	58.8	73.6	88.5	56.4	71.3	86.1	53.8	68.7	83.6	
		72	TC	115.8	115.8	115.8	110.6	110.6	110.6	104.9	104.9	104.9	98.4	98.4	98.4
		SHC	46.5	61.3	76.2	44.5	59.4	74.2	42.3	57.2	72.1	40.0	54.8	69.7	
		76	TC	-	122.4	122.4	-	117.0	117.0	-	111.1	111.1	-	104.5	104.5
		SHC	-	49.8	66.1	-	47.8	63.9	-	45.7	61.6	-	43.4	59.0	
3400 Cfm	EAT (wb)	58	TC	98.1	98.1	111.3	93.7	93.7	106.2	88.9	88.9	100.8	83.7	83.7	94.9
			SHC	85.0	98.1	111.3	81.2	93.7	106.2	77.0	88.9	100.8	72.5	83.7	94.9
		62	TC	100.0	100.0	112.3	94.9	94.9	108.6	89.1	89.1	104.9	83.8	83.8	98.7
			SHC	79.3	95.8	112.3	76.3	92.5	108.6	73.2	89.1	104.9	68.8	83.8	98.7
		67	TC	109.0	109.0	109.0	103.6	103.6	103.6	97.6	97.6	97.6	91.0	91.0	91.0
		SHC	63.9	80.5	97.2	61.8	78.5	95.2	59.4	76.1	92.9	56.8	73.5	90.3	
		72	TC	117.9	117.9	117.9	112.5	112.5	112.5	106.6	106.6	106.6	100.0	100.0	100.0
		SHC	47.6	64.1	80.6	45.6	62.1	78.7	43.4	60.0	76.6	41.1	57.6	74.2	
		76	TC	-	124.2	124.2	-	118.6	118.6	-	112.5	112.5	-	105.7	105.7
		SHC	-	51.2	69.0	-	49.2	66.7	-	47.0	64.4	-	44.7	61.9	
3825 Cfm	EAT (wb)	58	TC	101.6	101.6	115.1	97.2	97.2	110.1	92.3	92.3	104.6	87.0	87.0	98.6
			SHC	88.0	101.6	115.1	84.2	97.2	110.1	80.0	92.3	104.6	75.4	87.0	98.6
		62	TC	101.9	101.9	120.0	97.3	97.3	114.6	92.4	92.4	108.9	87.1	87.1	102.6
			SHC	83.7	101.8	120.0	79.9	97.3	114.6	75.9	92.4	108.9	71.6	87.1	102.6
		67	TC	110.7	110.7	110.7	105.3	105.3	105.3	99.2	99.2	99.3	92.5	92.5	96.7
		SHC	66.7	85.0	103.4	64.6	83.0	101.5	62.2	80.8	99.3	59.6	78.2	96.7	
		72	TC	119.4	119.4	119.4	114.0	114.0	114.0	108.0	108.0	108.0	101.3	101.3	101.3
		SHC	48.5	66.6	84.6	46.6	64.7	82.7	44.4	62.6	80.7	42.1	60.2	78.4	
		76	TC	-	125.5	125.5	-	119.8	119.8	-	113.6	113.6	-	106.7	106.7
		SHC	-	52.4	71.5	-	50.4	69.3	-	48.2	67.0	-	45.9	64.4	
4250 Cfm	EAT (wb)	58	TC	104.4	104.4	118.3	99.9	99.9	113.2	95.0	95.0	107.6	89.5	89.5	101.5
			SHC	90.4	104.4	118.3	86.6	99.9	113.2	82.3	95.0	107.6	77.6	89.5	101.5
		62	TC	104.4	104.4	123.0	99.9	99.9	117.8	95.0	95.0	112.0	89.6	89.6	105.6
			SHC	85.8	104.4	123.0	82.1	99.9	117.8	78.1	95.0	112.0	73.6	89.6	105.6
		67	TC	112.1	112.1	112.1	106.6	106.6	107.5	100.4	100.4	105.3	93.6	93.6	102.7
		SHC	69.2	89.2	109.2	67.2	87.3	107.5	64.9	85.1	105.3	62.3	82.5	102.7	
		72	TC	120.7	120.7	120.7	115.1	115.1	115.1	109.0	109.0	109.0	102.2	102.2	102.2
		SHC	49.4	68.9	88.4	47.4	67.0	86.5	45.3	64.9	84.6	42.9	62.6	82.3	
		76	TC	-	126.6	126.6	-	120.8	120.8	-	114.5	114.5	-	107.4	107.4
		SHC	-	53.5	73.9	-	51.5	71.7	-	49.3	69.4	-	46.9	66.8	

LEGEND:

- Do not operate in this region
- Cfm - Cubic feet per minute (supply air)
- EAT(db) - Entering air temperature (dry bulb)
- EAT(wb) - Entering air temperature (wet bulb)
- SHC - Sensible heat capacity
- TC - Total capacity

Table 6 - COOLING CAPACITIES (cont.)

2-STAGE COOLING

8.5 TONS

50TC*D09 (RTPF)			AMBIENT TEMPERATURE												
			85			95			105			115			
			EA (dB)			EA (dB)			EA (dB)			EA (dB)			
			75	80	85	75	80	85	75	80	85	75	80	85	
2550 Cfm	EAT (wb)	58	TC	89.7	89.7	101.6	85.2	85.2	96.5	79.6	79.6	90.1	73.8	73.8	83.6
			SHC	77.8	89.7	101.6	73.9	85.2	96.5	69.0	79.6	90.1	64.0	73.8	83.6
		62	TC	94.3	94.3	97.9	88.7	88.7	95.2	81.3	81.3	91.5	74.3	74.3	86.5
			SHC	71.0	84.4	97.9	68.2	81.7	95.2	64.7	78.1	91.5	60.6	73.6	86.5
		67	TC	105.0	105.0	105.0	99.3	99.3	99.3	92.2	92.2	92.2	84.1	84.1	84.1
	SHC		59.0	72.6	86.1	56.6	70.1	83.7	53.6	67.1	80.7	50.3	63.8	77.3	
	72	TC	115.9	115.9	115.9	110.4	110.4	110.4	104.2	104.2	104.2	96.0	96.0	96.0	
		SHC	46.4	60.0	73.6	44.3	57.9	71.5	41.9	55.5	69.1	38.8	52.4	65.9	
	76	TC	-	123.7	123.7	-	118.3	118.3	-	112.4	112.4	-	105.7	105.7	
		SHC	-	49.3	63.3	-	47.3	61.4	-	45.3	59.3	-	42.9	56.7	
2975 Cfm	EAT (wb)	58	TC	95.3	95.3	107.9	90.7	90.7	102.7	84.8	84.8	96.1	78.7	78.7	89.1
			SHC	82.6	95.3	107.9	78.6	90.7	102.7	73.5	84.8	96.1	68.2	78.7	89.1
		62	TC	97.9	97.9	107.8	92.1	92.1	104.7	85.4	85.4	99.4	78.8	78.8	92.8
			SHC	76.7	92.2	107.8	73.9	89.3	104.7	69.6	84.5	99.4	64.8	78.8	92.8
		67	TC	108.5	108.5	108.5	102.6	102.6	102.6	95.4	95.4	95.4	86.9	86.9	86.9
	SHC		62.8	78.4	94.1	60.4	76.0	91.7	57.4	73.1	88.8	54.0	69.7	85.3	
	72	TC	119.1	119.1	119.1	113.5	113.5	113.5	107.2	107.2	107.2	99.2	99.2	99.2	
		SHC	47.9	63.5	79.2	45.8	61.5	77.1	43.5	59.2	74.9	40.6	56.3	72.0	
	76	TC	-	126.4	126.4	-	120.8	120.8	-	114.8	114.8	-	108.2	108.2	
		SHC	-	51.1	67.4	-	49.2	65.3	-	47.0	63.0	-	44.8	60.7	
3400 Cfm	EAT (wb)	58	TC	100.0	100.0	113.3	95.2	95.2	107.9	89.3	89.3	101.1	82.9	82.9	93.9
			SHC	86.7	100.0	113.3	82.6	95.2	107.9	77.4	89.3	101.1	71.8	82.9	93.9
		62	TC	101.1	101.1	115.8	95.7	95.7	111.7	89.4	89.4	105.3	83.0	83.0	97.7
			SHC	81.5	98.7	115.8	78.2	94.9	111.7	73.5	89.4	105.3	68.2	83.0	97.7
		67	TC	111.1	111.1	111.1	105.1	105.1	105.1	97.8	97.8	97.8	89.1	89.1	93.0
	SHC		66.2	83.9	101.6	63.9	81.6	99.3	61.0	78.7	96.5	57.5	75.3	93.0	
	72	TC	121.3	121.3	121.3	115.6	115.6	115.6	109.4	109.4	109.4	101.5	101.5	101.5	
		SHC	49.2	66.7	84.3	47.1	64.7	82.3	44.9	62.5	80.2	42.1	59.9	77.7	
	76	TC	-	128.3	128.3	-	122.6	122.6	-	116.3	116.3	-	109.7	109.7	
		SHC	-	52.7	70.7	-	50.7	68.6	-	48.6	66.4	-	46.4	64.2	
3825 Cfm	EAT (wb)	58	TC	104.0	104.0	117.8	99.1	99.1	112.3	93.2	93.2	105.5	86.5	86.5	97.9
			SHC	90.2	104.0	117.8	86.0	99.1	112.3	80.8	93.2	105.5	75.0	86.5	97.9
		62	TC	104.2	104.2	122.7	99.3	99.3	116.9	93.3	93.3	109.8	86.6	86.6	101.9
			SHC	85.7	104.2	122.7	81.7	99.3	116.9	76.7	93.3	109.8	71.2	86.6	101.9
		67	TC	113.1	113.1	113.1	107.1	107.1	107.1	99.9	99.9	103.8	91.0	91.0	100.3
	SHC		69.4	89.1	108.8	67.1	86.8	106.5	64.3	84.1	103.8	60.9	80.6	100.3	
	72	TC	123.0	123.0	123.0	117.2	117.2	117.2	110.9	110.9	110.9	103.3	103.3	103.3	
		SHC	50.3	69.7	89.0	48.3	67.7	87.1	46.1	65.6	85.2	43.5	63.3	83.0	
	76	TC	-	129.7	129.7	-	124.0	124.0	-	117.5	117.5	-	110.8	110.8	
		SHC	-	54.0	73.7	-	52.1	71.7	-	50.0	69.5	-	47.8	67.4	
4250 Cfm	EAT (wb)	58	TC	107.4	107.4	121.7	102.5	102.5	116.1	96.5	96.5	109.3	89.5	89.5	101.4
			SHC	93.1	107.4	121.7	88.9	102.5	116.1	83.7	96.5	109.3	77.6	89.5	101.4
		62	TC	107.5	107.5	126.6	102.6	102.6	120.8	96.6	96.6	113.7	89.6	89.6	105.5
			SHC	88.4	107.5	126.6	84.4	102.6	120.8	79.5	96.6	113.7	73.7	89.6	105.5
		67	TC	114.7	114.7	115.6	108.7	108.7	113.5	101.7	101.7	110.8	92.6	92.6	107.2
	SHC		72.5	94.0	115.6	70.2	91.8	113.5	67.5	89.2	110.8	64.0	85.6	107.2	
	72	TC	124.3	124.3	124.3	118.5	118.5	118.5	112.1	112.1	112.1	104.7	104.7	104.7	
		SHC	51.3	72.4	93.4	49.3	70.5	91.7	47.2	68.5	89.9	44.7	66.4	88.1	
	76	TC	-	130.7	130.7	-	125.0	125.0	-	118.5	118.5	-	111.6	111.6	
		SHC	-	55.3	76.5	-	53.5	74.6	-	51.3	72.4	-	49.2	70.3	

* See Minimum–Maximum Airflow Ratings in Table 3. Do not operate outside these limits.

LEGEND:

- Do not operate in this region
- Cfm - Cubic feet per minute (supply air)
- EAT(db) - Entering air temperature (dry bulb)
- EAT(wb) - Entering air temperature (wet bulb)
- SHC - Sensible heat capacity
- TC - Total capacity

Table 6 - COOLING CAPACITIES (cont.) 2-STAGE COOLING

8.5 TONS

50TC09 COOLING CAPACITIES, UNIT WITH HUMIDI-MIZER SYSTEM IN SUBCOOLING MODE										
TEMP (F) AIR ENT CONDENSER (Edb)		AIR ENTERING EVAPORATOR – CFM								
		2550/0.04			3400/0.05			4250/0.07		
		Air Entering Evaporator – Ewb (F)								
		72	67	62	72	67	62	72	67	62
75	TC	119.20	107.44	96.41	126.95	114.98	103.92	131.87	119.81	109.54
	SHC	50.63	63.94	77.40	59.17	76.72	94.21	66.80	88.44	108.22
	kW	5.67	5.57	5.47	5.54	5.63	5.74	5.79	5.68	5.59
85	TC	110.40	99.22	88.76	117.63	106.26	95.77	122.21	110.77	101.07
	SHC	42.39	56.16	70.07	50.42	68.45	86.38	57.71	79.86	99.95
	kW	6.33	6.23	6.14	6.20	6.30	6.40	6.45	6.34	6.25
95	TC	101.37	90.79	80.86	108.07	97.31	87.39	112.29	101.47	92.38
	SHC	33.97	48.22	62.56	41.46	60.01	78.39	48.40	71.09	91.47
	kW	7.08	6.99	6.90	6.96	7.05	7.16	7.20	7.09	7.01
105	TC	92.04	82.06	72.71	98.19	88.05	78.72	102.07	91.86	83.40
	SHC	25.31	40.06	54.88	32.24	51.33	70.17	38.85	62.06	82.67
	kW	7.94	7.85	7.77	7.83	7.91	8.01	8.06	7.95	7.87
115	TC	82.37	73.01	64.24	87.95	78.45	69.73	91.46	81.90	74.09
	SHC	16.38	31.65	46.95	22.71	42.37	61.69	28.94	52.74	73.52
	kW	8.92	8.84	8.77	8.82	8.89	8.98	9.02	8.93	8.86

50TC09 COOLING CAPACITIES, UNIT WITH HUMIDI-MIZER SYSTEM IN HOT GAS REHEAT MODE										
TEMP (F) AIR ENT CONDENSER (Edb)		AIR ENTERING EVAPORATOR – Ewb (F)								
		75 Dry Bulb 62.5 Wet Bulb (50% Relative)			75 Dry Bulb 64 Wet Bulb (56% Relative)			75 Dry Bulb 65.3 Wet Bulb (60% Relative)		
		Air Entering Evaporator – Cfm								
		2550	3400	4250	2550	3400	4250	2550	3400	4250
80	TC	37.61	33.13	26.77	44.74	41.60	36.46	50.96	48.99	44.93
	SHC	-0.52	-0.63	-0.73	-0.46	-0.57	-0.67	-0.42	-0.53	-0.62
	kW	5.88	5.68	5.44	6.13	5.97	5.76	6.35	6.24	6.06
75	TC	38.71	34.24	27.86	45.84	42.73	37.59	52.05	50.11	46.06
	SHC	0.45	0.34	0.25	0.50	0.40	0.31	0.54	0.44	0.36
	kW	5.68	5.47	5.22	5.94	5.78	5.56	6.18	6.07	5.88
70	TC	39.70	35.25	28.83	46.80	43.70	38.59	52.97	51.04	47.02
	SHC	1.41	1.32	1.23	1.47	1.37	1.29	1.50	1.41	1.34
	kW	5.65	5.42	5.24	5.97	5.79	5.53	6.26	6.13	5.91
60	TC	41.77	37.33	30.76	48.86	45.80	40.71	55.00	53.10	49.12
	SHC	3.34	3.26	3.18	3.40	3.32	3.25	3.43	3.36	3.29
	kW	5.42	5.15	5.17	5.80	5.59	5.30	6.16	6.01	5.75
50	TC	43.83	39.27	32.61	50.92	47.89	42.70	57.04	55.16	51.22
	SHC	5.27	5.21	5.14	5.32	5.27	5.21	5.36	5.31	5.25
	kW	5.18	5.15	5.17	5.62	5.39	5.05	6.04	5.87	5.59
40	TC	45.75	41.13	34.50	53.08	50.00	44.64	59.24	57.40	53.44
	SHC	7.20	7.15	6.95	7.26	7.21	7.16	7.29	7.25	7.21
	kW	4.79	4.98	4.80	5.25	5.01	5.23	5.68	5.51	5.21

LEGEND

- Edb** – Entering Dry–Bulb
- Ewb** – Entering Wet–Bulb
- kW** – Compressor Motor Power Input
- ldb** – Leaving Dry–Bulb
- lwb** – Leaving Wet–Bulb
- SHC** – Sensible Heat Capacity (1000 Btuh) Gross
- TC** – Total Capacity (1000 Btuh) Gross

NOTES:

1. Direct interpolation is permissible. Do not extrapolate.
2. The following formulas may be used:

$$t_{ldb} = t_{edb} - \frac{\text{sensible capacity (Btuh)}}{1.10 \times \text{cfm}}$$

t_{lwb} = Wet–bulb temperature corresponding to enthalpy of air leaving evaporator coil (h_{lwb})

$$h_{lwb} = h_{ewb} - \frac{\text{total capacity (Btuh)}}{4.5 \times \text{cfm}}$$

Where: h_{ewb} = Enthalpy of air entering evaporator coil

Table 6 - COOLING CAPACITIES (cont.)

1-STAGE COOLING

10 TONS

50TC*A12 (RTPF)			AMBIENT TEMPERATURE												
			85			95			105			115			
			EAT (db)			EAT (db)			EAT (db)			EAT (db)			
			75	80	85	75	80	85	75	80	85	75	80	85	
3000 Cfm	EAT (wb)	58	TC	106.3	106.3	120.5	101.7	101.7	115.2	96.6	96.6	109.4	91.0	91.0	103.1
			SHC	92.2	106.3	120.5	88.2	101.7	115.2	83.8	96.6	109.4	78.9	91.0	103.1
		62	TC	112.5	112.5	115.2	106.5	106.5	112.3	99.9	99.9	109.0	92.7	92.7	105.2
			SHC	83.8	99.5	115.2	81.0	96.6	112.3	77.8	93.4	109.0	74.2	89.7	105.2
		67	TC	123.5	123.5	123.5	117.8	117.8	117.8	111.3	111.3	111.3	104.0	104.0	104.0
		SHC	69.2	85.0	100.7	66.8	82.5	98.3	64.1	79.8	95.5	61.0	76.8	92.5	
		72	TC	134.3	134.3	134.3	128.5	128.5	128.5	122.0	122.0	122.0	114.7	114.7	114.7
		SHC	53.8	69.6	85.5	51.6	67.4	83.2	49.1	64.9	80.7	46.3	62.1	77.9	
		76	TC	-	142.4	142.4	-	136.3	136.3	-	129.5	129.5	-	121.8	121.8
		SHC	-	56.8	73.3	-	54.7	71.2	-	52.3	68.8	-	49.7	66.2	
3500 Cfm	EAT (wb)	58	TC	112.9	112.9	127.8	108.0	108.0	122.3	102.7	102.7	116.3	96.8	96.8	109.7
			SHC	97.9	112.9	127.8	93.6	108.0	122.3	89.0	102.7	116.3	83.9	96.8	109.7
		62	TC	116.3	116.3	126.2	110.5	110.5	123.3	103.8	103.8	119.5	97.1	97.1	114.3
			SHC	90.2	108.2	126.2	87.4	105.3	123.3	84.0	101.8	119.5	79.8	97.1	114.3
		67	TC	126.9	126.9	126.9	120.9	120.9	120.9	114.3	114.3	114.3	106.8	106.8	106.8
		SHC	73.2	91.3	109.4	70.8	88.9	107.1	68.1	86.2	104.4	65.0	83.2	101.3	
		72	TC	137.5	137.5	137.5	131.4	131.4	131.4	124.7	124.7	124.7	117.2	117.2	117.2
		SHC	55.3	73.4	91.5	53.1	71.1	89.2	50.6	68.7	86.7	47.8	65.9	83.9	
		76	TC	-	145.1	145.1	-	138.8	138.8	-	131.7	131.7	-	123.6	123.6
		SHC	-	59.0	78.2	-	56.7	75.8	-	54.3	73.1	-	51.5	70.0	
4000 Cfm	EAT (wb)	58	TC	117.8	117.8	133.5	113.0	113.0	128.0	107.5	107.5	121.8	101.5	101.5	115.0
			SHC	102.2	117.8	133.5	98.0	113.0	128.0	93.3	107.5	121.8	88.0	101.5	115.0
		62	TC	119.1	119.1	136.0	113.5	113.5	132.5	107.7	107.7	126.7	101.6	101.6	119.6
			SHC	95.8	115.9	136.0	92.8	112.6	132.5	88.6	107.7	126.7	83.6	101.6	119.6
		67	TC	129.4	129.4	129.4	123.3	123.3	123.3	116.5	116.5	116.5	108.9	108.9	109.8
		SHC	76.9	97.3	117.7	74.5	95.0	115.4	71.8	92.3	112.8	68.8	89.3	109.8	
		72	TC	139.7	139.7	139.7	133.5	133.5	133.5	126.6	126.6	126.6	118.8	118.8	118.8
		SHC	56.7	76.8	97.0	54.4	74.6	94.7	51.9	72.1	92.3	49.1	69.3	89.5	
		76	TC	-	147.0	147.0	-	140.5	140.5	-	133.2	133.2	-	124.9	124.9
		SHC	-	60.6	81.7	-	58.4	79.3	-	55.8	76.5	-	53.0	73.5	
4500 Cfm	EAT (wb)	58	TC	121.7	121.7	137.9	116.8	116.8	132.3	111.2	111.2	126.0	105.0	105.0	118.9
			SHC	105.6	121.7	137.9	101.3	116.8	132.3	96.4	111.2	126.0	91.0	105.0	118.9
		62	TC	121.8	121.8	143.4	116.9	116.9	137.6	111.3	111.3	131.0	105.1	105.1	123.7
			SHC	100.2	121.8	143.4	96.1	116.9	137.6	91.6	111.3	131.0	86.5	105.1	123.7
		67	TC	131.3	131.3	131.3	125.1	125.1	125.1	118.2	118.2	120.8	110.5	110.5	117.7
		SHC	80.3	102.9	125.5	78.0	100.7	123.3	75.3	98.0	120.8	72.3	95.0	117.7	
		72	TC	141.5	141.5	141.5	135.1	135.1	135.1	128.0	128.0	128.0	120.1	120.1	120.1
		SHC	57.9	80.0	102.1	55.6	77.7	99.9	53.1	75.2	97.4	50.3	72.4	94.6	
		76	TC	-	148.3	148.3	-	141.8	141.8	-	134.3	134.3	-	125.8	125.8
		SHC	-	62.1	84.9	-	59.8	82.5	-	57.3	79.7	-	54.4	76.6	
5000 Cfm	EAT (wb)	58	TC	125.0	125.0	141.6	120.0	120.0	135.9	114.3	114.3	129.5	107.9	107.9	122.3
			SHC	108.4	125.0	141.6	104.0	120.0	135.9	99.1	114.3	129.5	93.6	107.9	122.3
		62	TC	125.1	125.1	147.2	120.1	120.1	141.4	114.4	114.4	134.7	108.0	108.0	127.2
			SHC	102.9	125.1	147.2	98.8	120.1	141.4	94.1	114.4	134.7	88.9	108.0	127.2
		67	TC	132.8	132.8	133.0	126.5	126.5	130.8	119.6	119.6	128.2	111.8	111.8	125.1
		SHC	83.6	108.3	133.0	81.2	106.0	130.8	78.6	103.4	128.2	75.6	100.3	125.1	
		72	TC	142.8	142.8	142.8	136.3	136.3	136.3	129.1	129.1	129.1	121.1	121.1	121.1
		SHC	59.0	82.9	106.9	56.7	80.7	104.7	54.1	78.2	102.2	51.3	75.4	99.4	
		76	TC	-	149.4	149.4	-	142.8	142.8	-	135.1	135.1	-	126.5	126.5
		SHC	-	63.4	87.9	-	61.2	85.5	-	58.6	82.7	-	55.6	79.4	

LEGEND:

- Do not operate in this region
- Cfm - Cubic feet per minute (supply air)
- EAT(db) - Entering air temperature (dry bulb)
- EAT(wb) - Entering air temperature (wet bulb)
- SHC - Sensible heat capacity
- TC - Total capacity

Table 6 - COOLING CAPACITIES (cont.)

2-STAGE COOLING

10 TONS

50TC*D12 (RTPF & Novation)			AMBIENT TEMPERATURE												
			85			95			105			115			
			EAT (db)			EAT (db)			EAT (db)			EAT (db)			
			75	80	85	75	80	85	75	80	85	75	80	85	
3000 Cfm	EAT (wb)	58	TC	107.6	107.6	121.9	102.5	102.5	116.2	96.8	96.8	109.7	90.5	90.5	102.6
			SHC	93.2	107.6	121.9	88.8	102.5	116.2	83.9	96.8	109.7	78.4	90.5	102.6
		62	TC	113.6	113.6	116.5	107.1	107.1	113.4	99.7	99.7	109.8	91.8	91.8	104.9
			SHC	84.6	100.6	116.5	81.5	97.4	113.4	78.0	93.9	109.8	73.7	89.3	104.9
		67	TC	124.4	124.4	124.4	118.4	118.4	118.4	111.5	111.5	111.5	103.3	103.3	103.3
	SHC		69.7	85.7	101.7	67.1	83.2	99.2	64.3	80.3	96.3	60.8	76.8	92.8	
	72	TC	135.8	135.8	135.8	129.7	129.7	129.7	122.8	122.8	122.8	115	115	115	
		SHC	54.3	70.4	86.6	52.0	68.1	84.2	49.3	65.4	81.6	46.4	62.5	78.6	
	76	TC	-	145.3	145.3	-	139	139	-	131.9	131.9	-	124.1	124.1	
		SHC	-	57.8	74.3	-	55.6	72.1	-	53.1	69.6	-	50.4	66.9	
3500 Cfm	EAT (wb)	58	TC	114.2	114.2	129.4	108.9	108.9	123.4	102.9	102.9	116.6	96.3	96.3	109.1
			SHC	98.9	114.2	129.4	94.3	108.9	123.4	89.1	102.9	116.6	83.4	96.3	109.1
		62	TC	117.2	117.2	127.9	111.0	111.0	124.7	104.0	104.0	119.5	96.5	96.5	113.7
			SHC	91.1	109.5	127.9	88.1	106.4	124.7	83.9	101.7	119.5	79.3	96.5	113.7
		67	TC	127.8	127.8	127.8	121.7	121.7	121.7	114.5	114.5	114.5	106.6	106.6	106.6
	SHC		73.8	92.3	110.8	71.3	89.8	108.3	68.4	87.0	105.5	65.2	83.8	102.3	
	72	TC	139.4	139.4	139.4	133.0	133.0	133	125.8	125.8	125.8	117.9	117.9	117.9	
		SHC	56.0	74.6	93.1	53.7	72.2	90.8	51.0	69.6	88.2	48.1	66.7	85.4	
	76	TC	-	148.8	148.8	-	142.2	142.2	-	134.9	134.9	-	126.8	126.8	
		SHC	-	60.2	79.5	-	58.0	77.1	-	55.4	74.5	-	52.7	71.6	
4000 Cfm	EAT (wb)	58	TC	119.0	119.0	134.9	114.0	114.0	129.2	108.0	108.0	122.4	101.1	101.1	114.6
			SHC	103.1	119.0	134.9	98.7	114.0	129.2	93.6	108.0	122.4	87.6	101.1	114.6
		62	TC	120.3	120.3	137.1	114.7	114.7	132.8	108.2	108.2	127.5	101.3	101.3	119.3
			SHC	96.5	116.8	137.1	93.0	112.9	132.8	88.9	108.2	127.5	83.2	101.3	119.3
		67	TC	130.5	130.5	130.5	124.1	124.1	124.1	116.8	116.8	116.8	108.7	108.7	111.1
	SHC		77.7	98.6	119.5	75.2	96.2	117.2	72.3	93.3	114.4	69.1	90.1	111.1	
	72	TC	142.1	142.1	142.1	135.5	135.5	135.5	128.2	128.2	128.2	120.0	120.0	120.0	
		SHC	57.6	78.4	99.3	55.2	76.1	97.1	52.5	73.6	94.6	49.7	70.7	91.8	
	76	TC	-	151.4	151.4	-	144.7	144.7	-	137.1	137.1	-	-	-	
		SHC	-	62.3	83.8	-	60.0	81.4	-	57.5	78.8	-	-	-	
4500 Cfm	EAT (wb)	58	TC	123.0	123.0	139.5	117.8	117.8	133.6	111.9	111.9	126.9	105.3	105.3	119.3
			SHC	106.6	123.0	139.5	102.1	117.8	133.6	97.0	111.9	126.9	91.2	105.3	119.3
		62	TC	123.4	123.4	144.4	117.9	117.9	139.0	112.0	112.0	132.0	105.4	105.4	124.2
			SHC	100.9	122.7	144.4	96.9	117.9	139	92.1	112.0	132	86.6	105.4	124.2
		67	TC	132.6	132.6	132.6	126.0	126	126.0	118.7	118.7	122.9	110.4	110.4	119.6
	SHC		81.4	104.6	127.9	78.9	102.3	125.7	76.1	99.5	122.9	72.9	96.2	119.6	
	72	TC	144.2	144.2	144.2	137.4	137.4	137.4	129.9	129.9	129.9	121.6	121.6	121.6	
		SHC	59.0	82.1	105.2	56.6	79.8	103.1	54.0	77.3	100.7	51.1	74.5	98	
	76	TC	-	153.4	153.4	-	146.6	146.6	-	138.9	138.9	-	-	-	
		SHC	-	64.1	87.8	-	61.9	85.6	-	59.4	83	-	-	-	
5000 Cfm	EAT (wb)	58	TC	126.5	126.5	143.3	121.2	121.2	137.4	115.1	115.1	130.5	108.4	108.4	122.8
			SHC	109.6	126.5	143.3	105.0	121.2	137.4	99.8	115.1	130.5	93.9	108.4	122.8
		62	TC	126.5	126.5	149.1	121.3	121.3	142.9	115.2	115.2	135.8	108.5	108.5	127.8
			SHC	104.0	126.5	149.1	99.7	121.3	142.9	94.7	115.2	135.8	89.1	108.5	127.8
		67	TC	134.2	134.2	135.9	127.5	127.5	133.8	120.1	120.1	131.0	111.9	111.9	127.6
	SHC		84.9	110.4	135.9	82.4	108.1	133.8	79.6	105.3	131	76.4	102.0	127.6	
	72	TC	145.8	145.8	145.8	139.0	139.0	139.0	131.3	131.3	131.3	122.9	122.9	122.9	
		SHC	60.3	85.6	110.8	57.9	83.4	108.9	55.3	81.0	106.6	52.5	78.2	104	
	76	TC	-	155.1	155.1	-	148.2	148.2	-	-	-	-	-	-	
		SHC	-	65.9	91.5	-	63.7	89.5	-	-	-	-	-	-	

* See Minimum–Maximum Airflow Ratings in Table 3. Do not operate outside these limits.

LEGEND:

- Do not operate in this region
- Cfm - Cubic feet per minute (supply air)
- EAT(db) - Entering air temperature (dry bulb)
- EAT(wb) - Entering air temperature (wet bulb)
- SHC - Sensible heat capacity
- TC - Total capacity

50TC12 COOLING CAPACITIES, UNIT WITH HUMIDI-MIZER SYSTEM IN SUBCOOLING MODE										
TEMP (F) AIR ENT CONDENSER (Edb)		AIR ENTERING EVAPORATOR – CFM								
		3000/0.04			4000/0.06			5000/0.07		
		Air Entering Evaporator – Ewb (F)								
		72	67	62	72	67	62	72	67	62
75	TC	142.85	129.44	116.93	152.09	138.44	125.76	157.99	144.23	132.06
	SHC	58.38	74.88	91.58	67.96	89.45	111.02	76.63	102.94	127.93
	kW	7.19	6.97	6.79	6.92	7.12	7.35	7.45	7.22	7.02
85	TC	132.33	119.68	107.86	140.92	128.03	116.10	146.41	133.41	121.98
	SHC	48.44	65.56	82.83	57.37	79.50	101.68	65.65	92.58	118.12
	kW	7.98	7.77	7.58	7.72	7.92	8.14	8.25	8.01	7.82
95	TC	121.41	109.52	98.43	129.35	117.22	106.04	134.43	122.20	111.50
	SHC	38.19	55.92	73.78	46.47	69.22	92.01	54.34	81.92	107.96
	kW	8.87	8.66	8.48	8.61	8.80	9.03	9.14	8.90	8.71
105	TC	110.04	98.92	88.56	117.27	105.94	95.53	121.88	110.46	100.54
	SHC	27.59	45.94	64.39	35.16	58.57	81.98	42.56	70.82	97.40
	kW	9.86	9.66	9.48	9.61	9.79	10.02	10.12	9.89	9.70
115	TC	98.09	87.74	78.13	104.62	94.08	84.45	108.76	98.13	89.01
	SHC	16.52	35.47	54.53	23.37	47.44	71.46	30.32	59.25	86.31
	kW	10.95	10.76	10.60	10.72	10.89	11.10	11.19	10.98	10.81

50TC12 COOLING CAPACITIES, UNIT WITH HUMIDI-MIZER SYSTEM IN HOT GAS REHEAT MODE										
TEMP (F) AIR ENT CONDENSER (Edb)		AIR ENTERING EVAPORATOR – Ewb (F)								
		75 Dry Bulb 62.5 Wet Bulb (50% Relative)			75 Dry Bulb 64 Wet Bulb (56% Relative)			75 Dry Bulb 65.3 Wet Bulb (60% Relative)		
		Air Entering Evaporator – Cfm								
		3000	4000	5000	3000	4000	5000	3000	4000	5000
80	TC	44.78	39.41	31.89	53.22	49.44	43.38	60.56	58.12	53.32
	SHC	-0.44	-0.57	-0.69	-0.37	-0.51	-0.61	-0.33	-0.46	-0.56
	kW	6.96	6.77	6.52	7.26	7.13	6.91	7.54	7.45	7.27
75	TC	45.84	40.46	32.86	54.28	50.51	44.45	61.61	59.19	54.40
	SHC	0.53	0.40	0.29	0.60	0.47	0.37	0.64	0.52	0.42
	kW	6.77	6.56	6.29	7.11	6.95	6.72	7.41	7.31	7.12
70	TC	46.91	41.48	33.50	55.36	51.59	45.50	62.69	60.28	55.49
	SHC	1.51	1.38	1.27	1.57	1.45	1.35	1.61	1.50	1.40
	kW	6.54	6.32	6.02	6.90	6.74	6.49	7.23	7.13	6.92
60	TC	48.88	43.42	35.76	57.29	53.56	47.48	64.56	62.16	57.42
	SHC	3.44	3.34	3.24	3.51	3.40	3.31	3.55	3.45	3.37
	kW	6.45	6.16	6.70	6.93	6.72	6.39	7.38	7.24	6.96
50	TC	50.83	45.28	37.67	59.22	55.52	49.43	66.05	64.03	59.34
	SHC	5.38	5.29	5.20	5.45	5.36	5.28	5.48	5.40	5.33
	kW	6.46	6.01	6.34	6.98	6.71	6.29	8.15	7.38	7.02
40	TC	52.82	47.29	39.50	61.14	57.48	51.39	68.23	65.88	61.25
	SHC	7.32	7.24	7.20	7.38	7.31	7.24	7.43	7.36	7.29
	kW	6.29	6.09	6.12	7.05	6.72	6.29	7.78	7.55	7.10

LEGEND

- Edb** – Entering Dry-Bulb
- Ewb** – Entering Wet-Bulb
- kW** – Compressor Motor Power Input
- ldb** – Leaving Dry-Bulb
- lwb** – Leaving Wet-Bulb
- SHC** – Sensible Heat Capacity (1000 Btuh) Gross
- TC** – Total Capacity (1000 Btuh) Gross

NOTES:

1. Direct interpolation is permissible. Do not extrapolate.
2. The following formulas may be used:

$$t_{ldb} = t_{edb} - \frac{\text{sensible capacity (Btuh)}}{1.10 \times \text{cfm}}$$

$$t_{lwb} = \text{Wet-bulb temperature corresponding to enthalpy of air leaving evaporator coil } (h_{lwb})$$

$$h_{lwb} = h_{ewb} - \frac{\text{total capacity (Btuh)}}{4.5 \times \text{cfm}}$$

Where: h_{ewb} = Enthalpy of air entering evaporator coil

Table 6 - COOLING CAPACITIES (cont.)

2-STAGE COOLING

12.5 TONS

50TC*D14 (RTPF & Novation)			AMBIENT TEMPERATURE												
			85			95			105			115			
			EAT (db)			EAT (db)			EAT (db)			EAT (db)			
			75	80	85	75	80	85	75	80	85	75	80	85	
3600 Cfm	EAT (wb)	58	TC	127.6	127.6	142.9	121.7	121.7	137.6	115.0	115.0	130	108.3	108.3	122.6
			SHC	110.3	126.6	142.9	105.8	121.7	137.6	99.9	115.0	130	94.1	108.3	122.6
		62	TC	136.1	136.1	136.1	131.1	131.1	131.1	123.8	123.8	124.5	114.9	114.9	120.3
			SHC	96.6	112.8	129.0	94.7	111.2	127.7	91.4	108.0	124.5	87.3	103.8	120.3
		67	TC	146.2	146.2	146.2	142.0	142.0	142.0	136.2	136.2	136.2	128.8	128.8	128.8
		SHC	78.5	94.4	110.3	76.9	93.1	109.2	74.7	91.0	107.3	71.7	88.1	104.6	
	72	TC	155.9	155.9	155.9	152.4	152.4	152.4	147.2	147.2	147.2	140.1	140.1	140.1	
		SHC	60.1	76.6	93.2	58.7	75.2	91.7	56.8	73.3	89.7	54.2	70.6	87.0	
	76	TC	-	163.0	163	-	160.0	160	-	155.1	155.1	-	148.2	148.2	
		SHC	-	62.0	81.8	-	61.1	80.9	-	59.5	79.3	-	57.0	76.3	
4200 Cfm	EAT (wb)	58	TC	132.2	132.2	149.5	128.2	128.2	144.9	121.9	121.9	137.8	115.0	115.0	130.1
			SHC	115.0	132.2	149.5	111.5	128.2	144.9	106.0	121.9	137.8	99.9	115.0	130.1
		62	TC	139.6	139.6	139.6	134.7	134.7	138	128.0	128.0	135.6	119.1	119.1	131.2
			SHC	102.5	120.8	139	100.8	119.4	138	98.1	116.8	135.6	93.9	112.6	131.2
		67	TC	149.5	149.5	149.5	145.4	145.4	145.4	139.6	139.6	139.6	132.1	132.1	132.1
		SHC	81.8	99.6	117.4	80.6	98.7	116.8	78.5	96.9	115.2	75.7	94.3	112.8	
	72	TC	159.0	159.0	159.0	155.5	155.5	155.5	150.3	150.3	150.3	143.1	143.1	143.1	
		SHC	61.4	79.6	97.8	60.2	78.5	96.8	58.3	76.7	95	55.8	74.2	92.5	
	76	TC	-	165.7	165.7	-	162.8	162.8	-	157.8	157.8	-	150.8	150.8	
		SHC	-	64.6	87.7	-	63.5	86.3	-	61.5	83.3	-	58.9	79.9	
4800 Cfm	EAT (wb)	58	TC	136.7	136.7	154.5	133.0	133.0	150.3	127.7	127.7	144.3	120.6	120.6	136.4
			SHC	118.9	136.7	154.5	115.7	133.0	150.3	111.0	127.7	144.3	104.9	120.6	136.4
		62	TC	142.2	142.2	147.8	137.4	137.4	147.1	131.0	131.0	144.7	122.8	122.8	140.3
			SHC	107.7	127.8	147.8	106.2	126.7	147.1	103.6	124.2	144.7	99.3	119.8	140.3
		67	TC	152.1	152.1	152.1	148.0	148	148	142.2	142.2	142.2	134.6	134.6	134.6
		SHC	84.8	104.3	123.7	83.8	103.8	123.7	82.0	102.3	122.6	79.4	99.9	120.4	
	72	TC	161.3	161.3	161.3	157.8	157.8	157.8	152.5	152.5	152.5	145.4	145.4	145.4	
		SHC	62.6	82.2	101.9	61.4	81.4	101.3	59.7	79.7	99.8	57.2	77.3	97.5	
	76	TC	-	167.7	167.7	-	164.9	164.9	-	159.9	159.9	-	152.8	152.8	
		SHC	-	66.4	91.4	-	65	89.2	-	63.1	86.4	-	60.5	83.1	
5400 Cfm	EAT (wb)	58	TC	140.5	140.5	158.8	136.9	136.9	154.7	131.8	131.8	149	125.2	125.2	141.6
			SHC	122.2	140.5	158.8	119	136.9	154.7	114.7	131.8	149	108.9	125.2	141.6
		62	TC	144.3	144.3	155.7	139.6	139.6	155	133.5	133.5	152.4	125.8	125.8	147.8
			SHC	112.2	133.9	155.7	110.9	132.9	155	108.1	130.2	152.4	103.9	125.8	147.8
		67	TC	154.2	154.2	154.2	150.0	150.0	150.0	144.2	144.2	144.2	136.7	136.7	136.7
		SHC	87.6	108.6	129.6	86.8	108.5	130.1	85.2	107.3	129.4	82.8	105.1	127.4	
	72	TC	163.1	163.1	163.1	159.7	159.7	159.7	154.3	154.3	154.3	147.1	147.1	147.1	
		SHC	63.6	84.6	105.6	62.5	83.9	105.4	60.8	82.5	104.2	58.4	80.2	102	
	76	TC	-	169.3	169.3	-	166.5	166.5	-	161.5	161.5	-	154.2	154.2	
		SHC	-	67.6	93.7	-	66.4	91.7	-	64.5	89.2	-	61.9	86.1	
6000 Cfm	EAT (wb)	58	TC	143.6	143.6	162.3	140.1	140.1	158.3	135.1	135.1	152.7	128.7	128.7	145.5
			SHC	124.9	143.6	162.3	121.8	140.1	158.3	117.5	135.1	152.7	111.9	128.7	145.5
		62	TC	146.1	146.1	162.4	141.7	141.7	161.5	135.6	135.6	159.2	128.8	128.8	151.2
			SHC	116.1	139.3	162.4	114.7	138.1	161.5	112.1	135.6	159.2	106.4	128.8	151.2
		67	TC	155.8	155.8	155.8	151.6	151.6	151.6	145.9	145.9	145.9	138.3	138.3	138.3
		SHC	90.1	112.6	135	89.6	112.8	136	88.3	112.0	135.8	85.9	110.0	134.1	
	72	TC	164.5	164.5	164.5	161.2	161.2	161.2	155.8	155.8	155.8	148.5	148.5	148.5	
		SHC	64.5	86.7	108.9	63.5	86.3	109.1	61.9	85.1	108.2	59.6	82.9	106.3	
	76	TC	-	170.6	170.6	-	167.8	167.8	-	162.8	162.8	-	155.5	155.5	
		SHC	-	68.7	95.8	-	67.5	94.1	-	65.7	91.8	-	63.3	88.8	

* See Minimum–Maximum Airflow Ratings in Table 3. Do not operate outside these limits.

LEGEND:

- Do not operate in this region
- Cfm - Cubic feet per minute (supply air)
- EAT(db) - Entering air temperature (dry bulb)
- EAT(wb) - Entering air temperature (wet bulb)
- SHC - Sensible heat capacity
- TC - Total capacity

Table 6 - COOLING CAPACITIES (cont.) 2-STAGE COOLING

12.5 TONS

50TC14 COOLING CAPACITIES, UNIT WITH HUMIDI-MIZER SYSTEM IN SUBCOOLING MODE										
TEMP (F) AIR ENT CONDENSER (Edb)		AIR ENTERING EVAPORATOR – CFM								
		3750/0.02			5000/0.06			6250/0.05		
		Air Entering Evaporator – Ewb (F)								
		72	67	62	72	67	62	72	67	62
75	TC	183.66	166.86	151.43	194.90	177.83	162.05	201.97	184.84	170.53
	SHC	79.39	100.52	121.91	91.70	119.42	147.05	102.94	137.00	166.71
	kW	9.82	9.63	9.46	9.58	9.76	9.96	10.04	9.84	9.67
85	TC	172.71	156.78	142.09	183.32	167.13	152.17	189.98	173.73	160.25
	SHC	69.03	90.92	112.95	80.69	109.17	137.51	91.49	126.33	156.65
	kW	10.82	10.63	10.45	10.57	10.76	10.96	11.04	10.84	10.67
95	TC	161.37	146.24	132.38	171.36	156.04	141.86	177.62	162.22	149.50
	SHC	58.44	81.04	103.77	69.42	98.67	127.71	79.83	115.45	146.15
	kW	11.92	11.73	11.56	11.68	11.86	12.05	12.14	11.93	11.77
105	TC	149.57	135.32	122.21	158.89	144.45	131.10	164.74	150.27	138.35
	SHC	47.57	70.92	94.32	57.85	87.91	117.61	67.79	104.26	135.30
	kW	13.12	12.94	12.77	12.89	13.06	13.24	13.32	13.13	12.97
115	TC	137.22	123.88	111.55	145.85	132.33	119.84	151.27	137.71	126.67
	SHC	36.31	60.47	84.57	45.87	76.77	107.19	55.34	92.66	123.98
	kW	14.41	14.25	14.10	14.20	14.35	14.53	14.59	14.42	14.28

50 TC14 COOLING CAPACITIES, UNIT WITH HUMIDI-MIZER SYSTEM IN HOT GAS REHEAT MODE										
TEMP (F) AIR ENT CONDENSER (Edb)		AIR ENTERING EVAPORATOR – Ewb (F)								
		75 Dry Bulb 62.5 Wet Bulb (50% Relative)			75 Dry Bulb 64 Wet Bulb (56% Relative)			75 Dry Bulb 65.3 Wet Bulb (60% Relative)		
		Air Entering Evaporator – Cfm								
		3750	5000	6250	3750	5000	6250	3750	5000	6250
80	TC	52.42	45.88	36.99	62.64	58.07	51.07	71.56	68.64	63.23
	SHC	-0.39	-0.54	-0.67	-0.31	-0.46	-0.58	-0.26	-0.40	-0.52
	kW	9.65	9.39	9.07	9.97	9.77	9.50	10.25	10.11	9.89
75	TC	53.45	46.63	36.10	63.77	59.11	51.87	72.76	69.80	64.31
	SHC	0.59	0.44	0.30	0.67	0.52	0.40	0.72	0.58	0.47
	kW	9.09	8.83	8.49	9.39	9.20	8.94	9.67	9.53	9.32
70	TC	54.33	46.91	37.58	64.77	60.01	52.30	73.80	70.80	65.24
	SHC	1.56	1.41	1.29	1.64	1.50	1.38	1.70	1.56	1.45
	kW	8.81	8.53	8.62	9.15	8.94	8.65	9.46	9.31	9.08
60	TC	55.47	49.48	40.48	66.62	62.07	54.88	75.68	72.76	67.28
	SHC	3.50	3.38	3.27	3.59	3.47	3.36	3.65	3.52	3.42
	kW	8.36	8.84	8.98	9.88	9.56	9.10	9.83	9.64	9.31
50	TC	58.33	51.72	42.81	68.72	63.93	55.84	77.74	74.77	69.24
	SHC	5.47	5.35	5.24	5.54	5.43	5.32	5.60	5.49	5.39
	kW	8.98	9.25	9.43	9.33	8.97	8.73	9.55	9.33	9.70
40	TC	60.33	53.69	46.89	70.67	65.93	49.83	79.46	76.62	71.24
	SHC	7.42	7.31	7.22	7.49	7.39	7.23	7.55	7.45	7.37
	kW	9.16	9.88	9.06	9.50	9.05	9.47	10.31	10.00	9.48

LEGEND

- Edb** – Entering Dry–Bulb
- Ewb** – Entering Wet–Bulb
- kW** – Compressor Motor Power Input
- ldb** – Leaving Dry–Bulb
- lwb** – Leaving Wet–Bulb
- SHC** – Sensible Heat Capacity (1000 Btuh) Gross
- TC** – Total Capacity (1000 Btuh) Gross

50TC*D16 (RTPF)			Ambient Temperature												
			85			95			105			115			
			EA (dB)			EA (dB)			EA (dB)			EA (dB)			
			75	80	85	75	80	85	75	80	85	75	80	85	
4500 Cfm	EAT (wb)	58	THC	156.6	156.6	175.2	149.4	149.4	169.1	141.6	141.6	160.2	133.3	133.3	150.9
			SHC	134.7	154.9	175.2	129.8	149.4	169.1	123.0	141.6	160.2	115.7	133.3	150.9
		62	THC	166.7	166.7	166.9	158.0	158.0	162.6	147.6	147.6	157.2	136.8	136.8	150.3
			SHC	122.8	144.9	166.9	118.6	140.6	162.6	113.5	135.3	157.2	107.4	128.8	150.3
		67	THC	184.1	184.1	184.1	175.6	175.6	175.6	165.6	165.6	165.6	154.5	154.5	154.5
	SHC		101.6	123.7	145.7	98.1	120.2	142.3	94.0	116.1	138.2	89.4	111.5	133.6	
	72	THC	200.3	200.3	200.3	192.0	192.0	192.0	182.9	182.9	182.9	172.2	172.2	172.2	
		SHC	78.7	101.1	123.5	75.5	97.9	120.2	72.1	94.4	116.7	68.2	90.5	112.7	
	76	THC	-	211.4	211.4	-	203.1	203.1	-	193.8	193.8	-	183.9	183.9	
		SHC	-	82.2	107.0	-	79.3	103.8	-	76.0	100.2	-	72.6	96.5	
5250 Cfm	EAT (wb)	58	THC	165.2	165.2	186.9	158.2	158.2	179.0	150.0	150.0	169.7	141.3	141.3	160.0
			SHC	143.5	165.2	186.9	137.4	158.2	179.0	130.2	150.0	169.7	122.7	141.3	160.0
		62	THC	172.3	172.3	181.7	163.4	163.4	176.9	153.1	153.1	169.3	143.4	143.4	161.4
			SHC	131.6	156.6	181.7	127.1	152.0	176.9	120.5	144.9	169.3	114.1	137.8	161.4
		67	THC	189.5	189.5	189.5	180.9	180.9	180.9	170.7	170.7	170.7	159.1	159.1	159.1
	SHC		107.2	132.4	157.5	103.8	129.0	154.1	99.9	125.1	150.4	95.3	120.6	145.8	
	72	THC	205.0	205.0	205.0	196.5	196.5	196.5	187.1	187.1	187.1	176.4	176.4	176.4	
		SHC	80.9	106.1	131.3	77.7	102.9	128.1	74.4	99.5	124.7	70.6	95.8	121.0	
	76	THC	-	215.4	215.4	-	206.8	206.8	-	197.1	197.1	-	186.9	186.9	
		SHC	-	85.0	113.0	-	82.0	109.8	-	78.8	106.4	-	75.4	102.8	
6000 Cfm	EAT (wb)	58	THC	172.7	172.7	195.4	165.5	165.5	187.3	157.1	157.1	177.8	148.1	148.1	167.7
			SHC	150.0	172.7	195.4	143.8	165.5	187.3	136.4	157.1	177.8	128.6	148.1	167.7
		62	THC	176.6	176.6	195.7	168.1	168.1	187.6	158.9	158.9	180.2	148.9	148.9	172.1
			SHC	139.6	167.7	195.7	133.2	160.4	187.6	127.1	153.7	180.2	120.7	146.4	172.1
		67	THC	193.6	193.6	193.6	184.8	184.8	184.8	174.7	174.7	174.7	162.7	162.7	162.7
	SHC		112.3	140.3	168.3	108.9	137.0	165.2	105.2	133.5	161.7	100.7	129.0	157.3	
	72	THC	208.4	208.4	208.4	199.6	199.6	199.6	190.2	190.2	190.2	179.5	179.5	179.5	
		SHC	82.7	110.5	138.3	79.6	107.3	135.1	76.2	104.0	131.8	72.6	100.6	128.5	
	76	THC	-	218.2	218.2	-	209.5	209.5	-	199.5	199.5	-	189.0	189.0	
		SHC	-	87.5	118.6	-	84.5	115.2	-	81.1	111.3	-	77.5	107.3	
6750 Cfm	EAT (wb)	58	THC	178.8	178.8	202.4	171.6	171.6	194.2	163.1	163.1	184.6	153.8	153.8	174.1
			SHC	155.3	178.8	202.4	149.0	171.6	194.2	141.6	163.1	184.6	133.5	153.8	174.1
		62	THC	181.0	181.0	203.6	173.0	173.0	197.5	163.8	163.8	190.1	153.9	153.9	181.1
			SHC	144.1	173.9	203.6	139.1	168.3	197.5	133.3	161.7	190.1	126.7	153.9	181.1
		67	THC	196.8	196.8	196.8	187.9	187.9	187.9	177.7	177.7	177.7	165.5	165.5	167.9
	SHC		117.0	147.7	178.4	113.7	144.5	175.4	110.1	141.1	172.2	105.6	136.8	167.9	
	72	THC	211.0	211.0	211.0	202.2	202.2	202.2	192.5	192.5	192.5	181.8	181.8	181.8	
		SHC	84.3	114.5	144.7	81.2	111.5	141.7	77.9	108.1	138.4	74.4	104.9	135.4	
	76	THC	-	220.2	220.2	-	211.5	211.5	-	201.3	201.3	-	190.6	190.6	
		SHC	-	89.5	122.8	-	86.4	119.4	-	83.0	115.4	-	79.4	111.5	
7500 Cfm	EAT (wb)	58	THC	183.9	183.9	208.2	176.6	176.6	199.8	168.2	168.2	190.3	158.6	158.6	179.5
			SHC	159.7	183.9	208.2	153.3	176.6	199.8	146.0	168.2	190.3	137.7	158.6	179.5
		62	THC	185.1	185.1	212.5	177.1	177.1	206.2	168.3	168.3	197.9	158.7	158.7	186.7
			SHC	149.5	181.0	212.5	144.5	175.4	206.2	138.7	168.3	197.9	130.8	158.7	186.7
		67	THC	199.3	199.3	199.3	190.3	190.3	190.3	180.0	180.0	181.7	167.8	167.8	177.8
	SHC		121.3	154.6	187.9	118.1	151.6	185.1	114.4	148.1	181.7	110.1	144.0	177.8	
	72	THC	213.0	213.0	213.0	204.1	204.1	204.1	194.2	194.2	194.2	183.5	183.5	183.5	
		SHC	85.8	118.2	150.5	82.7	115.2	147.7	79.4	111.9	144.4	76.0	108.8	141.6	
	76	THC	-	221.9	221.9	-	213.0	213.0	-	202.7	202.7	-	191.8	191.8	
		SHC	-	91.2	126.5	-	88.2	123.1	-	84.7	119.2	-	81.2	115.3	

* See Minimum–Maximum Airflow Ratings in Table 3. Do not operate outside these limits.

LEGEND:

- Do not operate in this region
- Cfm - Cubic feet per minute (supply air)
- EAT(db) - Entering air temperature (dry bulb)
- EAT(wb) - Entering air temperature (wet bulb)
- SHC - Sensible heat capacity
- TC - Total capacity

50TC*E16 Cooling Capacities, Subcooling Mode										
TEMP (F) AIR ENT CONDENSER (Edb)		AIR ENTERING EVAPORATOR – CFM								
		4500/0.02			6000/0.06			7500/0.05		
		Air Entering Evaporator – Ewb (F)								
		72	67	62	72	67	62	72	67	62
75	TC	204.4	186.3	168.2	218.4	199.6	180.9	229.6	210.4	191.2
	SHC	98.9	118.1	137.2	114.8	133.7	152.6	127.6	146.2	164.9
	kW	11.57	11.22	10.77	11.78	11.45	11.00	12.06	11.64	11.35
85	TC	189.2	171.7	154.1	203.0	184.8	166.7	214.1	195.5	176.9
	SHC	79.5	103.4	127.3	96.5	120.2	144.0	110.2	133.7	157.3
	kW	12.59	12.24	11.81	12.81	12.50	12.03	13.05	12.66	12.47
95	TC	174.0	157.0	140.0	187.6	170.1	152.5	198.6	180.6	162.7
	SHC	60.0	88.7	117.5	78.2	106.8	135.3	92.9	121.3	149.7
	kW	13.68	13.35	12.86	13.91	13.57	13.05	14.15	13.75	13.47
105	TC	158.8	142.3	125.8	172.2	155.3	138.3	183.1	165.7	148.4
	SHC	40.5	74.1	107.7	59.9	93.3	126.7	75.5	108.8	142.0
	kW	14.67	14.41	13.88	14.90	14.55	14.10	15.15	14.73	14.53
115	TC	143.6	127.6	111.7	156.8	140.5	124.1	167.6	150.9	134.2
	SHC	21.0	59.4	97.8	41.6	79.9	118.1	58.1	96.3	134.2
	kW	15.77	15.38	14.88	15.88	15.65	15.10	16.12	15.84	15.54

50TC*E16 Cooling Capacities, Hot Gas Reheat Mode										
TEMP (F) AIR ENT CONDENSER (Edb)		AIR ENTERING EVAPORATOR – Ewb (F)								
		75 Dry Bulb 62.5 Wet Bulb (50% Relative)			75 Dry Bulb 64 Wet Bulb (56% Relative)			75 Dry Bulb 65.3 Wet Bulb (60% Relative)		
		Air Entering Evaporator – Cfm								
		4500	6000	7500	4500	6000	7500	4500	6000	7500
80	TC	83.75	84.85	88.95	86.65	91.90	92.90	87.90	91.75	96.30
	SHC	37.50	42.80	55.10	30.90	40.40	44.50	24.80	29.30	34.10
	kW	10.50	11.49	11.60	10.56	10.65	11.70	11.60	11.72	11.77
75	TC	85.00	86.00	90.50	88.05	93.60	94.65	89.20	93.45	97.85
	SHC	40.00	45.00	57.30	33.20	42.30	46.90	26.90	31.50	36.30
	kW	10.16	11.15	11.25	10.21	10.31	11.33	11.26	11.35	11.42
70	TC	86.15	87.35	91.50	89.20	94.30	96.10	90.40	94.10	98.95
	SHC	42.10	47.50	59.80	35.50	45.30	49.50	29.50	33.90	38.70
	kW	9.84	10.83	10.94	10.02	10.13	11.03	10.95	11.05	11.12
60	TC	88.90	90.10	94.25	92.00	97.10	98.20	93.20	96.90	101.75
	SHC	46.80	52.30	64.60	40.20	50.10	54.10	34.10	38.60	43.40
	kW	9.37	10.36	10.44	9.42	9.52	10.55	10.45	10.57	10.64
50	TC	91.70	92.80	97.00	94.80	99.90	101.00	96.10	99.70	104.20
	SHC	51.50	57.10	69.40	44.80	54.80	58.90	38.70	43.20	49.00
	kW	9.12	10.09	10.16	9.17	9.28	10.26	10.17	10.26	10.32
40	TC	94.45	95.60	99.80	97.45	102.55	103.70	98.65	102.35	107.00
	SHC	56.30	61.40	73.70	49.70	59.20	63.30	43.60	48.10	52.90
	kW	9.05	10.02	10.10	9.10	9.21	10.18	10.11	10.20	10.26

LEGEND

- Edb** – Entering Dry–Bulb
- Ewb** – Entering Wet–Bulb
- kW** – Compressor Motor Power Input
- ldb** – Leaving Dry–Bulb
- lwb** – Leaving Wet–Bulb
- SHC** – Sensible Heat Capacity (1000 Btuh) Gross
- TC** – Total Capacity (1000 Btuh) Gross

Table 7 – STATIC PRESSURE ADDERS (IN. WG) (FACTORY OPTIONS AND/OR ACCESSORIES)

Electric Heaters

3–6 TONS											
CFM	600	900	1200	1400	1600	1800	2000	2200	2400	2600	
1 Electric Heater Module	0.03	0.05	0.07	0.09	0.09	0.10	0.11	0.11	0.12	0.13	
2 Electric Heater Modules	0.13	0.15	0.16	0.16	0.16	0.17	0.17	0.17	0.18	0.18	

7.5 – 12.5 TONS																
CFM	2250	2500	2750	3000	3250	3500	3750	4000	4250	4500	4750	5000	5250	5500	5750	6000
1 Electric Heater Module	0.03	0.04	0.04	0.05	0.06	0.07	0.08	0.09	0.10	0.11	0.12	0.13	0.14	0.15	0.16	0.18
2 Electric Heater Modules	0.04	0.05	0.05	0.06	0.07	0.08	0.09	0.10	0.11	0.12	0.13	0.15	0.16	0.17	0.19	0.20

15 TON													
CFM	2813	3125	3438	3750	4063	4375	4688	5000	5313	5625	5938	6250	
Vertical - 1 Electric Heater Module	0.01	0.01	0.02	0.02	0.02	0.02	0.02	0.03	0.03	0.03	0.03	0.04	0.04
Vertical - 2 Electric Heater Modules	0.02	0.03	0.03	0.03	0.04	0.04	0.05	0.05	0.06	0.06	0.07	0.08	0.08
Horizontal - 1 Electric Heater Module	0.03	0.03	0.04	0.04	0.05	0.05	0.06	0.06	0.07	0.07	0.08	0.09	0.09
Horizontal - 2 Electric Heater Modules	0.02	0.03	0.03	0.04	0.04	0.04	0.05	0.05	0.06	0.06	0.07	0.08	0.08

Humidi-MiZer

3–6 TONS										
CFM	1000	1250	1500	1750	2000	2250	2500	2750	3000	
3 Tons	0.04	0.052	0.07	–	–	–	–	–	–	–
4 Tons	–	0.106	0.138	0.172	0.21	–	–	–	–	–
5 Tons	–	–	0.138	0.172	0.21	0.252	0.30	–	–	–
6 Tons	–	–	–	0.112	0.125	0.161	0.19	0.22	0.25	–

7.5–12.5 TONS																
CFM	2250	2500	2750	3000	3250	3500	3750	4000	4250	4500	4750	5000	5250	5500	5750	6000
7.5 Tons	0.12	0.14	0.16	0.19	0.21	0.23	0.26	–	–	–	–	–	–	–	–	–
8.5 Tons	–	0.11	0.12	0.13	0.15	0.17	0.18	0.20	0.22	–	–	–	–	–	–	–
10 Tons	–	–	–	0.13	0.15	0.17	0.18	0.20	0.22	0.24	0.26	0.28	–	–	–	–
12.5 Tons	–	–	–	–	–	0.17	0.18	0.20	0.22	0.24	0.26	0.28	0.31	0.33	0.36	0.39

15 TONS														
CFM	4000	4250	4500	4750	5000	5250	5500	5750	6000	6250	6500	6750	7000	7250
15 Tons	0.06	0.07	0.07	0.08	0.08	0.09	0.10	0.10	0.11	0.12	0.12	0.13	0.14	0.15

ECONOMIZER, BAROMETRIC RELIEF AND PE PERFORMANCE

Vertical Application

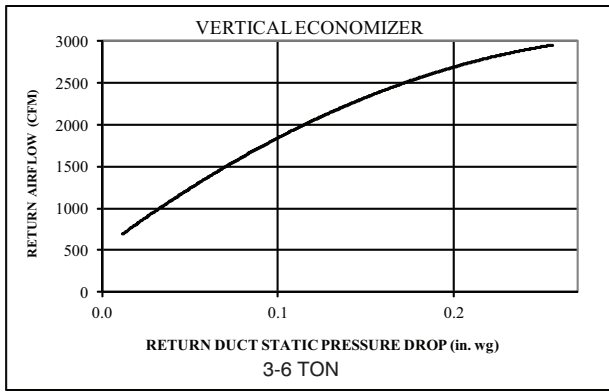

Fig. 16 - Return Air Pressure Drop

C11238

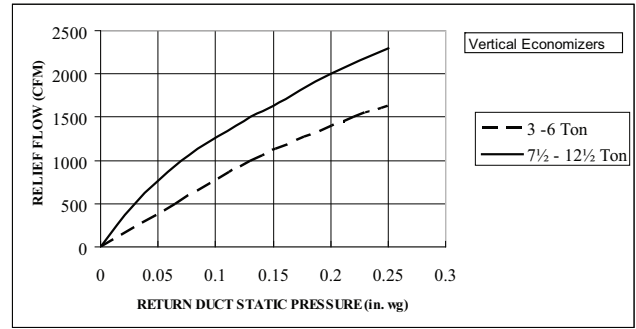

Fig. 19 - Barometric Relief Flow Capacity

C08073

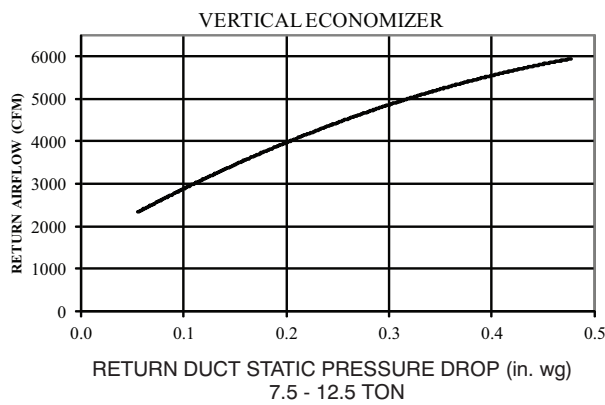

Fig. 17 - Return Air Pressure Drop

C11240

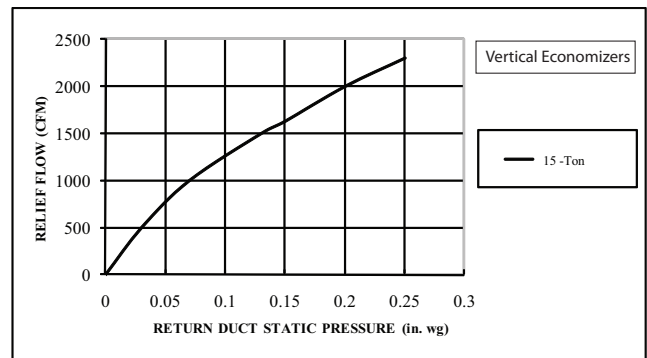

Fig. 20 - Barometric Relief Flow-Vertical 15 Ton

C101122

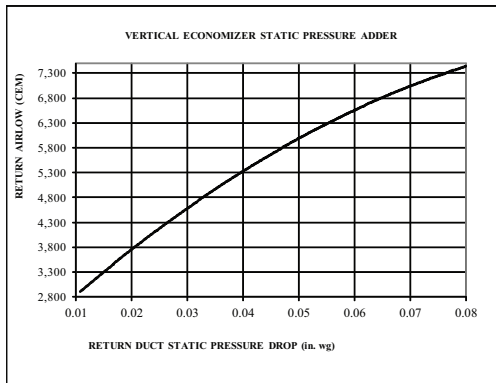

Fig. 18 - Return Air Pressure Drop-Vertical 15 Tons

C11257

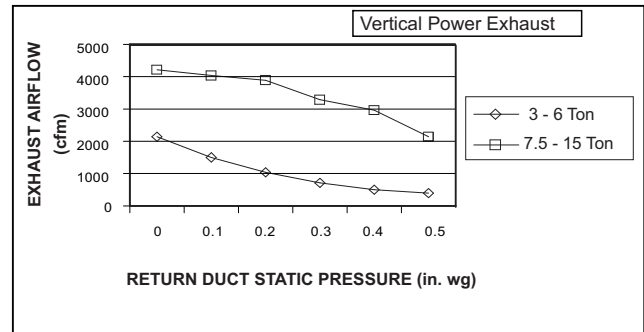

Fig. 21 - Vertical Power Exhaust Performance

C11248

ECONOMIZER, BAROMETRIC RELIEF AND PE PERFORMANCE (cont.)

Horizontal Application

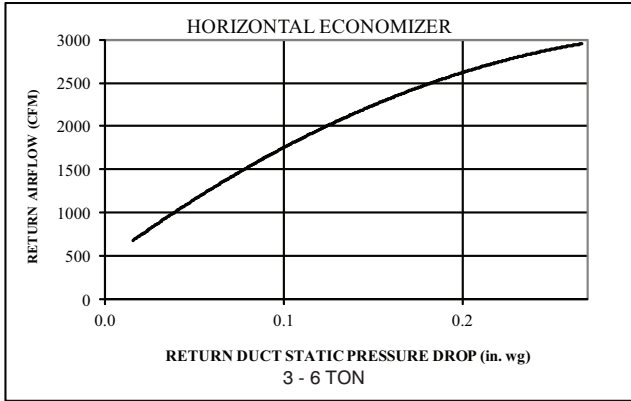

Fig. 22 - Return Air Pressure Drop

C11239

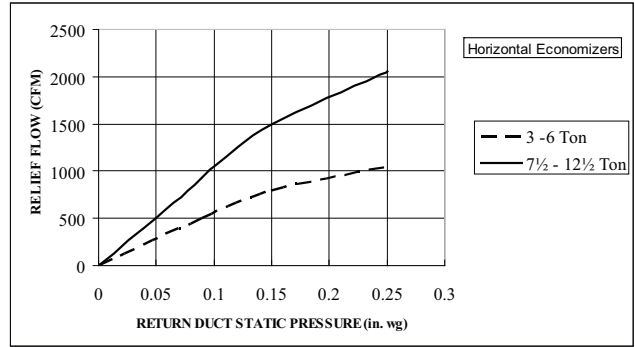

Fig. 25 - Barometric Relief Flow Capacity

C08070

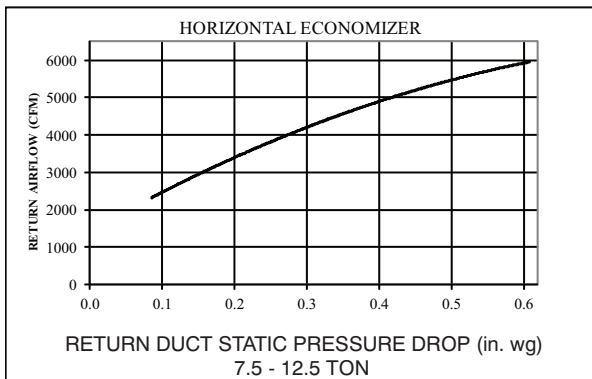

Fig. 23 - Return Air Pressure Drop

C11241

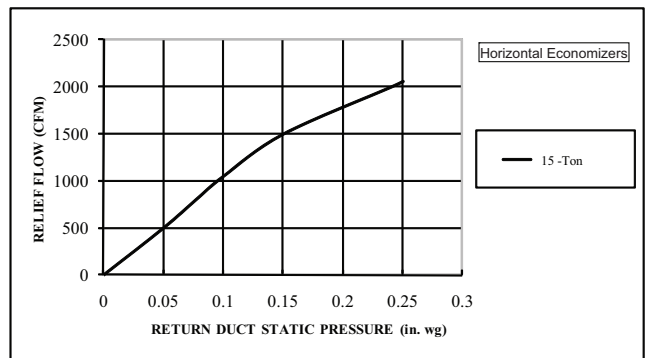

Fig. 26 - Barometric Relief Flow-Horizontal 15 Ton

C101120

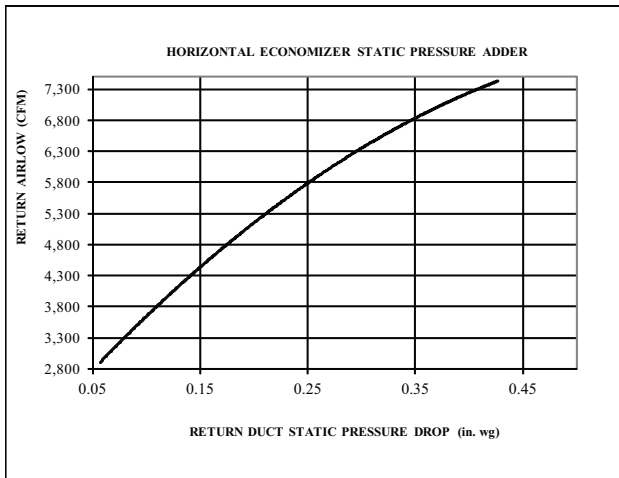

Fig. 24 - Return Air Pressure Drop-Horizontal 15 Ton

C11258

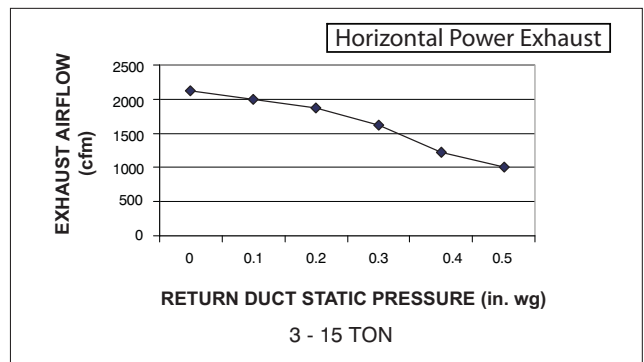

Fig. 27 - Horizontal Power Exhaust Performance

C08012

GENERAL FAN PERFORMANCE NOTES

1. Interpolation is permissible. Do not extrapolate.
2. External static pressure is the static pressure difference between the return duct and the supply duct plus the static pressure caused by any FIOPs or accessories.
3. Tabular data accounts for pressure loss due to clean filters, unit casing, and wet coils. Factory options and accessories may add static pressure losses. Selection software is available, through your salesperson, to help you select the best motor/drive combination for your application.
4. The Fan Performance tables offer motor/drive recommendations. In cases when two motor/drive combinations would work, Carrier recommended the lower horsepower option.
5. For information on the electrical properties of Carrier motors, please see the Electrical information section of this book.
6. For more information on the performance limits of Carrier motors, see the application data section of this book.
7. The EPACT (Energy Policy Act of 1992) regulates energy requirements for specific types of indoor fan motors. Motors regulated by EPACT include any general purpose, T-frame (three-digit, 143 and larger), single-speed, foot mounted, polyphase, squirrel cage induction motors of NEMA (National Electrical Manufacturers Association) design A and B, manufactured for use in the United States. Ranging from 1 to 200 Hp, these continuous-duty motors operate on 230 and 460 volt, 60 Hz power. If a motor does not fit into these specifications, the motor does not have to be replaced by an EPACT compliant energy-efficient motor. Variable-speed motors are exempt from EPACT compliance requirements. Therefore, the indoor fan motors for Carrier 50TC04-16 units are exempt from these requirements.

FAN PERFORMANCE

Table 8 – 50TC04**

1 PHASE

3 TON HORIZONTAL SUPPLY

CFM	AVAILABLE EXTERNAL STATIC PRESSURE (IN. WG)									
	0.2		0.4		0.6		0.8		1.0	
	RPM	BHP	RPM	BHP	RPM	BHP	RPM	BHP	RPM	BHP
	Field Supplied Drive ¹		Standard Static Option				Medium Static Option			
900	554	0.14	681	0.22	783	0.32	870	0.42	947	0.53
975	575	0.16	701	0.25	801	0.35	888	0.45	965	0.57
1050	597	0.18	721	0.28	821	0.38	906	0.49	983	0.61
1125	620	0.21	741	0.31	840	0.42	925	0.54	1001	0.66
1200	643	0.23	762	0.35	860	0.46	944	0.58	1020	0.71
1275	666	0.27	784	0.38	880	0.50	964	0.63	1039	0.76
1350	690	0.30	805	0.42	900	0.55	983	0.68	1058	0.82
1425	714	0.34	827	0.47	921	0.60	1003	0.74	1077	0.88
1500	738	0.38	849	0.52	942	0.66	1024	0.80	1097	0.95

CFM	AVAILABLE EXTERNAL STATIC PRESSURE (IN. WG)									
	1.2		1.4		1.6		1.8		2.0	
	RPM	BHP	RPM	BHP	RPM	BHP	RPM	BHP	RPM	BHP
	Medium Static Option					Field Supplied Drive ²				
900	1017	0.64	1082	0.76	1143	0.88	1200	1.01	1254	1.14
975	1035	0.68	1100	0.81	1160	0.93	1217	1.07	1271	1.20
1050	1053	0.73	1117	0.86	1177	0.99	1234	1.13	-	-
1125	1071	0.78	1135	0.92	1195	1.05	1251	1.19	-	-
1200	1089	0.84	1153	0.98	1212	1.12	-	-	-	-
1275	1107	0.90	1171	1.04	1230	1.19	-	-	-	-
1350	1126	0.96	1189	1.11	-	-	-	-	-	-
1425	1145	1.03	1208	1.18	-	-	-	-	-	-
1500	1164	1.10	-	-	-	-	-	-	-	-

NOTE: For more information, see General Fan Performance Notes.

Boldface indicates field-supplied drive is required.

1. Recommend using field-supplied fan pulley (part no. KR11AG006) and belt (part no. KR30AE039).
2. Recommend using field-supplied motor pulley (part no. KR11HY161) and belt (part no. KR30AE035).

Table 8 (cont.) 50TC04**

1 PHASE

3 TON VERTICAL SUPPLY

CFM	AVAILABLE EXTERNAL STATIC PRESSURE (IN. WG)									
	0.2		0.4		0.6		0.8		1.0	
	RPM	BHP	RPM	BHP	RPM	BHP	RPM	BHP	RPM	BHP
	Field Supplied Drive ¹		Standard Static Option				Medium Static Option			
900	566	0.14	690	0.23	791	0.32	879	0.42	957	0.52
975	590	0.17	711	0.26	811	0.36	897	0.46	975	0.57
1050	615	0.19	733	0.29	831	0.39	916	0.50	993	0.62
1125	640	0.22	755	0.33	851	0.43	936	0.55	1012	0.67
1200	666	0.25	778	0.36	873	0.48	956	0.60	1031	0.72
1275	692	0.29	802	0.41	894	0.53	976	0.65	1051	0.78
1350	719	0.33	825	0.45	916	0.58	997	0.71	1071	0.84
1425	746	0.37	850	0.50	939	0.63	1019	0.77	1091	0.91
1500	774	0.42	875	0.55	962	0.69	1041	0.83	1112	0.98

CFM	AVAILABLE EXTERNAL STATIC PRESSURE (IN. WG)									
	1.2		1.4		1.6		1.8		2.0	
	RPM	BHP	RPM	BHP	RPM	BHP	RPM	BHP	RPM	BHP
	Medium Static Option					Field Supplied Drive ²				
900	1029	0.63	1095	0.75	1157	0.86	1216	0.99	1272	1.11
975	1046	0.68	1112	0.80	1174	0.92	1232	1.05	1287	1.18
1050	1064	0.73	1129	0.86	1190	0.98	1248	1.11	-	-
1125	1082	0.79	1147	0.92	1208	1.05	1265	1.18	-	-
1200	1100	0.85	1165	0.98	1225	1.12	-	-	-	-
1275	1119	0.91	1183	1.05	1243	1.19	-	-	-	-
1350	1139	0.98	1202	1.12	-	-	-	-	-	-
1425	1159	1.05	1221	1.20	-	-	-	-	-	-
1500	1179	1.13	-	-	-	-	-	-	-	-

NOTE: For more information, see General Fan Performance Notes.

Boldface indicates field-supplied drive is required.

1. Recommend using field-supplied fan pulley (part no. KR11AG006) and belt (part no. KR30AE039).
2. Recommend using field-supplied motor pulley (part no. KR11HY161) and belt (part no. KR30AE035).

FAN PERFORMANCE (cont.)

Table 8 (cont.) 50TC04**

3 PHASE

3 TON HORIZONTAL SUPPLY

CFM	AVAILABLE EXTERNAL STATIC PRESSURE (IN. WG)									
	0.2		0.4		0.6		0.8		1.0	
	RPM	BHP	RPM	BHP	RPM	BHP	RPM	BHP	RPM	BHP
	Field Supplied Drive ¹		Standard Static Option				Medium Static Option			
900	554	0.14	681	0.22	783	0.32	870	0.42	947	0.53
975	575	0.16	701	0.25	801	0.35	888	0.45	965	0.57
1050	597	0.18	721	0.28	821	0.38	906	0.49	983	0.61
1125	620	0.21	741	0.31	840	0.42	925	0.54	1001	0.66
1200	643	0.23	762	0.35	860	0.46	944	0.58	1020	0.71
1275	666	0.27	784	0.38	880	0.50	964	0.63	1039	0.76
1350	690	0.30	805	0.42	900	0.55	983	0.68	1058	0.82
1425	714	0.34	827	0.47	921	0.60	1003	0.74	1077	0.88
1500	738	0.38	849	0.52	942	0.66	1024	0.80	1097	0.95

CFM	AVAILABLE EXTERNAL STATIC PRESSURE (IN. WG)									
	1.2		1.4		1.6		1.8		2.0	
	RPM	BHP	RPM	BHP	RPM	BHP	RPM	BHP	RPM	BHP
	Medium Static Option					High Static Option				
900	1017	0.64	1082	0.76	1143	0.88	1200	1.01	1254	1.14
975	1035	0.68	1100	0.81	1160	0.93	1217	1.07	1271	1.20
1050	1053	0.73	1117	0.86	1177	0.99	1234	1.13	1288	1.27
1125	1071	0.78	1135	0.92	1195	1.05	1251	1.19	1305	1.34
1200	1089	0.84	1153	0.98	1212	1.12	1269	1.26	1322	1.41
1275	1107	0.90	1171	1.04	1230	1.19	1286	1.33	1340	1.49
1350	1126	0.96	1189	1.11	1249	1.26	1304	1.41	1357	1.57
1425	1145	1.03	1208	1.18	1267	1.33	1323	1.49	1375	1.66
1500	1164	1.10	1227	1.25	1285	1.41	1341	1.58	1394	1.75

NOTE: For more information, see General Fan Performance Notes.

Boldface indicates field-supplied drive is required.

1. Recommend using field-supplied fan pulley (part no. KR11AG006) and belt (part no. KR30AE039).

Table 8 (cont.) 50TC04**

3 PHASE

3 TON VERTICAL SUPPLY

CFM	AVAILABLE EXTERNAL STATIC PRESSURE (IN. WG)									
	0.2		0.4		0.6		0.8		1.0	
	RPM	BHP	RPM	BHP	RPM	BHP	RPM	BHP	RPM	BHP
	Field Supplied Drive ¹		Standard Static Option				Medium Static Option			
900	566	0.14	690	0.23	791	0.32	879	0.42	957	0.52
975	590	0.17	711	0.26	811	0.36	897	0.46	975	0.57
1050	615	0.19	733	0.29	831	0.39	916	0.50	993	0.62
1125	640	0.22	755	0.33	851	0.43	936	0.55	1012	0.67
1200	666	0.25	778	0.36	873	0.48	956	0.60	1031	0.72
1275	692	0.29	802	0.41	894	0.53	976	0.65	1051	0.78
1350	719	0.33	825	0.45	916	0.58	997	0.71	1071	0.84
1425	746	0.37	850	0.50	939	0.63	1019	0.77	1091	0.91
1500	774	0.42	875	0.55	962	0.69	1041	0.83	1112	0.98

CFM	AVAILABLE EXTERNAL STATIC PRESSURE (IN. WG)									
	1.2		1.4		1.6		1.8		2.0	
	RPM	BHP	RPM	BHP	RPM	BHP	RPM	BHP	RPM	BHP
	Medium Static Option					High Static Option				
900	1029	0.63	1095	0.75	1157	0.86	1216	0.99	1272	1.11
975	1046	0.68	1112	0.80	1174	0.92	1232	1.05	1287	1.18
1050	1064	0.73	1129	0.86	1190	0.98	1248	1.11	1304	1.25
1125	1082	0.79	1147	0.92	1208	1.05	1265	1.18	1320	1.32
1200	1100	0.85	1165	0.98	1225	1.12	1282	1.26	1337	1.40
1275	1119	0.91	1183	1.05	1243	1.19	1300	1.34	1354	1.49
1350	1139	0.98	1202	1.12	1262	1.27	1318	1.42	1372	1.57
1425	1159	1.05	1221	1.20	1280	1.35	1336	1.51	1390	1.66
1500	1179	1.13	1241	1.28	1300	1.44	1355	1.60	1408	1.76

NOTE: For more information, see General Fan Performance Notes.

Boldface indicates field-supplied drive is required.

1. Recommend using field-supplied fan pulley (part no. KR11AG006) and belt (part no. KR30AE039).

FAN PERFORMANCE (cont.)

Table 8 (cont.) 50TC**05

1 PHASE

4 TON HORIZONTAL SUPPLY

CFM	AVAILABLE EXTERNAL STATIC PRESSURE (IN. WG)									
	0.2		0.4		0.6		0.8		1.0	
	RPM	BHP	RPM	BHP	RPM	BHP	RPM	BHP	RPM	BHP
	Standard Static Option					Medium Static Option				
1200	643	0.23	762	0.35	860	0.46	944	0.58	1020	0.71
1300	674	0.28	791	0.40	887	0.52	970	0.65	1045	0.78
1400	706	0.33	820	0.45	914	0.59	997	0.72	1071	0.86
1500	738	0.38	849	0.52	942	0.66	1024	0.80	1097	0.95
1600	771	0.44	879	0.59	971	0.74	1051	0.89	1124	1.04
1700	804	0.51	910	0.66	1000	0.82	1079	0.98	1151	1.14
1800	837	0.59	941	0.75	1029	0.91	1107	1.08	-	-
1900	871	0.67	972	0.84	1059	1.02	1136	1.19	-	-
2000	906	0.76	1004	0.94	1089	1.12	-	-	-	-

CFM	AVAILABLE EXTERNAL STATIC PRESSURE (IN. WG)									
	1.2		1.4		1.6		1.8		2.0	
	RPM	BHP	RPM	BHP	RPM	BHP	RPM	BHP	RPM	BHP
	Medium Static Option					Field Supplied Drive ¹				
1200	1089	0.84	1153	0.98	1212	1.12	-	-	-	-
1300	1114	0.92	1177	1.06	-	-	-	-	-	-
1400	1139	1.01	1202	1.15	-	-	-	-	-	-
1500	1164	1.10	-	-	-	-	-	-	-	-
1600	1190	1.20	-	-	-	-	-	-	-	-
1700	-	-	-	-	-	-	-	-	-	-
1800	-	-	-	-	-	-	-	-	-	-
1900	-	-	-	-	-	-	-	-	-	-
2000	-	-	-	-	-	-	-	-	-	-

NOTE: For more information, see General Fan Performance Notes.

Boldface indicates field-supplied drive is required.

1. Recommend using field-supplied motor pulley (part no. KR11HY161) and belt (part no. KR30AE035).

Table 8 (cont.) 50TC**05

1 PHASE

4 TON VERTICAL SUPPLY

CFM	AVAILABLE EXTERNAL STATIC PRESSURE (IN. WG)									
	0.2		0.4		0.6		0.8		1.0	
	RPM	BHP	RPM	BHP	RPM	BHP	RPM	BHP	RPM	BHP
	Standard Static Option					Medium Static Option				
1200	666	0.25	778	0.36	873	0.48	956	0.60	1031	0.72
1300	701	0.30	809	0.42	902	0.54	983	0.67	1057	0.80
1400	737	0.36	842	0.48	932	0.61	1012	0.75	1085	0.89
1500	774	0.42	875	0.55	962	0.69	1041	0.83	1112	0.98
1600	811	0.49	909	0.63	994	0.78	1071	0.93	1141	1.08
1700	849	0.57	943	0.72	1026	0.87	1101	1.03	1170	1.19
1800	887	0.65	978	0.81	1059	0.98	1133	1.14	-	-
1900	926	0.75	1014	0.92	1092	1.09	-	-	-	-
2000	965	0.86	1050	1.03	-	-	-	-	-	-

CFM	AVAILABLE EXTERNAL STATIC PRESSURE (IN. WG)									
	1.2		1.4		1.6		1.8		2.0	
	RPM	BHP	RPM	BHP	RPM	BHP	RPM	BHP	RPM	BHP
	Medium Static Option					Field Supplied Drive ¹				
1200	1100	0.85	1165	0.98	1225	1.12	-	-	-	-
1300	1126	0.94	1189	1.07	-	-	-	-	-	-
1400	1152	1.03	1215	1.17	-	-	-	-	-	-
1500	1179	1.13	-	-	-	-	-	-	-	-
1600	1206	1.24	-	-	-	-	-	-	-	-
1700	1235	1.36	-	-	-	-	-	-	-	-
1800	1264	1.48	-	-	-	-	-	-	-	-
1900	1293	1.62	-	-	-	-	-	-	-	-
2000	1324	1.77	-	-	-	-	-	-	-	-

NOTE: For more information, see General Fan Performance Notes.

Boldface indicates field-supplied drive is required.

1. Recommend using field-supplied motor pulley (part no. KR11HY161) and belt (part no. KR30AE035).

FAN PERFORMANCE (cont.)

Table 8 (cont.) 50TC**05

3 PHASE

4 TON HORIZONTAL SUPPLY

CFM	AVAILABLE EXTERNAL STATIC PRESSURE (IN. WG)									
	0.2		0.4		0.6		0.8		1.0	
	RPM	BHP	RPM	BHP	RPM	BHP	RPM	BHP	RPM	BHP
	Standard Static Option					Medium Static Option				
1200	643	0.23	762	0.35	860	0.46	944	0.58	1020	0.71
1300	674	0.28	791	0.40	887	0.52	970	0.65	1045	0.78
1400	706	0.33	820	0.45	914	0.59	997	0.72	1071	0.86
1500	738	0.38	849	0.52	942	0.66	1024	0.80	1097	0.95
1600	771	0.44	879	0.59	971	0.74	1051	0.89	1124	1.04
1700	804	0.51	910	0.66	1000	0.82	1079	0.98	1151	1.14
1800	837	0.59	941	0.75	1029	0.91	1107	1.08	1178	1.25
1900	871	0.67	972	0.84	1059	1.02	1136	1.19	1206	1.37
2000	906	0.76	1004	0.94	1089	1.12	1165	1.31	1234	1.49

CFM	AVAILABLE EXTERNAL STATIC PRESSURE (IN. WG)									
	1.2		1.4		1.6		1.8		2.0	
	RPM	BHP	RPM	BHP	RPM	BHP	RPM	BHP	RPM	BHP
	Medium Static Option					High Static Option				
1200	1089	0.84	1153	0.98	1212	1.12	1269	1.26	1322	1.41
1300	1114	0.92	1177	1.06	1236	1.21	1292	1.36	1346	1.52
1400	1139	1.01	1202	1.15	1261	1.31	1316	1.47	1369	1.63
1500	1164	1.10	1227	1.25	1285	1.41	1341	1.58	1394	1.75
1600	1190	1.20	1252	1.36	1311	1.53	1366	1.70	1418	1.87
1700	1217	1.31	1278	1.48	1336	1.65	1391	1.83	1443	2.01
1800	1244	1.42	1305	1.60	1362	1.78	1416	1.97	1468	2.15
1900	1271	1.55	1331	1.73	1388	1.92	1442	2.11	1494	2.31
2000	1298	1.68	1358	1.87	1415	2.07	1468	2.27	-	-

NOTE: For more information, see General Fan Performance Notes.

Boldface indicates field-supplied drive is required.

1. Recommend using field-supplied fan pulley (part no. KR11AZ506), motor pulley (part no. KR11HY181) and belt (part no. KR30AE041).

Table 8 (cont.) 50TC**05

3 PHASE

4 TON VERTICAL SUPPLY

CFM	AVAILABLE EXTERNAL STATIC PRESSURE (IN. WG)									
	0.2		0.4		0.6		0.8		1.0	
	RPM	BHP	RPM	BHP	RPM	BHP	RPM	BHP	RPM	BHP
	Standard Static Option					Medium Static Option				
1200	666	0.25	778	0.36	873	0.48	956	0.60	1031	0.72
1300	701	0.30	809	0.42	902	0.54	983	0.67	1057	0.80
1400	737	0.36	842	0.48	932	0.61	1012	0.75	1085	0.89
1500	774	0.42	875	0.55	962	0.69	1041	0.83	1112	0.98
1600	811	0.49	909	0.63	994	0.78	1071	0.93	1141	1.08
1700	849	0.57	943	0.72	1026	0.87	1101	1.03	1170	1.19
1800	887	0.65	978	0.81	1059	0.98	1133	1.14	1200	1.31
1900	926	0.75	1014	0.92	1092	1.09	1164	1.26	1231	1.44
2000	965	0.86	1050	1.03	1127	1.21	1197	1.39	1262	1.58

CFM	AVAILABLE EXTERNAL STATIC PRESSURE (IN. WG)									
	1.2		1.4		1.6		1.8		2.0	
	RPM	BHP	RPM	BHP	RPM	BHP	RPM	BHP	RPM	BHP
	Medium Static Option					High Static Option				
1200	1100	0.85	1165	0.98	1225	1.12	1282	1.26	1337	1.40
1300	1126	0.94	1189	1.07	1249	1.22	1306	1.36	1360	1.51
1400	1152	1.03	1215	1.17	1274	1.32	1330	1.48	1384	1.63
1500	1179	1.13	1241	1.28	1300	1.44	1355	1.60	1408	1.76
1600	1206	1.24	1268	1.40	1326	1.56	1381	1.73	1433	1.90
1700	1235	1.36	1295	1.52	1352	1.69	1407	1.87	1459	2.04
1800	1264	1.48	1323	1.66	1380	1.84	1434	2.02	1485	2.20
1900	1293	1.62	1352	1.80	1408	1.99	1461	2.17	1512	2.37
2000	1324	1.77	1381	1.96	1436	2.15	1489	2.34	-	-

NOTE: For more information, see General Fan Performance Notes.

Boldface indicates field-supplied drive is required.

1. Recommend using field-supplied fan pulley (part no. KR11AZ506), motor pulley (part no. KR11HY181) and belt (part no. KR30AE041).

FAN PERFORMANCE (cont.)

Table 8 (cont.) 50TC**06

1 PHASE

5 TON HORIZONTAL SUPPLY

CFM	AVAILABLE EXTERNAL STATIC PRESSURE (IN. WG)									
	0.2		0.4		0.6		0.8		1.0	
	RPM	BHP	RPM	BHP	RPM	BHP	RPM	BHP	RPM	BHP
	Field Supplied Drive¹		Standard Static Option							
1500	724	0.33	837	0.45	937	0.59	1028	0.74	1111	0.91
1625	765	0.40	873	0.53	969	0.67	1056	0.83	1137	1.00
1750	806	0.48	909	0.61	1002	0.76	1087	0.92	1165	1.10
1875	849	0.57	947	0.71	1036	0.86	1118	1.03	1195	1.21
2000	892	0.67	986	0.82	1072	0.98	1151	1.15	1226	1.33
2125	935	0.79	1025	0.94	1108	1.11	1185	1.29	1258	1.47
2250	980	0.92	1066	1.08	1146	1.25	1220	1.43	-	-
2375	1024	1.06	1107	1.23	1184	1.41	-	-	-	-
2500	1069	1.22	1149	1.39	-	-	-	-	-	-

CFM	AVAILABLE EXTERNAL STATIC PRESSURE (IN. WG)									
	1.2		1.4		1.6		1.8		2.0	
	RPM	BHP	RPM	BHP	RPM	BHP	RPM	BHP	RPM	BHP
	Medium Static Option									
1500	1188	1.09	1261	1.29	1330	1.49	-	-	-	-
1625	1213	1.18	1284	1.38	-	-	-	-	-	-
1750	1239	1.28	1309	1.49	-	-	-	-	-	-
1875	1267	1.40	-	-	-	-	-	-	-	-
2000	-	-	-	-	-	-	-	-	-	-
2125	-	-	-	-	-	-	-	-	-	-
2250	-	-	-	-	-	-	-	-	-	-
2375	-	-	-	-	-	-	-	-	-	-
2500	-	-	-	-	-	-	-	-	-	-

NOTE: For more information, see General Fan Performance Notes.

Boldface indicates field-supplied drive is required.

1. Recommend using field-supplied fan pulley (part no. KR11AZ606) and belt (part no. KR30AE037).

Table 8 (cont.) 50TC**06

1 PHASE

5 TON VERTICAL SUPPLY

CFM	AVAILABLE EXTERNAL STATIC PRESSURE (IN. WG)									
	0.2		0.4		0.6		0.8		1.0	
	RPM	BHP	RPM	BHP	RPM	BHP	RPM	BHP	RPM	BHP
	Standard Static Option									
1500	790	0.40	897	0.53	991	0.68	1075	0.83	1152	1.00
1625	837	0.48	940	0.62	1030	0.77	1112	0.94	1187	1.11
1750	885	0.58	983	0.73	1070	0.89	1150	1.06	1223	1.24
1875	934	0.69	1027	0.85	1112	1.01	1189	1.19	1260	1.38
2000	983	0.81	1073	0.98	1154	1.16	1229	1.34	-	-
2125	1033	0.95	1119	1.13	1198	1.31	1270	1.50	-	-
2250	1084	1.11	1166	1.29	1242	1.49	-	-	-	-
2375	1134	1.28	1214	1.48	-	-	-	-	-	-
2500	1185	1.48	-	-	-	-	-	-	-	-

CFM	AVAILABLE EXTERNAL STATIC PRESSURE (IN. WG)									
	1.2		1.4		1.6		1.8		2.0	
	RPM	BHP	RPM	BHP	RPM	BHP	RPM	BHP	RPM	BHP
	Medium Static Option									
1500	1224	1.18	1291	1.36	-	-	-	-	-	-
1625	1257	1.30	1323	1.49	-	-	-	-	-	-
1750	1292	1.43	-	-	-	-	-	-	-	-
1875	-	-	-	-	-	-	-	-	-	-
2000	-	-	-	-	-	-	-	-	-	-
2125	-	-	-	-	-	-	-	-	-	-
2250	-	-	-	-	-	-	-	-	-	-
2375	-	-	-	-	-	-	-	-	-	-
2500	-	-	-	-	-	-	-	-	-	-

NOTE: For more information, see General Fan Performance Notes.

Boldface indicates field-supplied drive is required.

FAN PERFORMANCE (cont.)

Table 8 (cont.) 50TC**06

3 PHASE

5 TON HORIZONTAL SUPPLY

CFM	AVAILABLE EXTERNAL STATIC PRESSURE (IN. WG)									
	0.2		0.4		0.6		0.8		1.0	
	RPM	BHP	RPM	BHP	RPM	BHP	RPM	BHP	RPM	BHP
	Field Supplied Drive¹		Standard Static Option							
1500	724	0.33	837	0.45	937	0.59	1028	0.74	1111	0.91
1625	765	0.40	873	0.53	969	0.67	1056	0.83	1137	1.00
1750	806	0.48	909	0.61	1002	0.76	1087	0.92	1165	1.10
1875	849	0.57	947	0.71	1036	0.86	1118	1.03	1195	1.21
2000	892	0.67	986	0.82	1072	0.98	1151	1.15	1226	1.33
2125	935	0.79	1025	0.94	1108	1.11	1185	1.29	1258	1.47
2250	980	0.92	1066	1.08	1146	1.25	1220	1.43	1291	1.63
2375	1024	1.06	1107	1.23	1184	1.41	1256	1.60	1325	1.79
2500	1069	1.22	1149	1.39	1223	1.58	1293	1.77	1360	1.98

CFM	AVAILABLE EXTERNAL STATIC PRESSURE (IN. WG)									
	1.2		1.4		1.6		1.8		2.0	
	RPM	BHP	RPM	BHP	RPM	BHP	RPM	BHP	RPM	BHP
	Medium Static Option									
1500	1188	1.09	1261	1.29	1330	1.49	1395	1.71	1457	1.95
1625	1213	1.18	1284	1.38	1352	1.59	1416	1.81	1478	2.04
1750	1239	1.28	1309	1.49	1375	1.70	1439	1.92	1499	2.16
1875	1267	1.40	1335	1.60	1400	1.82	1462	2.04	1522	2.28
2000	1296	1.53	1363	1.74	1427	1.95	1488	2.18	1546	2.42
2125	1326	1.67	1392	1.88	1454	2.11	1514	2.34	1571	2.58
2250	1358	1.83	1421	2.05	1483	2.27	1541	2.51	1598	2.75
2375	1390	2.00	1452	2.22	1512	2.45	1570	2.69	1625	2.94
2500	1424	2.19	1484	2.42	1543	2.65	1599	2.89	1654	3.15

NOTE: For more information, see General Fan Performance Notes.

Boldface indicates field-supplied drive is required.

1. Recommend using field-supplied fan pulley (part no. KR11AZ606) and belt (part no. KR30AE037).

Table 8 (cont.) 50TC**06

3 PHASE

5 TON VERTICAL SUPPLY

CFM	AVAILABLE EXTERNAL STATIC PRESSURE (IN. WG)									
	0.2		0.4		0.6		0.8		1.0	
	RPM	BHP	RPM	BHP	RPM	BHP	RPM	BHP	RPM	BHP
	Standard Static Option									
1500	790	0.40	897	0.53	991	0.68	1075	0.83	1152	1.00
1625	837	0.48	940	0.62	1030	0.77	1112	0.94	1187	1.11
1750	885	0.58	983	0.73	1070	0.89	1150	1.06	1223	1.24
1875	934	0.69	1027	0.85	1112	1.01	1189	1.19	1260	1.38
2000	983	0.81	1073	0.98	1154	1.16	1229	1.34	1299	1.53
2125	1033	0.95	1119	1.13	1198	1.31	1270	1.50	1338	1.71
2250	1084	1.11	1166	1.29	1242	1.49	1312	1.69	1386	1.89
2375	1134	1.28	1214	1.48	1287	1.68	1355	1.89	1420	2.10
2500	1185	1.48	1262	1.68	1333	1.89	1399	2.10	1462	2.33

CFM	AVAILABLE EXTERNAL STATIC PRESSURE (IN. WG)									
	1.2		1.4		1.6		1.8		2.0	
	RPM	BHP	RPM	BHP	RPM	BHP	RPM	BHP	RPM	BHP
	Medium Static Option								High Static Option	
1500	1224	1.18	1291	1.36	1354	1.56	1414	1.77	1472	1.98
1625	1257	1.30	1323	1.49	1385	1.69	1445	1.90	1501	2.12
1750	1292	1.43	1356	1.63	1418	1.83	1476	2.05	1532	2.27
1875	1327	1.57	1391	1.78	1451	1.99	1509	2.21	1564	2.44
2000	1364	1.74	1427	1.95	1486	2.17	1542	2.39	1596	2.63
2125	1402	1.92	1463	2.13	1521	2.36	1577	2.59	1630	2.83
2250	1441	2.11	1501	2.34	1558	2.57	1612	2.81	-	-
2375	1481	2.33	1539	2.56	1595	2.80	-	-	-	-
2500	1522	2.56	1579	2.80	-	-	-	-	-	-

NOTE: For more information, see General Fan Performance Notes.

Boldface indicates field-supplied drive is required.

FAN PERFORMANCE (cont.)

Table 8 (cont.) 50TC**07

3 PHASE

6 TON HORIZONTAL SUPPLY

CFM	AVAILABLE EXTERNAL STATIC PRESSURE (IN. WG)									
	0.2		0.4		0.6		0.8		1.0	
	RPM	BHP	RPM	BHP	RPM	BHP	RPM	BHP	RPM	BHP
Field Supplied Drive ¹					Standard Static Option					
1800	822	0.51	927	0.66	1018	0.82	1100	0.98	1174	1.15
1950	872	0.62	973	0.79	1061	0.95	1140	1.13	1213	1.31
2100	923	0.75	1019	0.92	1104	1.10	1182	1.29	1253	1.48
2250	974	0.90	1067	1.08	1149	1.27	1224	1.46	1294	1.66
2400	1026	1.06	1115	1.26	1195	1.46	1268	1.66	1336	1.87
2550	1079	1.25	1164	1.46	1241	1.67	1312	1.88	1379	2.10
2700	1132	1.46	1214	1.67	1289	1.90	1358	2.12	1422	2.35
2850	1186	1.69	1264	1.92	1336	2.15	1404	2.39	1467	2.63
3000	1240	1.94	1315	2.18	1385	2.43	1451	2.68	1512	2.93

CFM	AVAILABLE EXTERNAL STATIC PRESSURE (IN. WG)									
	1.2		1.4		1.6		1.8		2.0	
	RPM	BHP	RPM	BHP	RPM	BHP	RPM	BHP	RPM	BHP
Standard Static Option								Medium Static Option		
1800	1244	1.33	1308	1.51	1369	1.70	1427	1.90	1483	2.10
1950	1281	1.49	1345	1.68	1405	1.88	1462	2.09	1517	2.30
2100	1320	1.67	1382	1.87	1441	2.08	1498	2.29	1552	2.51
2250	1359	1.87	1420	2.08	1479	2.29	1534	2.51	1587	2.74
2400	1400	2.09	1460	2.31	1517	2.53	1572	2.76	1624	2.99
2550	1441	2.33	1500	2.55	1557	2.79	1610	3.03	1662	3.27
2700	1483	2.59	1541	2.83	1597	3.07	1650	3.32	1701	3.57
2850	1527	2.87	1583	3.12	1638	3.37	1690	3.63	-	-
3000	1571	3.18	1626	3.44	1680	3.70	-	-	-	-

NOTE: For more information, see General Fan Performance Notes.

Boldface indicates field-supplied drive is required.

1. Recommend using field-supplied fan pulley (part no. KR11AZ406), motor pulley (part no. KR11HY151) and belt (part no. KR30AE035).

Table 8 (cont.) 50TC**07

3 PHASE

6 TON VERTICAL SUPPLY

CFM	AVAILABLE EXTERNAL STATIC PRESSURE (IN. WG)									
	0.2		0.4		0.6		0.8		1.0	
	RPM	BHP	RPM	BHP	RPM	BHP	RPM	BHP	RPM	BHP
Field Supplied Drive ¹					Standard Static Option					
1800	907	0.63	1006	0.80	1092	0.97	1169	1.14	1239	1.32
1950	965	0.77	1060	0.95	1143	1.13	1218	1.32	1287	1.51
2100	1024	0.93	1115	1.12	1195	1.32	1268	1.52	1335	1.72
2250	1083	1.11	1170	1.32	1248	1.53	1319	1.74	1385	1.96
2400	1143	1.32	1227	1.54	1302	1.76	1371	1.99	1435	2.22
2550	1203	1.55	1284	1.78	1357	2.02	1424	2.26	1487	2.50
2700	1264	1.81	1342	2.06	1412	2.31	1478	2.56	1539	2.82
2850	1326	2.09	1400	2.36	1469	2.62	1532	2.89	1592	3.16
3000	1387	2.41	1459	2.69	1525	2.97	1587	3.25	1646	3.53

CFM	AVAILABLE EXTERNAL STATIC PRESSURE (IN. WG)									
	1.2		1.4		1.6		1.8		2.0	
	RPM	BHP	RPM	BHP	RPM	BHP	RPM	BHP	RPM	BHP
Standard Static Option						Medium Static Option		High Static Option		
1800	1304	1.51	1365	1.69	1422	1.88	1477	2.08	1528	2.28
1950	1350	1.71	1410	1.91	1467	2.11	1520	2.31	1572	2.52
2100	1398	1.93	1457	2.14	1512	2.35	1565	2.57	1616	2.79
2250	1446	2.18	1504	2.40	1559	2.62	1611	2.85	1661	3.09
2400	1496	2.45	1552	2.68	1606	2.92	1658	3.16	1707	3.40
2550	1546	2.75	1601	2.99	1654	3.24	1705	3.50	-	-
2700	1597	3.07	1651	3.33	1703	3.59	-	-	-	-
2850	1648	3.43	1702	3.70	-	-	-	-	-	-
3000	-	-	-	-	-	-	-	-	-	-

NOTE: For more information, see General Fan Performance Notes.

Boldface indicates field-supplied drive is required.

1. Recommend using field-supplied fan pulley (part no. KR11AZ406), motor pulley (part no. KR11HY151) and belt (part no. KR30AE035).

FAN PERFORMANCE (cont.)

Table 8 (cont.) 50TC**08

3 PHASE

7.5 TON HORIZONTAL SUPPLY

CFM	AVAILABLE EXTERNAL STATIC PRESSURE (IN. WG)									
	0.2		0.4		0.6		0.8		1.0	
	RPM	BHP	RPM	BHP	RPM	BHP	RPM	BHP	RPM	BHP
	Field Supplied Drive¹		Standard Static Option						Medium Static Option	
2250	465	0.43	555	0.64	629	0.86	694	1.10	753	1.34
2438	488	0.51	575	0.73	648	0.97	712	1.21	769	1.47
2625	510	0.60	595	0.84	666	1.09	729	1.34	786	1.62
2813	533	0.70	616	0.95	686	1.22	748	1.49	804	1.77
3000	557	0.82	637	1.08	705	1.36	766	1.64	822	1.94
3188	581	0.94	659	1.23	726	1.51	785	1.81	840	2.12
3375	606	1.08	681	1.38	746	1.68	805	2.00	859	2.32
3563	630	1.24	703	1.55	767	1.87	825	2.20	878	2.53
3750	655	1.41	726	1.74	789	2.07	845	2.41	897	2.76

CFM	AVAILABLE EXTERNAL STATIC PRESSURE (IN. WG)									
	1.2		1.4		1.6		1.8		2.0	
	RPM	BHP	RPM	BHP	RPM	BHP	RPM	BHP	RPM	BHP
	Medium Static Option						High Static Option			
2250	806	1.60	856	1.87	903	2.15	947	2.45	988	2.75
2438	822	1.74	872	2.03	918	2.32	961	2.62	1003	2.93
2625	839	1.90	887	2.19	933	2.49	977	2.81	1018	3.13
2813	856	2.06	904	2.37	949	2.68	992	3.01	1033	3.34
3000	873	2.24	921	2.56	966	2.89	1008	3.22	1049	3.56
3188	891	2.44	938	2.77	982	3.10	1025	3.45	1065	3.81
3375	909	2.65	955	2.99	1000	3.34	1041	3.70	1081	4.06
3563	927	2.88	973	3.23	1017	3.59	1059	3.96	1098	4.34
3750	946	3.12	992	3.48	1035	3.86	1076	4.24	1115	4.63²

NOTE: For more information, see General Fan Performance Notes.

Boldface indicates field – supplied drive is required.

1. Recommend using field – supplied fan pulley (part no. KR11AK012), motor pulley (part no. KR11HY161) and belt (part no. KR30AE035).
2. Recommend using field – supplied fan pulley (part no. KR11AZ002) and belt (part no. KR29AF054).

Table 8 (cont.) 50TC**08

3 PHASE

7.5 TON VERTICAL SUPPLY

CFM	AVAILABLE EXTERNAL STATIC PRESSURE (IN. WG)									
	0.2		0.4		0.6		0.8		1.0	
	RPM	BHP	RPM	BHP	RPM	BHP	RPM	BHP	RPM	BHP
	Standard Static Option						Medium Static Option			
2250	511	0.53	591	0.73	660	0.95	722	1.19	779	1.44
2438	540	0.64	616	0.85	683	1.08	743	1.33	799	1.59
2625	569	0.76	642	0.99	706	1.23	765	1.49	819	1.76
2813	599	0.90	669	1.14	731	1.39	788	1.66	841	1.94
3000	630	1.06	696	1.31	756	1.58	811	1.86	863	2.15
3188	661	1.23	724	1.50	782	1.78	836	2.07	886	2.38
3375	692	1.43	753	1.71	809	2.00	861	2.31	910	2.62
3563	723	1.65	782	1.94	836	2.25	887	2.56	934	2.89
3750	755	1.89	811	2.20	864	2.52	913	2.84	959	3.18

CFM	AVAILABLE EXTERNAL STATIC PRESSURE (IN. WG)									
	1.2		1.4		1.6		1.8		2.0	
	RPM	BHP	RPM	BHP	RPM	BHP	RPM	BHP	RPM	BHP
	Medium Static Option						High Static Option			
2250	832	1.71	882	1.99	928	2.29	973	2.59	1015	2.92
2438	851	1.87	899	2.16	945	2.46	989	2.78	1031	3.11
2625	870	2.04	918	2.34	963	2.66	1006	2.98	1048	3.32
2813	890	2.24	937	2.55	982	2.87	1024	3.21	1065	3.55
3000	912	2.46	958	2.78	1001	3.11	1043	3.45	1083	3.80
3188	934	2.69	979	3.02	1022	3.36	1063	3.72	1102	4.08
3375	956	2.95	1000	3.29	1042	3.64	1083	4.00	1122	4.38
3563	980	3.23	1023	3.58	1064	3.94	1104	4.32	1142	4.70
3750	1004	3.54	1046	3.90	1086	4.27	1125	4.65	–	–

NOTE: For more information, see General Fan Performance Notes.

Boldface indicates field – supplied drive is required.

1. Recommend using field – supplied fan pulley (part no. KR11AZ002) and belt (part no. KR29AF054).

FAN PERFORMANCE (cont.)

Table 8 (cont.) 50TC**09

3 PHASE

8.5 TON HORIZONTAL SUPPLY

CFM	AVAILABLE EXTERNAL STATIC PRESSURE (IN. WG)									
	0.2		0.4		0.6		0.8		1.0	
	RPM	BHP	RPM	BHP	RPM	BHP	RPM	BHP	RPM	BHP
	Field Supplied Drive¹		Standard Static Option							
2550	438	0.39	523	0.50	595	0.64	658	0.78	716	0.94
2763	459	0.47	541	0.60	611	0.73	673	0.88	730	1.05
2975	481	0.56	560	0.70	628	0.84	689	1.00	745	1.16
3188	504	0.67	580	0.82	646	0.97	705	1.13	760	1.30
3400	526	0.80	600	0.95	664	1.11	722	1.27	776	1.45
3613	550	0.94	620	1.10	683	1.26	740	1.43	793	1.62
3825	573	1.09	641	1.26	702	1.43	758	1.61	810	1.80
4038	597	1.26	663	1.44	722	1.62	777	1.81	827	2.00
4250	621	1.45	685	1.64	743	1.83	796	2.02	845	2.22

CFM	AVAILABLE EXTERNAL STATIC PRESSURE (IN. WG)									
	1.2		1.4		1.6		1.8		2.0	
	RPM	BHP	RPM	BHP	RPM	BHP	RPM	BHP	RPM	BHP
	Medium Static Option						High Static Option			
2550	769	1.11	819	1.30	865	1.49	909	1.70	951	1.92
2763	782	1.22	831	1.41	877	1.60	921	1.81	963	2.04
2975	796	1.34	845	1.53	890	1.73	933	1.94	974	2.16
3188	811	1.48	858	1.67	903	1.88	946	2.09	987	2.31
3400	826	1.63	873	1.83	917	2.04	959	2.25	1000	2.48
3613	842	1.81	888	2.01	932	2.22	973	2.44	1013	2.67
3825	858	2.00	903	2.20	946	2.42	988	2.64	1027	2.87
4038	875	2.20	919	2.41	962	2.63	1002	2.86	1041	3.10
4250	892	2.43	936	2.65	978	2.87	1018	3.10	1056	3.34

NOTE: For more information, see General Fan Performance Notes.

Boldface indicates field – supplied drive is required.

1. Recommend using field – supplied fan pulley (part no. KR11AK012) and belt (part no. KR30AE055).

Table 8 (cont.) 50TC**09

3 PHASE

8.5 VERTICAL SUPPLY

CFM	AVAILABLE EXTERNAL STATIC PRESSURE (IN. WG)									
	0.2		0.4		0.6		0.8		1.0	
	RPM	BHP	RPM	BHP	RPM	BHP	RPM	BHP	RPM	BHP
	Field Supplied Drive¹		Standard Static Option						Medium Static Option	
2550	477	0.43	556	0.57	624	0.71	685	0.85	742	0.99
2763	503	0.52	578	0.67	644	0.82	704	0.97	759	1.13
2975	529	0.62	601	0.79	665	0.95	724	1.11	777	1.28
3188	556	0.74	625	0.92	687	1.09	744	1.26	796	1.44
3400	583	0.88	650	1.06	710	1.24	765	1.43	816	1.62
3613	611	1.03	675	1.22	733	1.42	787	1.61	836	1.81
3825	639	1.19	701	1.40	757	1.61	809	1.81	857	2.02
4038	668	1.38	727	1.60	781	1.81	832	2.03	879	2.25
4250	696	1.58	753	1.81	806	2.04	855	2.27	901	2.50

CFM	AVAILABLE EXTERNAL STATIC PRESSURE (IN. WG)									
	1.2		1.4		1.6		1.8		2.0	
	RPM	BHP	RPM	BHP	RPM	BHP	RPM	BHP	RPM	BHP
	Medium Static Option						High Static Option			
2550	794	1.14	842	1.29	888	1.44	932	1.59	973	1.75
2763	810	1.28	858	1.44	903	1.60	946	1.77	987	1.93
2975	827	1.44	874	1.61	919	1.78	961	1.95	1001	2.13
3188	845	1.62	891	1.79	935	1.98	977	2.16	1017	2.34
3400	864	1.80	909	1.99	952	2.18	993	2.38	1033	2.57
3613	883	2.01	928	2.21	970	2.41	1010	2.61	1049	2.82
3825	903	2.23	947	2.44	988	2.65	1028	2.87	1066	3.08
4038	924	2.47	967	2.70	1008	2.92	1047	3.14	1084	3.37
4250	945	2.73	987	2.97	1027	3.20	1066	3.43	1103	3.67²

NOTE: For more information, see General Fan Performance Notes.

Boldface indicates field – supplied drive is required.

1. Recommend using field – supplied fan pulley (part no. KR11AK012) and belt (part no. KR29AE055).
2. Recommend using field – supplied fan pulley (part no. KR11AZ002), motor pulley (part no. KR11HY310) and belt (part no. KR29AF054).

FAN PERFORMANCE (cont.)

Table 8 (cont.) 50TC**12

3 PHASE

10 TON HORIZONTAL SUPPLY

CFM	AVAILABLE EXTERNAL STATIC PRESSURE (IN. WG)									
	0.2		0.4		0.6		0.8		1.0	
	RPM	BHP	RPM	BHP	RPM	BHP	RPM	BHP	RPM	BHP
	Field Supplied Drive¹		Standard Static Option							
3000	523	0.58	592	0.73	657	0.88	718	1.05	775	1.22
3250	555	0.71	620	0.87	681	1.04	739	1.21	794	1.39
3500	588	0.86	649	1.03	707	1.21	762	1.39	815	1.58
3750	621	1.03	679	1.21	734	1.40	786	1.59	837	1.79
4000	655	1.23	709	1.42	761	1.61	812	1.82	860	2.03
4250	689	1.45	741	1.65	790	1.86	838	2.07	885	2.29
4500	723	1.69	773	1.90	820	2.12	866	2.35	910	2.57
4750	758	1.96	805	2.19	850	2.42	894	2.65	937	2.89
5000	793	2.26	838	2.50	881	2.74	923	2.98	965	3.23

CFM	AVAILABLE EXTERNAL STATIC PRESSURE (IN. WG)									
	1.2		1.4		1.6		1.8		2.0	
	RPM	BHP	RPM	BHP	RPM	BHP	RPM	BHP	RPM	BHP
	Standard Static Opt.		Medium Static Option							
3000	830	1.39	883	1.57	934	1.76	982	1.95	1029	2.14
3250	847	1.57	897	1.76	946	1.96	993	2.16	1039	2.36
3500	865	1.77	914	1.97	961	2.18	1007	2.38	1051	2.60
3750	885	1.99	932	2.20	978	2.42	1022	2.64	1065	2.86
4000	907	2.24	952	2.46	996	2.68	1038	2.91	1080	3.14
4250	930	2.51	973	2.74	1015	2.97	1057	3.21	1097	3.45
4500	954	2.81	996	3.05	1037	3.29	1076	3.54	1115	3.79
4750	979	3.13	1019	3.38	1059	3.63	1097	3.89	1135	4.15
5000	1005	3.49	1044	3.74	1082	4.01	1119	4.27	1156	4.55

NOTE: For more information, see General Fan Performance Notes.

Boldface indicates field-supplied drive is required.

1. Recommend using field-supplied fan pulley (part no. KR11AD912) and belt (part no. KR29AF051).

Table 8 (cont.) 50TC**12

3 PHASE

10 VERTICAL SUPPLY

CFM	AVAILABLE EXTERNAL STATIC PRESSURE (IN. WG)									
	0.2		0.4		0.6		0.8		1.0	
	RPM	BHP	RPM	BHP	RPM	BHP	RPM	BHP	RPM	BHP
	Field Supplied Drive¹		Standard Static Option							
3000	556	0.65	623	0.80	684	0.95	738	1.11	789	1.26
3250	590	0.79	655	0.96	713	1.13	766	1.29	815	1.46
3500	625	0.96	687	1.14	742	1.32	794	1.50	841	1.68
3750	661	1.16	719	1.35	773	1.54	822	1.73	869	1.93
4000	697	1.37	753	1.58	804	1.79	852	1.99	897	2.20
4250	733	1.62	787	1.84	836	2.06	883	2.28	926	2.49
4500	770	1.89	821	2.13	869	2.36	914	2.59	956	2.82
4750	807	2.20	856	2.45	902	2.69	945	2.94	986	3.18
5000	844	2.54	891	2.80	936	3.06	978	3.31	1018	3.57

CFM	AVAILABLE EXTERNAL STATIC PRESSURE (IN. WG)									
	1.2		1.4		1.6		1.8		2.0	
	RPM	BHP	RPM	BHP	RPM	BHP	RPM	BHP	RPM	BHP
	Medium Static Option									
3000	836	1.42	881	1.57	923	1.73	963	1.89	1001	2.05
3250	861	1.63	904	1.79	945	1.96	985	2.13	1023	2.30
3500	886	1.86	929	2.04	969	2.22	1008	2.40	1045	2.58
3750	912	2.12	954	2.31	994	2.50	1031	2.70	1068	2.89
4000	940	2.40	980	2.61	1019	2.81	1056	3.02	1092	3.22
4250	968	2.71	1007	2.93	1045	3.15	1081	3.36	1117	3.58
4500	996	3.05	1035	3.28	1072	3.51	1108	3.74	1142	3.97
4750	1026	3.42	1063	3.66	1100	3.91	1135	4.15	1168	4.39
5000	1056	3.82	1093	4.08	1128	4.34	1162	4.59	-	-

NOTE: For more information, see General Fan Performance Notes.

Boldface indicates field-supplied drive is required.

1. Recommend using field-supplied fan pulley (part no. KR11AD912) and belt (part no. KR29AF051).

FAN PERFORMANCE (cont.)

Table 8 (cont.) 50TC14**

3 PHASE

12.5 TON HORIZONTAL SUPPLY

CFM	AVAILABLE EXTERNAL STATIC PRESSURE (IN. WG)									
	0.2		0.4		0.6		0.8		1.0	
	RPM	BHP	RPM	BHP	RPM	BHP	RPM	BHP	RPM	BHP
	Field Supplied Drive¹		Standard Static Option							
3438	580	0.82	642	0.99	700	1.16	756	1.34	809	1.53
3750	621	1.03	679	1.21	734	1.40	786	1.59	837	1.79
4063	663	1.28	717	1.47	769	1.67	818	1.88	866	2.09
4375	706	1.56	757	1.77	805	1.98	852	2.20	897	2.43
4688	749	1.89	797	2.11	843	2.34	887	2.57	930	2.81
5000	793	2.26	838	2.50	881	2.74	923	2.98	965	3.23
5313	837	2.69	880	2.93	921	3.19	961	3.44	1000	3.71
5625	882	3.16	922	3.42	961	3.68	999	3.95	1037	4.23
5938	926	3.68	964	3.96	1001	4.23	1038	4.52	-	-
6250	971	4.26	1007	4.55	-	-	-	-	-	-

CFM	AVAILABLE EXTERNAL STATIC PRESSURE (IN. WG)									
	1.2		1.4		1.6		1.8		2.0	
	RPM	BHP	RPM	BHP	RPM	BHP	RPM	BHP	RPM	BHP
	Medium Static Option									
3438	860	1.72	910	1.92	957	2.12	1003	2.32	1048	2.54
3750	885	1.99	932	2.20	978	2.42	1022	2.64	1065	2.86
4063	912	2.31	957	2.53	1001	2.75	1043	2.98	1084	3.22
4375	941	2.66	984	2.89	1026	3.13	1066	3.37	1106	3.62
4688	972	3.05	1013	3.29	1053	3.54	1092	3.80	1130	4.06
5000	1005	3.49	1044	3.74	1082	4.01	1119	4.27	1156	4.55
5313	1038	3.97	1076	4.24	1113	4.52	-	-	-	-
5625	1073	4.51	-	-	-	-	-	-	-	-
5938	-	-	-	-	-	-	-	-	-	-
6250	-	-	-	-	-	-	-	-	-	-

NOTE: For more information, see General Fan Performance Notes.

Boldface indicates field-supplied drive is required.

1. Recommend using field-supplied fan pulley (part no. KR11AK012) and belt (part no. KR29AE055).
2. Recommend using field-supplied fan pulley (part no. KR11AZ002), motor pulley (part no. KR11HY310) and belt (part no. KR29AF054).

Table 8 (cont.) 50TC14**

3 PHASE

12.5 TON VERTICAL SUPPLY

CFM	AVAILABLE EXTERNAL STATIC PRESSURE (IN. WG)									
	0.2		0.4		0.6		0.8		1.0	
	RPM	BHP	RPM	BHP	RPM	BHP	RPM	BHP	RPM	BHP
	Field Supplied Drive¹		Standard Static Option							
3438	616	0.92	679	1.10	735	1.27	786	1.45	835	1.62
3750	661	1.16	719	1.35	773	1.54	822	1.73	869	1.93
4063	706	1.43	761	1.64	812	1.85	860	2.06	904	2.27
4375	752	1.75	804	1.98	852	2.20	898	2.43	941	2.65
4688	798	2.12	847	2.36	894	2.60	937	2.85	979	3.09
5000	844	2.54	891	2.80	936	3.06	978	3.31	1018	3.57
5313	891	3.01	936	3.28	978	3.56	1019	3.83	1057	4.11
5625	938	3.53	981	3.83	1022	4.12	1060	4.41	1097	4.70
5938	986	4.12	1026	4.43	-	-	-	-	-	-
6250	-	-	-	-	-	-	-	-	-	-

CFM	AVAILABLE EXTERNAL STATIC PRESSURE (IN. WG)									
	1.2		1.4		1.6		1.8		2.0	
	RPM	BHP	RPM	BHP	RPM	BHP	RPM	BHP	RPM	BHP
	Medium Static Option									
3438	880	1.80	922	1.98	963	2.15	1002	2.33	1039	2.51
3750	912	2.12	954	2.31	994	2.50	1031	2.70	1068	2.89
4063	947	2.48	987	2.68	1025	2.89	1062	3.10	1098	3.31
4375	982	2.88	1021	3.10	1058	3.32	1094	3.55	1129	3.77
4688	1018	3.33	1056	3.57	1093	3.81	1128	4.04	1162	4.29
5000	1056	3.82	1093	4.08	1128	4.34	1162	4.59	-	-
5313	1094	4.38	1130	4.65	-	-	-	-	-	-
5625	-	-	-	-	-	-	-	-	-	-
5938	-	-	-	-	-	-	-	-	-	-
6250	-	-	-	-	-	-	-	-	-	-

NOTE: For more information, see General Fan Performance Notes.

Boldface indicates field-supplied drive is required.

1. Recommend using field-supplied fan pulley (part no. KR11AK012) and belt (part no. KR29AE055).
2. Recommend using field-supplied fan pulley (part no. KR11AZ002), motor pulley (part no. KR11HY310) and belt (part no. KR29AF054).

FAN PERFORMANCE (cont.)

Table 8 (cont.) 50TC16**

3 PHASE

15 TON VERTICAL SUPPLY

CFM	Available External Static Pressure (in. wg)									
	0.2		0.4		0.6		0.8		1.0	
	RPM	BHP	RPM	BHP	RPM	BHP	RPM	BHP	RPM	BHP
4500	425	0.76	490	1.02	550	1.30	607	1.61	664	1.96
4875	448	0.92	510	1.20	566	1.49	621	1.81	674	2.15
5250	472	1.10	531	1.40	584	1.70	636	2.03	686	2.38
5625	496	1.30	552	1.62	603	1.94	652	2.28	699	2.64
6000	520	1.52	574	1.86	623	2.20	670	2.55	715	2.92
6375	544	1.77	596	2.13	644	2.49	688	2.86	731	3.24
6750	568	2.05	618	2.43	664	2.81	707	3.19	749	3.59
7125	593	2.35	641	2.75	685	3.16	727	3.56	767	3.97
7500	617	2.69	664	3.11	707	3.53	747	3.95	786	4.38

CFM	Available External Static Pressure (in. wg)									
	1.2		1.4		1.6		1.8		2.0	
	RPM	BHP	RPM	BHP	RPM	BHP	RPM	BHP	RPM	BHP
4500	719	2.34	772	2.76	823	3.20	872	3.67	918	4.16
4875	725	2.54	776	2.95	825	3.40	873	3.87	919	4.37
5250	734	2.76	783	3.18	830	3.63	876	4.10	920	4.60
5625	746	3.03	791	3.44	836	3.89	880	4.36	923	4.86
6000	759	3.32	802	3.74	845	4.18	887	4.66	928	5.16
6375	773	3.64	814	4.07	855	4.52	895	4.99	935	5.49
6750	789	4.00	828	4.43	867	4.89	905	5.36	943	5.87
7125	806	4.39	844	4.84	881	5.29	917	5.78	-	-
7500	823	4.82	860	5.27	895	5.74	-	-	-	-

NOTE: For more information, see General Fan Performance Notes.

Table 8 (cont.) 50TC16**

3 PHASE

15 TON HORIZONTAL SUPPLY

CFM	Available External Static Pressure (in. wg)									
	0.2		0.4		0.6		0.8		1.0	
	RPM	BHP	RPM	BHP	RPM	BHP	RPM	BHP	RPM	BHP
4500	423	0.77	487	0.99	545	1.22	601	1.47	655	1.73
4875	447	0.94	507	1.18	563	1.42	615	1.67	666	1.95
5250	471	1.13	528	1.38	581	1.64	631	1.91	679	2.19
5625	496	1.35	550	1.62	600	1.89	648	2.17	694	2.46
6000	520	1.59	572	1.88	620	2.17	666	2.46	710	2.76
6375	545	1.86	594	2.17	640	2.47	684	2.78	726	3.10
6750	571	2.17	617	2.48	661	2.81	704	3.13	744	3.46
7125	596	2.50	640	2.83	683	3.17	724	3.52	763	3.86
7500	622	2.87	663	3.22	705	3.58	744	3.93	782	4.30

CFM	Available External Static Pressure (in. wg)									
	1.2		1.4		1.6		1.8		2.0	
	RPM	BHP	RPM	BHP	RPM	BHP	RPM	BHP	RPM	BHP
4500	707	2.02	758	2.33	806	2.66	853	3.01	898	3.37
4875	716	2.24	764	2.55	811	2.89	856	3.24	900	3.61
5250	726	2.49	772	2.81	817	3.14	860	3.50	903	3.87
5625	738	2.77	782	3.09	825	3.43	867	3.79	908	4.17
6000	752	3.08	794	3.41	835	3.76	875	4.12	914	4.50
6375	767	3.42	807	3.76	846	4.12	885	4.49	923	4.87
6750	784	3.80	822	4.15	859	4.51	896	4.89	933	5.28
7125	801	4.22	838	4.58	874	4.95	909	5.33	944	5.73
7500	818	4.66	854	5.04	889	5.42	923	5.81	-	-

NOTE: For more information, see General Fan Performance Notes.

FAN PERFORMANCE (cont.)

Table 9 – PULLEY ADJUSTMENT

UNIT	MOTOR/DRIVE COMBO	MOTOR PULLEY TURNS OPEN											
		0.0	0.5	1.0	1.5	2.0	2.5	3.0	3.5	4.0	4.5	5.0	
04	1 phase	Standard Static	854	825	795	766	736	707	678	648	619	589	560
		Medium Static	1175	1135	1094	1054	1013	973	932	892	851	811	770
		High Static	–	–	–	–	–	–	–	–	–	–	–
	3 phase	Standard Static	854	825	795	766	736	707	678	648	619	589	560
		Medium Static	1175	1135	1094	1054	1013	973	932	892	851	811	770
		High Static	1466	1423	1380	1337	1294	1251	1207	1164	1121	1078	1035
05	1 phase	Standard Static	854	825	795	766	736	707	678	648	619	589	560
		Medium Static	1175	1135	1094	1054	1013	973	932	892	851	811	770
		High Static	–	–	–	–	–	–	–	–	–	–	–
	3 phase	Standard Static	854	825	795	766	736	707	678	648	619	589	560
		Medium Static	1175	1135	1094	1054	1013	973	932	892	851	811	770
		High Static	1466	1423	1380	1337	1294	1251	1207	1164	1121	1078	1035
06	1 phase	Standard Static	1175	1135	1094	1054	1013	973	932	892	851	811	770
		Medium Static	1466	1423	1380	1337	1294	1251	1207	1164	1121	1078	1035
		High Static	–	–	–	–	–	–	–	–	–	–	–
	3 phase	Standard Static	1175	1135	1094	1054	1013	973	932	892	851	811	770
		Medium Static	1466	1423	1380	1337	1294	1251	1207	1164	1121	1078	1035
		High Static	1687	1649	1610	1572	1533	1495	1457	1418	1380	1341	1303
07	3 phase	Standard Static	1457	1419	1380	1342	1303	1265	1227	1188	1150	1111	1073
		Medium Static	1518	1484	1449	1415	1380	1346	1311	1277	1242	1208	1173
		High Static	1788	1757	1725	1694	1662	1631	1600	1568	1537	1505	1474
08	3 phase	Standard Static	747	721	695	670	644	618	592	566	541	515	489
		Medium Static	949	927	906	884	863	841	819	798	776	755	733
		High Static	1102	1083	1063	1044	1025	1006	986	967	948	928	909
09	3 phase	Standard Static	733	712	690	669	647	626	604	583	561	540	518
		Medium Static	936	911	887	862	838	813	788	764	739	715	690
		High Static	1084	1059	1035	1010	986	961	936	912	887	863	838
12	3 phase	Standard Static	838	813	789	764	739	715	690	665	640	616	591
		Medium Static	1084	1059	1035	1010	986	961	936	912	887	863	838
		High Static	1240	1218	1196	1175	1153	1131	1109	1087	1066	1044	1022
14	3 phase	Standard Static	843	824	805	786	767	748	728	709	690	671	652
		Medium Static	1084	1059	1035	1010	986	961	936	912	887	863	838
		High Static	1240	1218	1196	1175	1153	1131	1109	1087	1066	1044	1022
16	3 phase	Standard Static	676	659	642	625	608	592	575	558	541	524	507
		Medium Static	851	829	806	784	761	739	717	694	672	649	627
		High Static	955	937	919	901	883	866	848	830	812	794	776

NOTE: Do not adjust pulley further than 5 turns open.

■ – Factory settings

ELECTRICAL DATA FOR UNITS PRODUCED ON OR AFTER JULY 30, 2012

NOTE: Check the serial number of unit to verify production date.

To confirm the date of manufacture, locate the unit nameplate and check the first four digits of the Serial Number. If the number listed in the first 4 digits of the Serial Number is 3112 or higher, the unit was produced on or after July 30, 2012.

Position:	1	2	3	4	5	6	7	8	9	10
Example:	3	1	1	2	U	1	2	3	4	5

Week of manufacture (fiscal calendar)			Sequence number
Year of manufacture ("12" = 2012)		Manufacturing location	

C12562A

ELECTRICAL INFORMATION
(UNITS PRODUCED ON OR AFTER JULY 30, 2012)

Table 10 – 50TC04 1-STAGE COOLING WITH 1-SPEED INDOOR FAN MOTOR 3 TONS**

V-Ph-Hz	VOLTAGE RANGE		COMP (ea)		OFM (ea)		IFM		
	MIN	MAX	RLA	LRA	WATTS	FLA	TYPE	EFF at Full Load	FLA
208-1-60	187	253	16.6	79	325	1.5	STD	67%	4.9
					325	1.5	MED	67%	4.9
230-1-60	187	253	16.6	79	325	1.5	STD	67%	4.9
					325	1.5	MED	67%	4.9
208-3-60	187	253	10.4	73	325	1.5	STD	75%	5.2
					325	1.5	MED	75%	5.2
					325	1.5	HIGH	87%	6.9
230-3-60	187	253	10.4	73	325	1.5	STD	75%	5.2
					325	1.5	MED	75%	5.2
					325	1.5	HIGH	87%	6.7
460-3-60	414	506	5.8	38	325	0.8	STD	75%	2.6
					325	0.8	MED	75%	2.6
					325	0.8	HIGH	87%	3.4
575-3-60	518	633	3.8	37	325	0.6	STD	73%	2.4
					325	0.6	MED	73%	2.4
					325	0.6	HIGH	78%	2.0

Table 10 (cont.) - 50TC05 1-STAGE COOLING WITH 1-SPEED INDOOR FAN MOTOR 4 TONS**

V-Ph-Hz	VOLTAGE RANGE		COMP (ea)		OFM (ea)		IFM		
	MIN	MAX	RLA	LRA	WATTS	FLA	TYPE	EFF at Full Load	FLA
208-1-60	187	253	21.8	117	325	1.5	STD	67%	4.9
					325	1.5	MED	67%	4.9
230-1-60	187	253	21.8	117	325	1.5	STD	67%	4.9
					325	1.5	MED	67%	4.9
208-3-60	187	253	13.7	83	325	1.5	STD	75%	5.2
					325	1.5	MED	75%	5.2
					325	1.5	HIGH	87%	6.9
230-3-60	187	253	13.7	83	325	1.5	STD	75%	5.2
					325	1.5	MED	75%	5.2
					325	1.5	HIGH	87%	6.7
460-3-60	414	506	6.2	41	325	0.8	STD	75%	2.6
					325	0.8	MED	75%	2.6
					325	0.8	HIGH	87%	3.4
575-3-60	518	633	4.8	33	325	0.6	STD	73%	2.4
					325	0.6	MED	73%	2.4
					325	0.6	HIGH	78%	2.0

Table 10 (cont.) - 50TC06 1-STAGE COOLING WITH 1-SPEED INDOOR FAN MOTOR 5 TONS**

V-Ph-Hz	VOLTAGE RANGE		COMP (ea)		OFM (ea)		IFM		
	MIN	MAX	RLA	LRA	WATTS	FLA	TYPE	EFF at Full Load	FLA
208-1-60	187	253	26.2	134	325	1.5	STD	67%	4.9
					325	1.5	MED	76%	7.0
230-1-60	187	253	26.2	134	325	1.5	STD	67%	4.9
					325	1.5	MED	76%	7.0
208-3-60	187	253	15.6	110	325	1.5	STD	75%	5.2
					325	1.5	MED	87%	6.9
					325	1.5	HIGH	89%	8.4
230-3-60	187	253	15.6	110	325	1.5	STD	75%	5.2
					325	1.5	MED	87%	6.7
					325	1.5	HIGH	89%	8.3
460-3-60	414	506	7.7	52	325	0.8	STD	75%	2.6
					325	0.8	MED	87%	3.4
					325	0.8	HIGH	89%	4.2
575-3-60	518	633	5.8	39	325	0.6	STD	73%	2.4
					325	0.6	MED	78%	2.0
					325	0.6	HIGH	77%	2.8

ELECTRICAL INFORMATION
(UNITS PRODUCED ON OR AFTER JULY 30, 2012) cont.

Table 10 (cont.) - 50TC07 1-STAGE COOLING WITH 1-SPEED INDOOR FAN MOTOR**

6 TONS

V-Ph-Hz	VOLTAGE RANGE		COMP (ea)		OFM (ea)		IFM		
	MIN	MAX	RLA	LRA	WATTS	FLA	TYPE	EFF at Full Load	FLA
208-3-60	187	253	19.0	123	325	1.5	STD	87%	6.9
					325	1.5	MED	89%	8.4
					325	1.5	HIGH	87%	10.6
230-3-60	187	253	19.0	123	325	1.5	STD	87%	6.7
					325	1.5	MED	89%	8.3
					325	1.5	HIGH	87%	10.6
460-3-60	414	506	9.7	62	325	0.8	STD	87%	3.4
					325	0.8	MED	89%	4.2
					325	0.8	HIGH	87%	5.3
575-3-60	518	633	7.4	50	325	0.6	STD	78%	2.0
					325	0.6	MED	77%	2.8
					325	0.6	HIGH	77%	2.8

Table 10 (cont.) - 50TC08 1-STAGE COOLING WITH 1-SPEED INDOOR FAN MOTOR**

7.5 TONS

V-Ph-Hz	VOLTAGE RANGE		COMP (ea)		OFM (ea)		IFM		
	MIN	MAX	RLA	LRA	WATTS	FLA	TYPE	EFF at Full Load	FLA
208-3-60	187	253	25.0	164	325	1.5	STD	87%	5.2
					325	1.5	MED	89%	8.4
					325	1.5	HIGH	83%	13.6
230-3-60	187	253	25.0	164	325	1.5	STD	87%	4.9
					325	1.5	MED	89%	8.3
					325	1.5	HIGH	83%	12.7
460-3-60	414	506	12.2	100	325	0.8	STD	87%	2.5
					325	0.8	MED	89%	4.2
					325	0.8	HIGH	83%	6.4
575-3-60	518	633	9.0	78	325	0.6	STD	72%	1.6
					325	0.6	MED	77%	2.8
					325	0.6	HIGH	81%	5.6

Table 10 (cont.) - 50TCD08 2-STAGE COOLING WITH 1-SPEED INDOOR FAN MOTOR**

7.5 TONS

V-Ph-Hz	VOLTAGE RANGE		COMP (Cir 1)		COMP (Cir 2)		OFM (ea)		IFM		
	MIN	MAX	RLA	LRA	RLA	LRA	WATTS	FLA	TYPE	EFF at Full Load	FLA
208-3-60	187	253	13.6	83	13.6	83	325	1.5	STD	87%	5.2
							325	1.5	MED	89%	8.4
							325	1.5	HIGH	83%	13.6
230-3-60	187	253	13.6	83	13.6	83	325	1.5	STD	87%	4.9
							325	1.5	MED	89%	8.3
							325	1.5	HIGH	83%	12.7
460-3-60	414	506	6.1	41	6.1	41	325	0.8	STD	87%	2.5
							325	0.8	MED	89%	4.2
							325	0.8	HIGH	83%	6.4
575-3-60	518	633	4.2	33	4.2	33	325	0.6	STD	72%	1.6
							325	0.6	MED	77%	2.8
							325	0.6	HIGH	81%	5.6

ELECTRICAL INFORMATION
(UNITS PRODUCED ON OR AFTER JULY 30, 2012) cont.

Table 10 (cont.) - 50TC*D08 2-STAGE COOLING WITH 2 SPEED INDOOR FAN MOTOR

7.5 TONS

V-Ph-Hz	VOLTAGE RANGE		COMP 1		COMP 2		OFM (ea)		IFM		
	MIN	MAX	RLA	LRA	RLA	LRA	WATTS	FLA	TYPE	EFF at Full Load	FLA
208-3-60	187	253	13.6	83	13.6	83	325	1.5	STD	0.84	5.8
							325	1.5	MED	0.85	8.6
							325	1.5	HIGH	0.84	13.6
230-3-60	187	253	13.6	83	13.6	83	325	1.5	STD	0.84	5.6
							325	1.5	MED	0.85	7.8
							325	1.5	HIGH	0.84	12.7
460-3-60	414	506	6.1	41	6.1	41	325	0.8	STD	0.79	2.9
							325	0.8	MED	0.85	3.8
							325	0.8	HIGH	0.84	6.4
575-3-60	518	633	4.2	33	4.2	33	325	0.6	STD	0.81	2.8
							325	0.6	MED	0.84	4.5
							325	0.6	HIGH	0.83	6.2

Table 10 (cont.) - 50TC09 1-STAGE COOLING WITH 1-SPEED INDOOR FAN MOTOR**

8.5 TONS

V-Ph-Hz	VOLTAGE RANGE		COMP (ea)		OFM (ea)		IFM		
	MIN	MAX	RLA	LRA	WATTS	FLA	TYPE	EFF at Full Load	FLA
208-3-60	187	253	29.5	195	325	1.5	STD	87%	5.2
					325	1.5	MED	87%	6.9
					325	1.5	HIGH	87%	10.6
230-3-60	187	253	29.5	195	325	1.5	STD	87%	4.9
					325	1.5	MED	87%	6.7
					325	1.5	HIGH	87%	10.6
460-3-60	414	506	14.7	95	325	0.8	STD	87%	2.5
					325	0.8	MED	87%	3.4
					325	0.8	HIGH	87%	5.3
575-3-60	518	633	12.2	80	325	0.6	STD	72%	1.6
					325	0.6	MED	78%	2.0
					325	0.6	HIGH	77%	2.8

Table 10 (cont.) - 50TC09 2-STAGE COOLING WITH 1-SPEED INDOOR FAN MOTOR**

8.5 TONS

V-Ph-Hz	VOLTAGE RANGE		COMP (Cir 1)		COMP (Cir 2)		OFM (ea)		IFM		
	MIN	MAX	RLA	LRA	RLA	LRA	WATTS	FLA	TYPE	EFF at Full Load	FLA
208-3-60	187	253	14.5	98	13.7	83	325	1.5	STD	87%	5.2
							325	1.5	MED	87%	6.9
							325	1.5	HIGH	87%	10.6
230-3-60	187	253	14.5	98	13.7	83	325	1.5	STD	87%	4.9
							325	1.5	MED	87%	6.7
							325	1.5	HIGH	87%	10.6
460-3-60	414	506	6.3	55	6.2	41	325	0.8	STD	87%	2.5
							325	0.8	MED	87%	3.4
							325	0.8	HIGH	87%	5.3
575-3-60	518	633	6.0	41	4.8	33	325	0.6	STD	72%	1.6
							325	0.6	MED	78%	2.0
							325	0.6	HIGH	77%	2.8

ELECTRICAL INFORMATION
(UNITS PRODUCED ON OR AFTER JULY 30, 2012) cont.

Table 10 (cont.) - 50TC*D09 2-STAGE COOLING WITH 2 SPEED INDOOR FAN MOTOR

8.5 TONS

V-Ph-Hz	VOLTAGE RANGE		COMP 1		COMP 2		OFM (ea)		IFM		
	MIN	MAX	RLA	LRA	RLA	LRA	WATTS	FLA	TYPE	EFF at Full Load	FLA
208-3-60	187	253	14.5	98	13.7	83	325	1.5	STD	0.84	5.8
							325	1.5	MED	0.77	7.1
							325	1.5	HIGH	0.82	10.8
230-3-60	187	253	14.5	98	13.7	83	325	1.5	STD	0.84	5.6
							325	1.5	MED	0.77	6.8
							325	1.5	HIGH	0.82	9.8
460-3-60	414	506	6.3	55	6.2	41	325	0.8	STD	0.79	2.9
							325	0.8	MED	0.77	3.8
							325	0.8	HIGH	0.82	4.9
575-3-60	518	633	6.0	41	4.8	33	325	0.6	STD	0.81	2.8
							325	0.6	MED	0.80	3.5
							325	0.6	HIGH	0.84	4.5

Table 10 (cont.) - 50TC12 1-STAGE COOLING WITH 1-SPEED INDOOR FAN MOTOR**

10 TONS

V-Ph-Hz	VOLTAGE RANGE		COMP (ea)		OFM (ea)		IFM		
	MIN	MAX	RLA	LRA	WATTS	FLA	TYPE	EFF at Full Load	FLA
208-3-60	187	253	30.1	225	325	1.5	STD	87%	6.9
					325	1.5	MED	87%	10.6
					325	1.5	HIGH	83%	13.6
230-3-60	187	253	30.1	225	325	1.5	STD	87%	6.7
					325	1.5	MED	87%	10.6
					325	1.5	HIGH	83%	12.7
460-3-60	414	506	16.7	114	325	0.8	STD	87%	3.4
					325	0.8	MED	87%	5.3
					325	0.8	HIGH	83%	6.4
575-3-60	518	633	12.2	80	325	0.6	STD	78%	2.0
					325	0.6	MED	77%	2.8
					325	0.6	HIGH	81%	5.6

Table 10 (cont.) - 50TC12 2-STAGE COOLING WITH 1-SPEED INDOOR FAN MOTOR**

10 TONS

V-Ph-Hz	VOLTAGE RANGE		COMP (Cir 1)		COMP (Cir 2)		OFM (ea)		IFM		
	MIN	MAX	RLA	LRA	RLA	LRA	WATTS	FLA	TYPE	EFF at Full Load	FLA
208-3-60	187	253	15.6	110	15.9	110	325	1.5	STD	87%	6.9
							325	1.5	MED	87%	10.6
							325	1.5	HIGH	83%	13.6
230-3-60	187	253	15.6	110	15.9	110	325	1.5	STD	87%	6.7
							325	1.5	MED	87%	10.6
							325	1.5	HIGH	83%	12.7
460-3-60	414	506	7.7	52	7.7	52	325	0.8	STD	87%	3.4
							325	0.8	MED	87%	5.3
							325	0.8	HIGH	83%	6.4
575-3-60	518	633	5.8	39	5.7	39	325	0.6	STD	78%	2.0
							325	0.6	MED	77%	2.8
							325	0.6	HIGH	81%	5.6

ELECTRICAL INFORMATION
(UNITS PRODUCED ON OR AFTER JULY 30, 2012) cont.

Table 10 (cont.) - 50TC*D12 2-STAGE COOLING WITH 2 SPEED INDOOR FAN MOTOR

10 TONS

V-Ph-Hz	VOLTAGE RANGE		COMP 1		COMP 2		OFM (ea)		IFM		
	MIN	MAX	RLA	LRA	RLA	LRA	WATTS	FLA	TYPE	EFF at Full Load	FLA
208-3-60	187	253	15.6	110	15.9	110	325	1.5	STD	0.77	7.1
							325	1.5	MED	0.82	10.8
							325	1.5	HIGH	0.84	13.6
230-3-60	187	253	15.6	110	15.9	110	325	1.5	STD	0.77	6.8
							325	1.5	MED	0.82	9.8
							325	1.5	HIGH	0.84	12.7
460-3-60	414	506	7.7	52	7.7	52	325	0.8	STD	0.77	3.8
							325	0.8	MED	0.82	4.9
							325	0.8	HIGH	0.84	6.4
575-3-60	518	633	5.8	39	5.7	39	325	0.6	STD	0.80	3.5
							325	0.6	MED	0.84	4.5
							325	0.6	HIGH	0.83	6.2

Table 10 (cont.) - 50TC14 2-STAGE COOLING WITH 1-SPEED INDOOR FAN MOTOR**

12.5 TONS

V-Ph-Hz	VOLTAGE RANGE		COMP (Cir 1)		COMP (Cir 2)		OFM (ea)		IFM		
	MIN	MAX	RLA	LRA	RLA	LRA	WATTS	FLA	TYPE	EFF at Full Load	FLA
208-3-60	187	253	19.0	123	22.4	149	1070	6.2	STD	89%	8.4
							1070	6.2	MED	87%	10.6
							1070	6.2	HIGH	83%	13.6
230-3-60	187	253	19.0	123	22.4	149	1070	6.2	STD	89%	8.3
							1070	6.2	MED	87%	10.6
							1070	6.2	HIGH	83%	12.7
460-3-60	414	506	9.7	62	10.6	75	1070	3.1	STD	89%	4.2
							1070	3.1	MED	87%	5.3
							1070	3.1	HIGH	83%	6.4
575-3-60	518	633	7.4	50	7.7	54	1070	2.5	STD	77%	2.8
							1070	2.5	MED	77%	2.8
							1070	2.5	HIGH	81%	5.6

Table 10 (cont.) - 50TC*D14 2-STAGE COOLING WITH 2 SPEED INDOOR FAN MOTOR

12.5 TONS

V-Ph-Hz	VOLTAGE RANGE		COMP 1		COMP 2		OFM (ea)		IFM		
	MIN	MAX	RLA	LRA	RLA	LRA	WATTS	FLA	TYPE	EFF at Full Load	FLA
208-3-60	187	253	19.0	123	22.4	149	1070	6.2	STD	0.85	8.6
							1070	6.2	MED	0.82	10.8
							1070	6.2	HIGH	0.84	13.6
230-3-60	187	253	19.0	123	22.4	149	1070	6.2	STD	0.85	7.8
							1070	6.2	MED	0.82	9.8
							1070	6.2	HIGH	0.84	12.7
460-3-60	414	506	9.7	62	10.6	75	1070	3.1	STD	0.85	3.8
							1070	3.1	MED	0.82	4.9
							1070	3.1	HIGH	0.84	6.4
575-3-60	518	633	7.4	50	7.7	54	1070	2.5	STD	0.84	4.5
							1070	2.5	MED	0.84	4.5
							1070	2.5	HIGH	0.83	6.2

ELECTRICAL INFORMATION
(UNITS PRODUCED ON OR AFTER JULY 30, 2012) cont.

Table 10 (cont.) - 50TC*D16 2-STAGE COOLING WITH 1-SPEED INDOOR FAN MOTOR

15 TONS

V-Ph-Hz	VOLTAGE RANGE		COMP (Cir 1)		COMP (Cir 2)		OFM (ea)		IFM		
	MIN	MAX	RLA	LRA	RLA	LRA	WATTS	FLA	TYPE	EFF at Full Load	FLA
208-3-60	187	253	25.0	164	25.0	164	280	1.5	STD	89%	8.4
							280	1.5	MED	87%	10.6
							280	1.5	HIGH	90%	20.4
230-3-60	187	253	25.0	164	25.0	164	280	1.5	STD	89%	8.3
							280	1.5	MED	87%	10.6
							280	1.5	HIGH	90%	20.4
460-3-60	414	506	12.2	100	12.8	100	280	0.8	STD	89%	4.2
							280	0.8	MED	87%	5.3
							280	0.8	HIGH	90%	10.2
575-3-60	518	633	9.8	78	9.6	78	280	0.6	STD	77%	2.8
							280	0.6	MED	77%	2.8
							280	0.6	HIGH	94%	9.0

Table 10 (cont.) - 50TC*D16 2-STAGE COOLING WITH 2 SPEED INDOOR FAN MOTOR

15 TONS

V-Ph-Hz	VOLTAGE RANGE		COMP 1		COMP 2		OFM (ea)		IFM		
	MIN	MAX	RLA	LRA	RLA	LRA	WATTS	FLA	TYPE	EFF at Full Load	FLA
208-3-60	187	253	25.0	164	25.0	164	280	1.5	STD	0.85	8.6
							280	1.5	MED	0.82	10.8
							280	1.5	HIGH	0.90	20.4
230-3-60	187	253	25.0	164	25.0	164	280	1.5	STD	0.85	7.8
							280	1.5	MED	0.82	9.8
							280	1.5	HIGH	0.90	20.4
460-3-60	414	506	12.2	100	12.8	100	280	0.8	STD	0.85	3.8
							280	0.8	MED	0.82	4.9
							280	0.8	HIGH	0.90	10.2
575-3-60	518	633	9.8	78	9.6	78	280	0.6	STD	0.84	4.5
							280	0.6	MED	0.84	4.5
							280	0.6	HIGH	0.94	9

ELECTRIC HEAT - ELECTRICAL INFORMATION (UNITS PRODUCED ON OR AFTER JULY 30, 2012)

Table 11 – 50TC04**

1-STAGE COOLING 1-SPEED INDOOR FAN MOTOR WITHOUT FACTORY INSTALLED NON-FUSED DISCONNECT

NOM. V-PH-Hz.	IFM TYPE	ELECTRIC HEATER PART NUMBER CRHEATERXXXXXX	NOM PWR (kW)	APP PWR (kW)	SINGLE POINT KIT PART NUMBER CRSINGLEXXXXXX			
					NO C.O. or UNPWRD C.O.		w/PWRD C.O.	
					NO P.E.	w/P.E. (pwrd fr/unit)	NO P.E.	w/P.E. (pwrd fr/unit)
208/ 230-1-60	STD	101A00	4.4	3.3/4.0	-	-	-	-
		102A00	6.5	4.9/6.0	-	-	-	-
		103B00	8.7	6.5/8.0	037	037	037	037
		104B00	10.5	7.9/9.6	040	040	040	040
		102A00,102A00	13.0	9.8/11.9	040	040	040	040
	MED	101A00	4.4	3.3/4.0	-	-	-	-
		102A00	6.5	4.9/6.0	-	-	-	-
		103B00	8.7	6.5/8.0	037	037	037	037
		104B00	10.5	7.9/9.6	040	040	040	040
		102A00,102A00	13.0	9.8/11.9	040	040	040	040
208/ 230-3-60	STD	101A00	4.4	3.3/4.0	-	-	-	-
		102A00	6.5	4.9/6.0	-	-	-	-
		103B00	8.7	6.5/8.0	-	-	-	-
		104B00	10.5	7.9/9.6	-	-	-	-
		105A00	16.0	12.0/14.7	037	037	038	038
	MED	101A00	4.4	3.3/4.0	-	-	-	-
		102A00	6.5	4.9/6.0	-	-	-	-
		103B00	8.7	6.5/8.0	-	-	-	-
		104B00	10.5	7.9/9.6	-	-	-	-
		105A00	16.0	12.0/14.7	037	037	038	038
	HIGH	101A00	4.4	3.3/4.0	-	-	-	-
		102A00	6.5	4.9/6.0	-	-	-	-
		103B00	8.7	6.5/8.0	-	-	-	-
		104B00	10.5	7.9/9.6	-	-	-	-
		105A00	16.0	12.0/14.7	037	037	038	038
460-3-60	STD	106A00	6.0	5.5	-	-	-	-
		107A00	8.8	8.1	-	-	-	-
		108A00	11.5	10.6	-	-	-	-
		109A00	14.0	12.9	-	-	-	-
	MED	106A00	6.0	5.5	-	-	-	-
		107A00	8.8	8.1	-	-	-	-
		108A00	11.5	10.6	-	-	-	-
		109A00	14.0	12.9	-	-	-	-
	HIGH	106A00	6.0	5.5	-	-	-	-
		107A00	8.8	8.1	-	-	-	-
		108A00	11.5	10.6	-	-	-	-
		109A00	14.0	12.9	-	-	-	-

LEGEND:

- APP PWR - 208 / 230V / 460V / 575V
- C.O. - Convenience outlet
- FLA - Full load amps
- IFM - Indoor fan motor
- NOM PWR - 240V / 480V / 600V
- P.E. - Power exhaust
- PWRD - Powered convenience outlet
- UNPWRD - Unpowered convenience outlet

ELECTRIC HEAT - ELECTRICAL INFORMATION (UNITS PRODUCED ON OR AFTER JULY 30, 2012)

Table 11 (cont.) - 50TC**04

1-STAGE COOLING 1-SPEED INDOOR FAN MOTOR WITH FACTORY INSTALLED NON-FUSED DISCONNECT

NOM. V-PH-Hz.	IFM TYPE	ELECTRIC HEATER PART NUMBER CRHEATERXXXXXX	NOM PWR (kW)	APP PWR (kW)	SINGLE POINT KIT PART NUMBER CRSINGLEXXXXXX			
					NO C.O. or UNPWRD C.O.		w/PWRD C.O.	
					NO P.E.	w/P.E. (pwr fr/unit)	NO P.E.	w/P.E. (pwr fr/unit)
208/ 230-1-60	STD	101A00	4.4	3.3/4.0	037	037	037	037
		102A00	6.5	4.9/6.0	037	037	037	037
		103B00	8.7	6.5/8.0	037	037	037	037
		104B00	10.5	7.9/9.6	040	040	040	040
		102A00,102A00	13.0	9.8/11.9	040	040	040	040
	MED	101A00	4.4	3.3/4.0	037	037	037	037
		102A00	6.5	4.9/6.0	037	037	037	037
		103B00	8.7	6.5/8.0	037	037	037	037
		104B00	10.5	7.9/9.6	040	040	040	040
		102A00,102A00	13.0	9.8/11.9	040	040	040	040
208/ 230-3-60	STD	101A00	4.4	3.3/4.0	037	037	037	037
		102A00	6.5	4.9/6.0	037	037	037	037
		103B00	8.7	6.5/8.0	037	037	037	037
		104B00	10.5	7.9/9.6	037	037	037	037
		105A00	16.0	12.0/14.7	037	037	038	038
	MED	101A00	4.4	3.3/4.0	037	037	037	037
		102A00	6.5	4.9/6.0	037	037	037	037
		103B00	8.7	6.5/8.0	037	037	037	037
		104B00	10.5	7.9/9.6	037	037	037	037
		105A00	16.0	12.0/14.7	037	037	038	038
	HIGH	101A00	4.4	3.3/4.0	037	037	037	037
		102A00	6.5	4.9/6.0	037	037	037	037
		103B00	8.7	6.5/8.0	037	037	037	037
		104B00	10.5	7.9/9.6	037	037	037	037
		105A00	16.0	12.0/14.7	037	037	038	038
460-3-60	STD	106A00	6.0	5.5	-	-	-	-
		107A00	8.8	8.1	-	-	-	-
		108A00	11.5	10.6	-	-	-	-
		109A00	14.0	12.9	-	-	-	-
	MED	106A00	6.0	5.5	-	-	-	-
		107A00	8.8	8.1	-	-	-	-
		108A00	11.5	10.6	-	-	-	-
		109A00	14.0	12.9	-	-	-	-
	HIGH	106A00	6.0	5.5	-	-	-	-
		107A00	8.8	8.1	-	-	-	-
		108A00	11.5	10.6	-	-	-	-
		109A00	14.0	12.9	-	-	-	-

LEGEND:

- APP PWR - 208 / 230V / 460V / 575V
- C.O. - Convenience outlet
- FLA - Full load amps
- IFM - Indoor fan motor
- NOM PWR - 240V / 480V / 600V
- P.E. - Power exhaust
- PWRD - Powered convenience outlet
- UNPWRD - Unpowered convenience outlet

ELECTRIC HEAT - ELECTRICAL INFORMATION

(UNITS PRODUCED ON OR AFTER JULY 30, 2012)

Table 11 (cont.) - 50TC**05

1-STAGE COOLING 1-SPEED INDOOR FAN MOTOR WITHOUT FACTORY INSTALLED NON-FUSED DISCONNECT

NOM. V-PH-Hz.	IFM TYPE	ELECTRIC HEATER PART NUMBER CRHEATERXXXXXX	NOM PWR (kW)	APP PWR (kW)	SINGLE POINT KIT PART NUMBER CRSINGLEXXXXXX			
					NO C.O. or UNPWRD C.O.		w/PWRD C.O.	
					NO P.E.	w/P.E. (pwrd fr/unit)	NO P.E.	w/P.E. (pwrd fr/unit)
208/ 230-1-60	STD	101A00	4.4	3.3/4.0	-	-	-	-
		103B00	8.7	6.5/8.0	037	037	037	037
		102A00,102A00	13.0	9.8/11.9	040	040	040	040
		103B00,103B00	17.4	13.1/16.0	040	040	040	040
		104B00,104B00	21.0	15.8/19.3	040	040	040	040
	MED	101A00	4.4	3.3/4.0	-	-	-	-
		103B00	8.7	6.5/8.0	037	037	037	037
		102A00,102A00	13.0	9.8/11.9	040	040	040	040
		103B00,103B00	17.4	13.1/16.0	040	040	040	040
		104B00,104B00	21.0	15.8/19.3	040	040	040	040
208/ 230-3-60	STD	102A00	6.5	4.9/6.0	-	-	-	-
		103B00	8.7	6.5/8.0	-	-	-	-
		105A00	16.0	12.0/14.7	037	037	038	038
		104B00,104B00	21.0	15.8/19.3	038	038	038	038
	MED	102A00	6.5	4.9/6.0	-	-	-	-
		103B00	8.7	6.5/8.0	-	-	-	-
		105A00	16.0	12.0/14.7	037	037	038	038
		104B00,104B00	21.0	15.8/19.3	038	038	038	038
	HIGH	102A00	6.5	4.9/6.0	-	-	-	-
		103B00	8.7	6.5/8.0	-	-	-	-
		105A00	16.0	12.0/14.7	037	037	038	038
		104B00,104B00	21.0	15.8/19.3	038	038	038	038
460-3-60	STD	106A00	6.0	5.5	-	-	-	-
		108A00	11.5	10.6	-	-	-	-
		109A00	14.0	12.9	-	-	-	-
		108A00,108A00	23.0	21.1	037	037	037	037
	MED	106A00	6.0	5.5	-	-	-	-
		108A00	11.5	10.6	-	-	-	-
		109A00	14.0	12.9	-	-	-	-
		108A00,108A00	23.0	21.1	037	037	037	037
	HIGH	106A00	6.0	5.5	-	-	-	-
		108A00	11.5	10.6	-	-	-	-
		109A00	14.0	12.9	-	-	-	-
		108A00,108A00	23.0	21.1	037	037	037	037

LEGEND:

- APP PWR - 208 / 230V / 460V / 575V
- C.O. - Convenience outlet
- FLA - Full load amps
- IFM - Indoor fan motor
- NOM PWR - 240V / 480V / 600V
- P.E. - Power exhaust
- PWRD - Powered convenience outlet
- UNPWRD - Unpowered convenience outlet

ELECTRIC HEAT - ELECTRICAL INFORMATION

(UNITS PRODUCED ON OR AFTER JULY 30, 2012)

Table 11 (cont.) - 50TC**05

1-STAGE COOLING 1-SPEED INDOOR FAN MOTOR WITH FACTORY INSTALLED NON-FUSED DISCONNECT

NOM. V-PH-Hz.	IFM TYPE	ELECTRIC HEATER PART NUMBER CRHEATERXXXXXX	NOM PWR (kW)	APP PWR (kW)	SINGLE POINT KIT PART NUMBER CRSINGLEXXXXXX				
					NO C.O. or UNPWRD C.O.		w/PWRD C.O.		
					NO P.E.	w/P.E. (pwrd fr/unit)	NO P.E.	w/P.E. (pwrd fr/unit)	
208/ 230-1-60	STD	101A00	4.4	3.3/4.0	037	037	037	037	
		103B00	8.7	6.5/8.0	037	037	037	037	
		102A00,102A00	13.0	9.8/11.9	040	040	040	040	
		103B00,103B00	17.4	13.1/16.0	040	040	040	040	
			104B00,104B00	21.0	15.8/19.3	040	040	040	040
	MED	101A00	4.4	3.3/4.0	037	037	037	037	
		103B00	8.7	6.5/8.0	037	037	037	037	
		102A00,102A00	13.0	9.8/11.9	040	040	040	040	
103B00,103B00		17.4	13.1/16.0	040	040	040	040		
		104B00,104B00	21.0	15.8/19.3	040	040	040	040	
208/ 230-3-60	STD	102A00	6.5	4.9/6.0	037	037	037	037	
		103B00	8.7	6.5/8.0	037	037	037	037	
		105A00	16.0	12.0/14.7	037	037	038	038	
		104B00,104B00	21.0	15.8/19.3	038	038	038	038	
	MED	102A00	6.5	4.9/6.0	037	037	037	037	
		103B00	8.7	6.5/8.0	037	037	037	037	
		105A00	16.0	12.0/14.7	037	037	038	038	
		104B00,104B00	21.0	15.8/19.3	038	038	038	038	
	HIGH	102A00	6.5	4.9/6.0	037	037	037	037	
		103B00	8.7	6.5/8.0	037	037	037	037	
		105A00	16.0	12.0/14.7	037	037	038	038	
		104B00,104B00	21.0	15.8/19.3	038	038	038	038	
460-3-60	STD	106A00	6.0	5.5	-	-	-	-	
		108A00	11.5	10.6	-	-	-	-	
		109A00	14.0	12.9	-	-	-	-	
		108A00,108A00	23.0	21.1	037	037	037	037	
	MED	106A00	6.0	5.5	-	-	-	-	
		108A00	11.5	10.6	-	-	-	-	
		109A00	14.0	12.9	-	-	-	-	
		108A00,108A00	23.0	21.1	037	037	037	037	
	HIGH	106A00	6.0	5.5	-	-	-	-	
		108A00	11.5	10.6	-	-	-	-	
		109A00	14.0	12.9	-	-	-	-	
		108A00,108A00	23.0	21.1	037	037	037	037	

LEGEND:

- APP PWR - 208 / 230V / 460V / 575V
- C.O. - Convenience outlet
- FLA - Full load amps
- IFM - Indoor fan motor
- NOM PWR - 240V / 480V / 600V
- P.E. - Power exhaust
- PWRD - Powered convenience outlet
- UNPWRD - Unpowered convenience outlet

ELECTRIC HEAT - ELECTRICAL INFORMATION

(UNITS PRODUCED ON OR AFTER JULY 30, 2012)

Table 11 (cont.) - 50TC**06

1-STAGE COOLING 1-SPEED INDOOR FAN MOTOR WITHOUT FACTORY INSTALLED NON-FUSED DISCONNECT

NOM. V-PH-Hz.	IFM TYPE	ELECTRIC HEATER PART NUMBER CRHEATERXXXXXX	NOM PWR (kW)	APP PWR (kW)	SINGLE POINT KIT PART NUMBER CRSINGLEXXXXXX			
					NO C.O. or UNPWRD C.O.		w/PWRD C.O.	
					NO P.E.	w/P.E. (pwrd fr/unit)	NO P.E.	w/P.E. (pwrd fr/unit)
208/ 230-1-60	STD	102A00	6.5	4.9/6.0	-	-	-	-
		103B00	8.7	6.5/8.0	037	037	037	037
		102A00,102A00	13.0	9.8/11.9	040	040	040	040
		103B00,103B00	17.4	13.1/16.0	040	040	040	040
		104B00,104B00	21.0	15.8/19.3	040	040	040	040
	MED	102A00	6.5	4.9/6.0	-	-	-	037
		103B00	8.7	6.5/8.0	037	037	040	040
		102A00,102A00	13.0	9.8/11.9	040	040	040	040
		103B00,103B00	17.4	13.1/16.0	040	040	040	040
		104B00,104B00	21.0	15.8/19.3	040	040	040	040
208/ 230-3-60	STD	102A00	6.5	4.9/6.0	-	-	-	-
		104B00	10.5	7.9/9.6	-	-	-	-
		105A00	16.0	12.0/14.7	037	037	038	038
		104B00,104B00	21.0	15.8/19.3	038	038	038	038
		104B00,105A00	26.5	19.9/24.3	038	038	038	038
	MED	102A00	6.5	4.9/6.0	-	-	-	-
		104B00	10.5	7.9/9.6	-	-	-	-
		105A00	16.0	12.0/14.7	037	037	038	038
		104B00,104B00	21.0	15.8/19.3	038	038	038	038
		104B00,105A00	26.5	19.9/24.3	038	038	038	038
	HIGH	102A00	6.5	4.9/6.0	-	-	-	-
		104B00	10.5	7.9/9.6	-	-	-	037
		105A00	16.0	12.0/14.7	037	038	038	038
		104B00,104B00	21.0	15.8/19.3	038	038	038	038
		104B00,105A00	26.5	19.9/24.3	038	038	038	038
460-3-60	STD	106A00	6.0	5.5	-	-	-	-
		108A00	11.5	10.6	-	-	-	-
		109A00	14.0	12.9	-	-	-	-
		108A00,108A00	23.0	21.1	037	037	037	037
		108A00,109A00	25.5	23.4	037	037	037	037
	MED	106A00	6.0	5.5	-	-	-	-
		108A00	11.5	10.6	-	-	-	-
		109A00	14.0	12.9	-	-	-	-
		108A00,108A00	23.0	21.1	037	037	037	037
		108A00,109A00	25.5	23.4	037	037	037	037
	HIGH	106A00	6.0	5.5	-	-	-	-
		108A00	11.5	10.6	-	-	-	-
		109A00	14.0	12.9	-	-	-	-
		108A00,108A00	23.0	21.1	037	037	037	037
		108A00,109A00	25.5	23.4	037	037	037	037

LEGEND:

- APP PWR - 208 / 230V / 460V / 575V
- C.O. - Convenience outlet
- FLA - Full load amps
- IFM - Indoor fan motor
- NOM PWR - 240V / 480V / 600V
- P.E. - Power exhaust
- PWRD - Powered convenience outlet
- UNPWRD - Unpowered convenience outlet

ELECTRIC HEAT - ELECTRICAL INFORMATION

(UNITS PRODUCED ON OR AFTER JULY 30, 2012)

Table 11 (cont.) - 50TC**06

1-STAGE COOLING 1-SPEED INDOOR FAN MOTOR WITH FACTORY INSTALLED NON-FUSED DISCONNECT

NOM. V-PH-Hz.	IFM TYPE	ELECTRIC HEATER PART NUMBER CRHEATERXXXXXX	NOM PWR (kW)	APP PWR (kW)	SINGLE POINT KIT PART NUMBER CRSINGLEXXXXXX			
					NO C.O. or UNPWRD C.O.		w/PWRD C.O.	
					NO P.E.	w/PE. (pwrd fr/unit)	NO P.E.	w/PE. (pwrd fr/unit)
208/ 230-1-60	STD	102A00	6.5	4.9/6.0	037	037	037	037
		103B00	8.7	6.5/8.0	037	037	037	037
		102A00,102A00	13.0	9.8/11.9	040	040	040	040
		103B00,103B00	17.4	13.1/16.0	040	040	040	040
		104B00,104B00	21.0	15.8/19.3	040	040	040	040
	MED	102A00	6.5	4.9/6.0	037	037	037	037
		103B00	8.7	6.5/8.0	037	037	040	040
		102A00,102A00	13.0	9.8/11.9	040	040	040	040
		103B00,103B00	17.4	13.1/16.0	040	040	040	040
		104B00,104B00	21.0	15.8/19.3	040	040	040	040
208/ 230-3-60	STD	102A00	6.5	4.9/6.0	037	037	037	037
		104B00	10.5	7.9/9.6	037	037	037	037
		105A00	16.0	12.0/14.7	037	037	038	038
		104B00,104B00	21.0	15.8/19.3	038	038	038	038
		104B00,105A00	26.5	19.9/24.3	038	038	038	038
	MED	102A00	6.5	4.9/6.0	037	037	037	037
		104B00	10.5	7.9/9.6	037	037	037	037
		105A00	16.0	12.0/14.7	037	037	038	038
		104B00,104B00	21.0	15.8/19.3	038	038	038	038
		104B00,105A00	26.5	19.9/24.3	038	038	038	038
	HIGH	102A00	6.5	4.9/6.0	037	037	037	037
		104B00	10.5	7.9/9.6	037	037	037	037
		105A00	16.0	12.0/14.7	037	038	038	038
		104B00,104B00	21.0	15.8/19.3	038	038	038	038
		104B00,105A00	26.5	19.9/24.3	038	038	038	038
460-3-60	STD	106A00	6.0	5.5	-	-	-	-
		108A00	11.5	10.6	-	-	-	-
		109A00	14.0	12.9	-	-	-	-
		108A00,108A00	23.0	21.1	037	037	037	037
		108A00,109A00	25.5	23.4	037	037	037	037
	MED	106A00	6.0	5.5	-	-	-	-
		108A00	11.5	10.6	-	-	-	-
		109A00	14.0	12.9	-	-	-	-
		108A00,108A00	23.0	21.1	037	037	037	037
		108A00,109A00	25.5	23.4	037	037	037	037
	HIGH	106A00	6.0	5.5	-	-	-	-
		108A00	11.5	10.6	-	-	-	-
		109A00	14.0	12.9	-	-	-	-
		108A00,108A00	23.0	21.1	037	037	037	037
		108A00,109A00	25.5	23.4	037	037	037	037

LEGEND:

- APP PWR - 208 / 230V / 460V / 575V
- C.O. - Convenience outlet
- FLA - Full load amps
- IFM - Indoor fan motor
- NOM PWR - 240V / 480V / 600V
- P.E. - Power exhaust
- PWRD - Powered convenience outlet
- UNPWRD - Unpowered convenience outlet

ELECTRIC HEAT - ELECTRICAL INFORMATION (UNITS PRODUCED ON OR AFTER JULY 30, 2012)

Table 11 (cont.) - 50TC**07

1-STAGE COOLING 1-SPEED INDOOR FAN MOTOR WITHOUT FACTORY INSTALLED NON-FUSED DISCONNECT

NOM. V-PH-Hz.	IFM TYPE	ELECTRIC HEATER PART NUMBER CRHEATERXXXXXX	NOM PWR (kW)	APP PWR (kW)	SINGLE POINT KIT PART NUMBER CRSINGLEXXXXXX			
					NO C.O. or UNPWRD C.O.		w/PWRD C.O.	
					NO P.E.	w/P.E. (pwr fr/unit)	NO P.E.	w/P.E. (pwr fr/unit)
208/ 230-3-60	STD	102A00	6.5	4.9/6.0	-	-	-	-
		104B00	10.5	7.9/9.6	-	-	-	-
		105A00	16.0	12.0/14.7	037	037	038	038
		104B00,104B00	21.0	15.8/19.3	038	038	038	038
		104B00,105A00	26.5	19.9/24.3	038	038	038	038
	MED	102A00	6.5	4.9/6.0	-	-	-	-
		104B00	10.5	7.9/9.6	-	-	-	037
		105A00	16.0	12.0/14.7	037	038	038	038
		104B00,104B00	21.0	15.8/19.3	038	038	038	038
		104B00,105A00	26.5	19.9/24.3	038	038	038	038
	HIGH	102A00	6.5	4.9/6.0	-	-	-	-
		104B00	10.5	7.9/9.6	-	-	037	037
		105A00	16.0	12.0/14.7	038	038	038	038
		104B00,104B00	21.0	15.8/19.3	038	038	038	038
		104B00,105A00	26.5	19.9/24.3	038	038	038	038
460-3-60	STD	106A00	6.0	5.5	-	-	-	-
		108A00	11.5	10.6	-	-	-	-
		109A00	14.0	12.9	-	-	-	-
		108A00,108A00	23.0	21.1	037	037	037	037
		108A00,109A00	25.5	23.4	037	037	037	037
	MED	106A00	6.0	5.5	-	-	-	-
		108A00	11.5	10.6	-	-	-	-
		109A00	14.0	12.9	-	-	-	-
		108A00,108A00	23.0	21.1	037	037	037	037
		108A00,109A00	25.5	23.4	037	037	037	037
	HIGH	106A00	6.0	5.5	-	-	-	-
		108A00	11.5	10.6	-	-	-	-
		109A00	14.0	12.9	-	-	-	-
		108A00,108A00	23.0	21.1	037	037	037	037
		108A00,109A00	25.5	23.4	037	037	037	037

LEGEND:

- APP PWR - 208 / 230V / 460V / 575V
- C.O. - Convenience outlet
- FLA - Full load amps
- IFM - Indoor fan motor
- NOM PWR - 240V / 480V / 600V
- P.E. - Power exhaust
- PWRD - Powered convenience outlet
- UNPWRD - Unpowered convenience outlet

ELECTRIC HEAT - ELECTRICAL INFORMATION (UNITS PRODUCED ON OR AFTER JULY 30, 2012)

Table 11 (cont.) - 50TC**07

1-STAGE COOLING 1-SPEED INDOOR FAN MOTOR WITH FACTORY INSTALLED NON-FUSED DISCONNECT

NOM. V-PH-Hz.	IFM TYPE	ELECTRIC HEATER PART NUMBER CRHEATERXXXXXX	NOM PWR (kW)	APP PWR (kW)	SINGLE POINT KIT PART NUMBER CRSINGLEXXXXXX			
					NO C.O. or UNPWRD C.O.		w/PWRD C.O.	
					NO P.E.	w/P.E. (pwrd fr/unit)	NO P.E.	w/P.E. (pwrd fr/unit)
208/ 230-3-60	STD	102A00	6.5	4.9/6.0	037	037	037	037
		104B00	10.5	7.9/9.6	037	037	037	037
		105A00	16.0	12.0/14.7	037	037	038	038
		104B00,104B00	21.0	15.8/19.3	038	038	038	038
		104B00,105A00	26.5	19.9/24.3	038	038	038	038
	MED	102A00	6.5	4.9/6.0	037	037	037	037
		104B00	10.5	7.9/9.6	037	037	037	037
		105A00	16.0	12.0/14.7	037	038	038	038
		104B00,104B00	21.0	15.8/19.3	038	038	038	038
		104B00,105A00	26.5	19.9/24.3	038	038	038	038
	HIGH	102A00	6.5	4.9/6.0	037	037	037	037
		104B00	10.5	7.9/9.6	037	037	037	037
		105A00	16.0	12.0/14.7	038	038	038	038
		104B00,104B00	21.0	15.8/19.3	038	038	038	038
		104B00,105A00	26.5	19.9/24.3	038	038	038	038
460-3-60	STD	106A00	6.0	5.5	-	-	-	-
		108A00	11.5	10.6	-	-	-	-
		109A00	14.0	12.9	-	-	-	-
		108A00,108A00	23.0	21.1	037	037	037	037
		108A00,109A00	25.5	23.4	037	037	037	037
	MED	106A00	6.0	5.5	-	-	-	-
		108A00	11.5	10.6	-	-	-	-
		109A00	14.0	12.9	-	-	-	-
		108A00,108A00	23.0	21.1	037	037	037	037
		108A00,109A00	25.5	23.4	037	037	037	037
	HIGH	106A00	6.0	5.5	-	-	-	-
		108A00	11.5	10.6	-	-	-	-
		109A00	14.0	12.9	-	-	-	-
		108A00,108A00	23.0	21.1	037	037	037	037
		108A00,109A00	25.5	23.4	037	037	037	037

LEGEND:

- APP PWR - 208 / 230V / 460V / 575V
- C.O. - Convenience outlet
- FLA - Full load amps
- IFM - Indoor fan motor
- NOM PWR - 240V / 480V / 600V
- P.E. - Power exhaust
- PWRD - Powered convenience outlet
- UNPWRD - Unpowered convenience outlet

ELECTRIC HEAT - ELECTRICAL INFORMATION (UNITS PRODUCED ON OR AFTER JULY 30, 2012)

Table 11 (cont.) - 50TC**08

1-STAGE COOLING 1-SPEED INDOOR FAN MOTOR WITHOUT FACTORY INSTALLED NON-FUSED DISCONNECT

NOM. V-PH-Hz.	IFM TYPE	ELECTRIC HEATER PART NUMBER CRHEATERXXXXXX	NOM PWR (kW)	APP PWR (kW)	SINGLE POINT KIT PART NUMBER CRSINGLEXXXXXX			
					NO C.O. or UNPWRD C.O.		w/PWRD C.O.	
					NO P.E.	w/P.E. (pwrd fr/unit)	NO P.E.	w/P.E. (pwrd fr/unit)
208/ 230-3-60	STD	117A00	10.4	7.8/9.6	042	042	042	042
		110A00	16.0	12.0/14.7	042	042	043	043
		111A00	24.8	18.6/22.8	043	043	043	043
		112A00	32.0	24.0/29.4	043	043	043	043
		112A00,117A00	42.4	31.8/38.9	045	045	045	045
	MED	117A00	10.4	7.8/9.6	042	042	042	042
		110A00	16.0	12.0/14.7	042	043	043	043
		111A00	24.8	18.6/22.8	043	043	043	043
		112A00	32.0	24.0/29.4	043	043	043	043
		112A00,117A00	42.4	31.8/38.9	045	045	045	045
	HIGH	117A00	10.4	7.8/9.6	042	042	042	043
		110A00	16.0	12.0/14.7	043	043	043	043
111A00		24.8	18.6/22.8	043	043	043	043	
112A00		32.0	24.0/29.4	043	043	043	043	
112A00,117A00		42.4	31.8/38.9	045	045	045	045	
460-3-60	STD	116A00	13.9	12.8	042	042	042	042
		113A00	16.5	15.2	042	042	042	042
		114A00	27.8	25.5	042	042	042	042
		115A00	33.0	30.3	042	042	042	042
		114A00,116A00	41.7	38.3	044	044	044	044
	MED	116A00	13.9	12.8	042	042	042	042
		113A00	16.5	15.2	042	042	042	042
		114A00	27.8	25.5	042	042	042	042
		115A00	33.0	30.3	042	042	042	042
		114A00,116A00	41.7	38.3	044	044	044	044
	HIGH	116A00	13.9	12.8	042	042	042	042
		113A00	16.5	15.2	042	042	042	042
114A00		27.8	25.5	042	042	042	042	
115A00		33.0	30.3	042	042	044	044	
114A00,116A00		41.7	38.3	044	044	044	044	
575-3-60	STD	118A00	17.0	17.0	042	042	042	042
		119A00	34.0	34.0	042	042	042	044
	MED	118A00	17.0	17.0	042	042	042	042
		119A00	34.0	34.0	042	042	042	044
	HIGH	118A00	17.0	17.0	042	042	042	042
		119A00	34.0	34.0	042	044	044	044

LEGEND:

- APP PWR - 208 / 230V / 460V / 575V
- C.O. - Convenience outlet
- FLA - Full load amps
- IFM - Indoor fan motor
- NOM PWR - 240V / 480V / 600V
- P.E. - Power exhaust
- PWRD - Powered convenience outlet
- UNPWRD - Unpowered convenience outlet

ELECTRIC HEAT - ELECTRICAL INFORMATION (UNITS PRODUCED ON OR AFTER JULY 30, 2012)

Table 11 (cont.) - 50TC**08

1-STAGE COOLING 1-SPEED INDOOR FAN MOTOR WITH FACTORY INSTALLED NON-FUSED DISCONNECT

NOM. V-PH-Hz.	IFM TYPE	ELECTRIC HEATER PART NUMBER CRHEATERXXXXXX	NOM PWR (kW)	APP PWR (kW)	SINGLE POINT KIT PART NUMBER CRSINGLEXXXXXX			
					NO C.O. or UNPWRD C.O.		w/PWRD C.O.	
					NO P.E.	w/P.E. (pwrd fr/unit)	NO P.E.	w/P.E. (pwrd fr/unit)
208/ 230-3-60	STD	117A00	10.4	7.8/9.6	042	042	042	042
		110A00	16.0	12.0/14.7	042	042	043	043
		111A00	24.8	18.6/22.8	043	043	043	043
		112A00	32.0	24.0/29.4	043	043	043	043
		112A00,117A00	42.4	31.8/38.9	045	045	045	045
	MED	117A00	10.4	7.8/9.6	042	042	042	042
		110A00	16.0	12.0/14.7	042	043	043	043
		111A00	24.8	18.6/22.8	043	043	043	043
		112A00	32.0	24.0/29.4	043	043	043	043
		112A00,117A00	42.4	31.8/38.9	045	045	045	045
	HIGH	117A00	10.4	7.8/9.6	042	042	042	043
		110A00	16.0	12.0/14.7	043	043	043	043
111A00		24.8	18.6/22.8	043	043	043	043	
112A00		32.0	24.0/29.4	043	043	043	043	
112A00,117A00		42.4	31.8/38.9	045	045	045	045	
460-3-60	STD	116A00	13.9	12.8	042	042	042	042
		113A00	16.5	15.2	042	042	042	042
		114A00	27.8	25.5	042	042	042	042
		115A00	33.0	30.3	042	042	042	042
		114A00,116A00	41.7	38.3	044	044	044	044
	MED	116A00	13.9	12.8	042	042	042	042
		113A00	16.5	15.2	042	042	042	042
		114A00	27.8	25.5	042	042	042	042
		115A00	33.0	30.3	042	042	042	042
		114A00,116A00	41.7	38.3	044	044	044	044
	HIGH	116A00	13.9	12.8	042	042	042	042
		113A00	16.5	15.2	042	042	042	042
114A00		27.8	25.5	042	042	042	042	
115A00		33.0	30.3	042	042	044	044	
114A00,116A00		41.7	38.3	044	044	044	044	
575-3-60	STD	118A00	17.0	17.0	042	042	042	042
		119A00	34.0	34.0	042	042	042	044
	MED	118A00	17.0	17.0	042	042	042	042
		119A00	34.0	34.0	042	042	042	044
	HIGH	118A00	17.0	17.0	042	042	042	042
		119A00	34.0	34.0	042	044	044	044

LEGEND:

- APP PWR - 208 / 230V / 460V / 575V
- C.O. - Convenience outlet
- FLA - Full load amps
- IFM - Indoor fan motor
- NOM PWR - 240V / 480V / 600V
- P.E. - Power exhaust
- PWRD - Powered convenience outlet
- UNPWRD - Unpowered convenience outlet

ELECTRIC HEAT - ELECTRICAL INFORMATION (UNITS PRODUCED ON OR AFTER JULY 30, 2012)

Table 11 (cont.) - 50TC**08

2-STAGE COOLING 1-SPEED INDOOR FAN MOTOR WITHOUT FACTORY INSTALLED NON-FUSED DISCONNECT

NOM. V-PH-Hz.	IFM TYPE	ELECTRIC HEATER PART NUMBER CRHEATERXXXXXX	NOM PWR (kW)	APP PWR (kW)	SINGLE POINT KIT PART NUMBER CRSINGLEXXXXXX			
					NO C.O. or UNPWRD C.O.		w/PWRD C.O.	
					NO P.E.	w/P.E. (pwrd fr/unit)	NO P.E.	w/P.E. (pwrd fr/unit)
208/ 230-3-60	STD	117A00	10.4	7.8/9.6	042	042	042	042
		110A00	16.0	12.0/14.7	042	042	043	043
		111A00	24.8	18.6/22.8	043	043	043	043
		112A00	32.0	24.0/29.4	043	043	043	043
		112A00,117A00	42.4	31.8/38.9	045	045	045	045
	MED	117A00	10.4	7.8/9.6	042	042	042	042
		110A00	16.0	12.0/14.7	042	043	043	043
		111A00	24.8	18.6/22.8	043	043	043	043
		112A00	32.0	24.0/29.4	043	043	043	043
		112A00,117A00	42.4	31.8/38.9	045	045	045	045
	HIGH	117A00	10.4	7.8/9.6	042	042	042	042
		110A00	16.0	12.0/14.7	043	043	043	043
111A00		24.8	18.6/22.8	043	043	043	043	
112A00		32.0	24.0/29.4	043	043	043	043	
112A00,117A00		42.4	31.8/38.9	045	045	045	045	
460-3-60	STD	116A00	13.9	12.8	042	042	042	042
		113A00	16.5	15.2	042	042	042	042
		114A00	27.8	25.5	042	042	042	042
		115A00	33.0	30.3	042	042	042	042
		114A00,116A00	41.7	38.3	044	044	044	044
	MED	116A00	13.9	12.8	042	042	042	042
		113A00	16.5	15.2	042	042	042	042
		114A00	27.8	25.5	042	042	042	042
		115A00	33.0	30.3	042	042	042	042
		114A00,116A00	41.7	38.3	044	044	044	044
	HIGH	116A00	13.9	12.8	042	042	042	042
		113A00	16.5	15.2	042	042	042	042
114A00		27.8	25.5	042	042	042	042	
115A00		33.0	30.3	042	042	044	044	
114A00,116A00		41.7	38.3	044	044	044	044	
575-3-60	STD	118A00	17.0	17.0	042	042	042	042
		119A00	34.0	34.0	042	042	042	044
	MED	118A00	17.0	17.0	042	042	042	042
		119A00	34.0	34.0	042	042	042	044
	HIGH	118A00	17.0	17.0	042	042	042	042
		119A00	34.0	34.0	042	044	044	044

LEGEND:

- APP PWR - 208 / 230V / 460V / 575V
- C.O. - Convenience outlet
- FLA - Full load amps
- IFM - Indoor fan motor
- NOM PWR - 240V / 480V / 600V
- P.E. - Power exhaust
- PWRD - Powered convenience outlet
- UNPWRD - Unpowered convenience outlet

ELECTRIC HEAT - ELECTRICAL INFORMATION (UNITS PRODUCED ON OR AFTER JULY 30, 2012)

Table 11 (cont.) - 50TC**08

2-STAGE COOLING 1-SPEED INDOOR FAN MOTOR WITH FACTORY INSTALLED NON-FUSED DISCONNECT

NOM. V-PH-Hz.	IFM TYPE	ELECTRIC HEATER PART NUMBER CRHEATERXXXXXX	NOM PWR (kW)	APP PWR (kW)	SINGLE POINT KIT PART NUMBER CRSINGLEXXXXXX			
					NO C.O. or UNPWRD C.O.		w/PWRD C.O.	
					NO P.E.	w/P.E. (pwrd fr/unit)	NO P.E.	w/P.E. (pwrd fr/unit)
208/ 230-3-60	STD	117A00	10.4	7.8/9.6	042	042	042	042
		110A00	16.0	12.0/14.7	042	042	043	043
		111A00	24.8	18.6/22.8	043	043	043	043
		112A00	32.0	24.0/29.4	043	043	043	043
		112A00,117A00	42.4	31.8/38.9	045	045	045	045
	MED	117A00	10.4	7.8/9.6	042	042	042	042
		110A00	16.0	12.0/14.7	042	043	043	043
		111A00	24.8	18.6/22.8	043	043	043	043
		112A00	32.0	24.0/29.4	043	043	043	043
		112A00,117A00	42.4	31.8/38.9	045	045	045	045
	HIGH	117A00	10.4	7.8/9.6	042	042	042	042
		110A00	16.0	12.0/14.7	043	043	043	043
111A00		24.8	18.6/22.8	043	043	043	043	
112A00		32.0	24.0/29.4	043	043	043	043	
112A00,117A00		42.4	31.8/38.9	045	045	045	045	
460-3-60	STD	116A00	13.9	12.8	042	042	042	042
		113A00	16.5	15.2	042	042	042	042
		114A00	27.8	25.5	042	042	042	042
		115A00	33.0	30.3	042	042	042	042
		114A00,116A00	41.7	38.3	044	044	044	044
	MED	116A00	13.9	12.8	042	042	042	042
		113A00	16.5	15.2	042	042	042	042
		114A00	27.8	25.5	042	042	042	042
		115A00	33.0	30.3	042	042	042	042
		114A00,116A00	41.7	38.3	044	044	044	044
	HIGH	116A00	13.9	12.8	042	042	042	042
		113A00	16.5	15.2	042	042	042	042
114A00		27.8	25.5	042	042	042	042	
115A00		33.0	30.3	042	042	044	044	
114A00,116A00		41.7	38.3	044	044	044	044	
575-3-60	STD	118A00	17.0	17.0	042	042	042	042
		119A00	34.0	34.0	042	042	042	044
	MED	118A00	17.0	17.0	042	042	042	042
		119A00	34.0	34.0	042	042	042	044
	HIGH	118A00	17.0	17.0	042	042	042	042
		119A00	34.0	34.0	042	044	044	044

LEGEND:

- APP PWR - 208 / 230V / 460V / 575V
- C.O. - Convenience outlet
- FLA - Full load amps
- IFM - Indoor fan motor
- NOM PWR - 240V / 480V / 600V
- P.E. - Power exhaust
- PWRD - Powered convenience outlet
- UNPWRD - Unpowered convenience outlet

ELECTRIC HEAT - ELECTRICAL INFORMATION (UNITS PRODUCED ON OR AFTER JULY 30, 2012)

Table 11 (cont.) - 50TC**08

2-STAGE COOLING 2-SPEED INDOOR FAN MOTOR WITHOUT FACTORY INSTALLED NON-FUSED DISCONNECT

NOM. V-PH-Hz.	IFM TYPE	ELECTRIC HEATER PART NUMBER CRHEATERXXXXXX	NOM PWR (kW)	APP PWR (kW)	SINGLE POINT KIT PART NUMBER CRSINGLEXXXXXX			
					NO C.O. or UNPWRD C.O.		w/PWRD C.O.	
					NO P.E.	w/P.E. (pwrd fr/unit)	NO P.E.	w/P.E. (pwrd fr/unit)
208/ 230-3-60	STD	117A00	10.4	7.8/9.6	042	042	042	042
		110A00	16.0	12.0/14.7	042	042	043	043
		111A00	24.8	18.6/22.8	043	043	043	043
		112A00	32.0	24.0/29.4	043	043	043	043
		112A00,117A00	42.4	31.8/38.9	045	045	045	045
	MED	117A00	10.4	7.8/9.6	042	042	042	042
		110A00	16.0	12.0/14.7	042	043	043	043
		111A00	24.8	18.6/22.8	043	043	043	043
		112A00	32.0	24.0/29.4	043	043	043	043
		112A00,117A00	42.4	31.8/38.9	045	045	045	045
	HIGH	117A00	10.4	7.8/9.6	042	042	042	042
		110A00	16.0	12.0/14.7	043	043	043	043
111A00		24.8	18.6/22.8	043	043	043	043	
112A00		32.0	24.0/29.4	043	043	043	043	
112A00,117A00		42.4	31.8/38.9	045	045	045	045	
460-3-60	STD	116A00	13.9	12.8	042	042	042	042
		113A00	16.5	15.2	042	042	042	042
		114A00	27.8	25.5	042	042	042	042
		115A00	33.0	30.3	042	042	042	042
		114A00,116A00	41.7	38.3	044	044	044	044
	MED	116A00	13.9	12.8	042	042	042	042
		113A00	16.5	15.2	042	042	042	042
		114A00	27.8	25.5	042	042	042	042
		115A00	33.0	30.3	042	042	042	042
		114A00,116A00	41.7	38.3	044	044	044	044
	HIGH	116A00	13.9	12.8	042	042	042	042
		113A00	16.5	15.2	042	042	042	042
114A00		27.8	25.5	042	042	042	042	
115A00		33.0	30.3	042	042	044	044	
114A00,116A00		41.7	38.3	044	044	044	044	
575-3-60	STD	118A00	17.0	17.0	042	042	042	042
		119A00	34.0	34.0	042	042	042	044
	MED	118A00	17.0	17.0	042	042	042	042
		119A00	34.0	34.0	042	044	042	044
	HIGH	118A00	17.0	17.0	042	042	042	042
		119A00	34.0	34.0	042	044	044	044

LEGEND:

- APP PWR - 208 / 230V / 460V / 575V
- C.O. - Convenience outlet
- FLA - Full load amps
- IFM - Indoor fan motor
- NOM PWR - 240V / 480V / 600V
- P.E. - Power exhaust
- PWRD - Powered convenience outlet
- UNPWRD - Unpowered convenience outlet

ELECTRIC HEAT - ELECTRICAL INFORMATION (UNITS PRODUCED ON OR AFTER JULY 30, 2012)

Table 11 (cont.) - 50TC**09

1-STAGE COOLING 1-SPEED INDOOR FAN MOTOR WITHOUT FACTORY INSTALLED NON-FUSED DISCONNECT

NOM. V-PH-Hz.	IFM TYPE	ELECTRIC HEATER PART NUMBER CRHEATERXXXXXX	NOM PWR (kW)	APP PWR (kW)	SINGLE POINT KIT PART NUMBER CRSINGLEXXXXXX			
					NO C.O. or UNPWRD C.O.		w/PWRD C.O.	
					NO P.E.	w/P.E. (pwrd fr/unit)	NO P.E.	w/P.E. (pwrd fr/unit)
208/ 203-3-60	STD	117A00	10.4	7.8/9.6	047	047	047	049
		110A00	16.0	12.0/14.7	047	047	049	049
		111A00	24.8	18.6/22.8	049	049	049	049
		112A00	32.0	24.0/29.4	049	049	049	049
		112A00,117A00	42.4	31.8/38.9	051	051	051	051
	MED	117A00	10.4	7.8/9.6	047	047	047	049
		110A00	16.0	12.0/14.7	047	049	049	049
		111A00	24.8	18.6/22.8	049	049	049	049
		112A00	32.0	24.0/29.4	049	049	049	049
		112A00,117A00	42.4	31.8/38.9	051	051	051	051
	HIGH	117A00	10.4	7.8/9.6	047	049	049	049
		110A00	16.0	12.0/14.7	049	049	049	049
		111A00	24.8	18.6/22.8	049	049	049	049
		112A00	32.0	24.0/29.4	049	049	049	049
		112A00,117A00	42.4	31.8/38.9	051	051	051	051
460-3-60	STD	116A00	13.9	12.8	047	047	047	047
		113A00	16.5	15.2	047	047	047	047
		114A00	27.8	25.5	047	047	047	047
		115A00	33.0	30.3	047	047	047	047
		114A00,116A00	41.7	38.3	050	050	050	050
	MED	116A00	13.9	12.8	047	047	047	047
		113A00	16.5	15.2	047	047	047	047
		114A00	27.8	25.5	047	047	047	047
		115A00	33.0	30.3	047	047	047	047
		114A00,116A00	41.7	38.3	050	050	050	050
	HIGH	116A00	13.9	12.8	047	047	047	047
		113A00	16.5	15.2	047	047	047	047
		114A00	27.8	25.5	047	047	047	047
		115A00	33.0	30.3	047	047	047	050
		114A00,116A00	41.7	38.3	050	050	050	050
575-3-60	STD	118A00	17.0	17.0	047	047	047	047
		119A00	34.0	34.0	047	047	047	050
	MED	118A00	17.0	17.0	047	047	047	047
		119A00	34.0	34.0	047	047	047	050
	HIGH	118A00	17.0	17.0	047	047	047	047
		119A00	34.0	34.0	047	047	047	050

LEGEND:

- APP PWR - 208 / 230V / 460V / 575V
- C.O. - Convenience outlet
- FLA - Full load amps
- IFM - Indoor fan motor
- NOM PWR - 240V / 480V / 600V
- P.E. - Power exhaust
- PWRD - Powered convenience outlet
- UNPWRD - Unpowered convenience outlet

ELECTRIC HEAT - ELECTRICAL INFORMATION (UNITS PRODUCED ON OR AFTER JULY 30, 2012)

Table 11 (cont.) - 50TC**09

1-STAGE COOLING 1-SPEED INDOOR FAN MOTOR WITH FACTORY INSTALLED NON-FUSED DISCONNECT

NOM. V-PH-Hz.	IFM TYPE	ELECTRIC HEATER PART NUMBER CRHEATERXXXXXX	NOM PWR (kW)	APP PWR (kW)	SINGLE POINT KIT PART NUMBER CRSINGLEXXXXXX			
					NO C.O. or UNPWRD C.O.		w/PWRD C.O.	
					NO P.E.	w/P.E. (pwrd fr/unit)	NO P.E.	w/P.E. (pwrd fr/unit)
208/ 203-3-60	STD	117A00	10.4	7.8/9.6	047	047	047	049
		110A00	16.0	12.0/14.7	047	047	049	049
		111A00	24.8	18.6/22.8	049	049	049	049
		112A00	32.0	24.0/29.4	049	049	049	049
		112A00,117A00	42.4	31.8/38.9	051	051	051	051
	MED	117A00	10.4	7.8/9.6	047	047	047	049
		110A00	16.0	12.0/14.7	047	049	049	049
		111A00	24.8	18.6/22.8	049	049	049	049
		112A00	32.0	24.0/29.4	049	049	049	049
		112A00,117A00	42.4	31.8/38.9	051	051	051	051
	HIGH	117A00	10.4	7.8/9.6	047	049	049	049
		110A00	16.0	12.0/14.7	049	049	049	049
		111A00	24.8	18.6/22.8	049	049	049	049
		112A00	32.0	24.0/29.4	049	049	049	049
		112A00,117A00	42.4	31.8/38.9	051	051	051	051
460-3-60	STD	116A00	13.9	12.8	047	047	047	047
		113A00	16.5	15.2	047	047	047	047
		114A00	27.8	25.5	047	047	047	047
		115A00	33.0	30.3	047	047	047	047
		114A00,116A00	41.7	38.3	050	050	050	050
	MED	116A00	13.9	12.8	047	047	047	047
		113A00	16.5	15.2	047	047	047	047
		114A00	27.8	25.5	047	047	047	047
		115A00	33.0	30.3	047	047	047	047
		114A00,116A00	41.7	38.3	050	050	050	050
	HIGH	116A00	13.9	12.8	047	047	047	047
		113A00	16.5	15.2	047	047	047	047
		114A00	27.8	25.5	047	047	047	047
		115A00	33.0	30.3	047	047	047	050
		114A00,116A00	41.7	38.3	050	050	050	050
575-3-60	STD	118A00	17.0	17.0	047	047	047	047
		119A00	34.0	34.0	047	047	047	050
	MED	118A00	17.0	17.0	047	047	047	047
		119A00	34.0	34.0	047	047	047	050
	HIGH	118A00	17.0	17.0	047	047	047	047
		119A00	34.0	34.0	047	047	047	050

LEGEND:

- APP PWR - 208 / 230V / 460V / 575V
- C.O. - Convenience outlet
- FLA - Full load amps
- IFM - Indoor fan motor
- NOM PWR - 240V / 480V / 600V
- P.E. - Power exhaust
- PWRD - Powered convenience outlet
- UNPWRD - Unpowered convenience outlet

ELECTRIC HEAT - ELECTRICAL INFORMATION (UNITS PRODUCED ON OR AFTER JULY 30, 2012)

Table 11 (cont.) - 50TC**09

2-STAGE COOLING 1-SPEED INDOOR FAN MOTOR WITHOUT FACTORY INSTALLED NON-FUSED DISCONNECT

NOM. V-PH-Hz.	IFM TYPE	ELECTRIC HEATER PART NUMBER CRHEATERXXXXXX	NOM PWR (kW)	APP PWR (kW)	SINGLE POINT KIT PART NUMBER CRSINGLEXXXXXX			
					NO C.O. or UNPWRD C.O.		w/PWRD C.O.	
					NO P.E.	w/P.E. (pwrd fr/unit)	NO P.E.	w/P.E. (pwrd fr/unit)
208/ 203-3-60	STD	117A00	10.4	7.8/9.6	047	047	047	047
		110A00	16.0	12.0/14.7	047	047	049	049
		111A00	24.8	18.6/22.8	049	049	049	049
		112A00	32.0	24.0/29.4	049	049	049	049
		112A00,117A00	42.4	31.8/38.9	051	051	051	051
	MED	117A00	10.4	7.8/9.6	047	047	047	047
		110A00	16.0	12.0/14.7	047	049	049	049
		111A00	24.8	18.6/22.8	049	049	049	049
		112A00	32.0	24.0/29.4	049	049	049	049
		112A00,117A00	42.4	31.8/38.9	051	051	051	051
	HIGH	117A00	10.4	7.8/9.6	047	047	047	047
		110A00	16.0	12.0/14.7	049	049	049	049
		111A00	24.8	18.6/22.8	049	049	049	049
		112A00	32.0	24.0/29.4	049	049	049	049
		112A00,117A00	42.4	31.8/38.9	051	051	051	051
460-3-60	STD	116A00	13.9	12.8	047	047	047	047
		113A00	16.5	15.2	047	047	047	047
		114A00	27.8	25.5	047	047	047	047
		115A00	33.0	30.3	047	047	047	047
		114A00,116A00	41.7	38.3	050	050	050	050
	MED	116A00	13.9	12.8	047	047	047	047
		113A00	16.5	15.2	047	047	047	047
		114A00	27.8	25.5	047	047	047	047
		115A00	33.0	30.3	047	047	047	047
		114A00,116A00	41.7	38.3	050	050	050	050
	HIGH	116A00	13.9	12.8	047	047	047	047
		113A00	16.5	15.2	047	047	047	047
		114A00	27.8	25.5	047	047	047	047
		115A00	33.0	30.3	047	047	047	050
		114A00,116A00	41.7	38.3	050	050	050	050
575-3-60	STD	118A00	17.0	17.0	047	047	047	047
		119A00	34.0	34.0	047	047	047	050
	MED	118A00	17.0	17.0	047	047	047	047
		119A00	34.0	34.0	047	047	047	050
	HIGH	118A00	17.0	17.0	047	047	047	047
		119A00	34.0	34.0	047	047	047	050

LEGEND:

- APP PWR - 208 / 230V / 460V / 575V
- C.O. - Convenience outlet
- FLA - Full load amps
- IFM - Indoor fan motor
- NOM PWR - 240V / 480V / 600V
- P.E. - Power exhaust
- PWRD - Powered convenience outlet
- UNPWRD - Unpowered convenience outlet

ELECTRIC HEAT - ELECTRICAL INFORMATION (UNITS PRODUCED ON OR AFTER JULY 30, 2012)

Table 11 (cont.) - 50TC**09

2-STAGE COOLING 1-SPEED INDOOR FAN MOTOR WITH FACTORY INSTALLED NON-FUSED DISCONNECT

NOM. V-PH-Hz.	IFM TYPE	ELECTRIC HEATER PART NUMBER CRHEATERXXXXXX	NOM PWR (kW)	APP PWR (kW)	SINGLE POINT KIT PART NUMBER CRSINGLEXXXXXX			
					NO C.O. or UNPWRD C.O.		w/PWRD C.O.	
					NO P.E.	w/P.E. (pwrd fr/unit)	NO P.E.	w/P.E. (pwrd fr/unit)
208/ 203-3-60	STD	117A00	10.4	7.8/9.6	047	047	047	047
		110A00	16.0	12.0/14.7	047	047	049	049
		111A00	24.8	18.6/22.8	049	049	049	049
		112A00	32.0	24.0/29.4	049	049	049	049
		112A00,117A00	42.4	31.8/38.9	051	051	051	051
	MED	117A00	10.4	7.8/9.6	047	047	047	047
		110A00	16.0	12.0/14.7	047	049	049	049
		111A00	24.8	18.6/22.8	049	049	049	049
		112A00	32.0	24.0/29.4	049	049	049	049
		112A00,117A00	42.4	31.8/38.9	051	051	051	051
	HIGH	117A00	10.4	7.8/9.6	047	047	047	047
		110A00	16.0	12.0/14.7	049	049	049	049
		111A00	24.8	18.6/22.8	049	049	049	049
		112A00	32.0	24.0/29.4	049	049	049	049
		112A00,117A00	42.4	31.8/38.9	051	051	051	051
460-3-60	STD	116A00	13.9	12.8	047	047	047	047
		113A00	16.5	15.2	047	047	047	047
		114A00	27.8	25.5	047	047	047	047
		115A00	33.0	30.3	047	047	047	047
		114A00,116A00	41.7	38.3	050	050	050	050
	MED	116A00	13.9	12.8	047	047	047	047
		113A00	16.5	15.2	047	047	047	047
		114A00	27.8	25.5	047	047	047	047
		115A00	33.0	30.3	047	047	047	047
		114A00,116A00	41.7	38.3	050	050	050	050
	HIGH	116A00	13.9	12.8	047	047	047	047
		113A00	16.5	15.2	047	047	047	047
		114A00	27.8	25.5	047	047	047	047
		115A00	33.0	30.3	047	047	047	050
		114A00,116A00	41.7	38.3	050	050	050	050
575-3-60	STD	118A00	17.0	17.0	047	047	047	047
		119A00	34.0	34.0	047	047	047	050
	MED	118A00	17.0	17.0	047	047	047	047
		119A00	34.0	34.0	047	047	047	050
	HIGH	118A00	17.0	17.0	047	047	047	047
		119A00	34.0	34.0	047	047	047	050

LEGEND:

- APP PWR - 208 / 230V / 460V / 575V
- C.O. - Convenience outlet
- FLA - Full load amps
- IFM - Indoor fan motor
- NOM PWR - 240V / 480V / 600V
- P.E. - Power exhaust
- PWRD - Powered convenience outlet
- UNPWRD - Unpowered convenience outlet

ELECTRIC HEAT - ELECTRICAL INFORMATION (UNITS PRODUCED ON OR AFTER JULY 30, 2012)

Table 11 (cont.) - 50TC**09

2-STAGE COOLING 2-SPEED INDOOR FAN MOTOR WITHOUT FACTORY INSTALLED NON-FUSED DISCONNECT

NOM. V-PH-Hz.	IFM TYPE	ELECTRIC HEATER PART NUMBER CRHEATERXXXXXX	NOM PWR (kW)	APP PWR (kW)	SINGLE POINT KIT PART NUMBER CRSINGLEXXXXXX			
					NO C.O. or UNPWRD C.O.		w/PWRD C.O.	
					NO P.E.	w/P.E. (pwrd fr/unit)	NO P.E.	w/P.E. (pwrd fr/unit)
208/ 203-3-60	STD	117A00	10.4	7.8/9.6	047	047	047	047
		110A00	16.0	12.0/14.7	047	047	049	049
		111A00	24.8	18.6/22.8	049	049	049	049
		112A00	32.0	24.0/29.4	049	049	049	049
		112A00,117A00	42.4	31.8/38.9	051	051	051	051
	MED	117A00	10.4	7.8/9.6	047	047	047	047
		110A00	16.0	12.0/14.7	047	049	049	049
		111A00	24.8	18.6/22.8	049	049	049	049
		112A00	32.0	24.0/29.4	049	049	049	049
		112A00,117A00	42.4	31.8/38.9	051	051	051	051
	HIGH	117A00	10.4	7.8/9.6	047	047	047	047
		110A00	16.0	12.0/14.7	049	049	049	049
		111A00	24.8	18.6/22.8	049	049	049	049
		112A00	32.0	24.0/29.4	049	049	049	049
		112A00,117A00	42.4	31.8/38.9	051	051	051	051
460-3-60	STD	116A00	13.9	12.8	047	047	047	047
		113A00	16.5	15.2	047	047	047	047
		114A00	27.8	25.5	047	047	047	047
		115A00	33.0	30.3	047	047	047	047
		114A00,116A00	41.7	38.3	050	050	050	050
	MED	116A00	13.9	12.8	047	047	047	047
		113A00	16.5	15.2	047	047	047	047
		114A00	27.8	25.5	047	047	047	047
		115A00	33.0	30.3	047	047	047	047
		114A00,116A00	41.7	38.3	050	050	050	050
	HIGH	116A00	13.9	12.8	047	047	047	047
		113A00	16.5	15.2	047	047	047	047
		114A00	27.8	25.5	047	047	047	047
		115A00	33.0	30.3	047	047	047	050
		114A00,116A00	41.7	38.3	050	050	050	050
575-3-60	STD	118A00	17.0	17.0	047	047	047	047
		119A00	34.0	34.0	047	047	047	050
	MED	118A00	17.0	17.0	047	047	047	047
		119A00	34.0	34.0	047	050	047	050
	HIGH	118A00	17.0	17.0	047	047	047	047
		119A00	34.0	34.0	047	050	047	050

LEGEND:

- APP PWR - 208 / 230V / 460V / 575V
- C.O. - Convenience outlet
- FLA - Full load amps
- IFM - Indoor fan motor
- NOM PWR - 240V / 480V / 600V
- P.E. - Power exhaust
- PWRD - Powered convenience outlet
- UNPWRD - Unpowered convenience outlet

ELECTRIC HEAT - ELECTRICAL INFORMATION (UNITS PRODUCED ON OR AFTER JULY 30, 2012)

Table 11 (cont.) - 50TC**12

1-STAGE COOLING 1-SPEED INDOOR FAN MOTOR WITHOUT FACTORY INSTALLED NON-FUSED DISCONNECT

NOM. V-PH-Hz.	IFM TYPE	ELECTRIC HEATER PART NUMBER CRHEATERXXXXXX	NOM PWR (kW)	APP PWR (kW)	SINGLE POINT KIT PART NUMBER CRSINGLEXXXXXX			
					NO C.O. or UNPWRD C.O.		w/PWRD C.O.	
					NO P.E.	w/P.E. (pwr fr/unit)	NO P.E.	w/P.E. (pwr fr/unit)
208/ 230-3-60	STD	117A00	10.4	7.8/9.6	047	047	047	049
		110A00	16.0	12.0/14.7	047	049	049	049
		112A00	32.0	24.0/29.4	049	049	049	049
		112A00,117A00	42.4	31.8/38.9	051	051	051	051
		112A00,110A00	50.0	37.6/45.9	051	051	051	051
	MED	117A00	10.4	7.8/9.6	047	049	049	049
		110A00	16.0	12.0/14.7	049	049	049	049
		112A00	32.0	24.0/29.4	049	049	049	049
		112A00,117A00	42.4	31.8/38.9	051	051	051	051
		112A00,110A00	50.0	37.6/45.9	051	051	051	051
	HIGH	117A00	10.4	7.8/9.6	049	049	049	049
		110A00	16.0	12.0/14.7	049	049	049	049
		112A00	32.0	24.0/29.4	049	049	049	049
		112A00,117A00	42.4	31.8/38.9	051	051	051	051
		112A00,110A00	50.0	37.6/45.9	051	051	051	051
460-3-60	STD	116A00	13.9	12.8	047	047	047	047
		113A00	16.5	15.2	047	047	047	047
		115A00	33.0	30.3	047	047	047	047
		114A00,116A00	41.7	38.3	050	050	050	050
		115A00,113A00	50.0	45.9	050	050	050	050
	MED	116A00	13.9	12.8	047	047	047	047
		113A00	16.5	15.2	047	047	047	047
		115A00	33.0	30.3	047	047	047	050
		114A00,116A00	41.7	38.3	050	050	050	050
		115A00,113A00	50.0	45.9	050	050	050	050
	HIGH	116A00	13.9	12.8	047	047	047	047
		113A00	16.5	15.2	047	047	047	047
		115A00	33.0	30.3	047	047	050	050
		114A00,116A00	41.7	38.3	050	050	050	050
		115A00,113A00	50.0	45.9	050	050	050	050
575-3-60	STD	118A00	17.0	17.0	047	047	047	047
		119A00	34.0	34.0	047	047	047	050
		118A00,119A00	51.0	51.0	050	050	050	050
	MED	118A00	17.0	17.0	047	047	047	047
		119A00	34.0	34.0	047	047	047	050
		118A00,119A00	51.0	51.0	050	050	050	050
	HIGH	118A00	17.0	17.0	047	047	047	047
		119A00	34.0	34.0	047	050	050	050
		118A00,119A00	51.0	51.0	050	050	050	050

LEGEND:

- APP PWR - 208 / 230V / 460V / 575V
- C.O. - Convenience outlet
- FLA - Full load amps
- IFM - Indoor fan motor
- NOM PWR - 240V / 480V / 600V
- P.E. - Power exhaust
- PWRD - Powered convenience outlet
- UNPWRD - Unpowered convenience outlet

ELECTRIC HEAT - ELECTRICAL INFORMATION (UNITS PRODUCED ON OR AFTER JULY 30, 2012)

Table 11 (cont.) - 50TC**12

1-STAGE COOLING 1-SPEED INDOOR FAN MOTOR WITH FACTORY INSTALLED NON-FUSED DISCONNECT

NOM. V-PH-Hz.	IFM TYPE	ELECTRIC HEATER PART NUMBER CRHEATERXXXXXX	NOM PWR (kW)	APP PWR (kW)	SINGLE POINT KIT PART NUMBER CRSINGLEXXXXXX			
					NO C.O. or UNPWRD C.O.		w/PWRD C.O.	
					NO P.E.	w/P.E. (pwr fr/unit)	NO P.E.	w/P.E. (pwr fr/unit)
208/ 230-3-60	STD	117A00	10.4	7.8/9.6	047	047	047	049
		110A00	16.0	12.0/14.7	047	049	049	049
		112A00	32.0	24.0/29.4	049	049	049	049
		112A00,117A00	42.4	31.8/38.9	051	051	051	051
		112A00,110A00	50.0	37.6/45.9	051	051	051	051
	MED	117A00	10.4	7.8/9.6	047	049	049	049
		110A00	16.0	12.0/14.7	049	049	049	049
		112A00	32.0	24.0/29.4	049	049	049	049
		112A00,117A00	42.4	31.8/38.9	051	051	051	051
		112A00,110A00	50.0	37.6/45.9	051	051	051	051
	HIGH	117A00	10.4	7.8/9.6	049	049	049	049
		110A00	16.0	12.0/14.7	049	049	049	049
		112A00	32.0	24.0/29.4	049	049	049	049
		112A00,117A00	42.4	31.8/38.9	051	051	051	051
		112A00,110A00	50.0	37.6/45.9	051	051	051	051
460-3-60	STD	116A00	13.9	12.8	047	047	047	047
		113A00	16.5	15.2	047	047	047	047
		115A00	33.0	30.3	047	047	047	047
		114A00,116A00	41.7	38.3	050	050	050	050
		115A00,113A00	50.0	45.9	050	050	050	050
	MED	116A00	13.9	12.8	047	047	047	047
		113A00	16.5	15.2	047	047	047	047
		115A00	33.0	30.3	047	047	047	050
		114A00,116A00	41.7	38.3	050	050	050	050
		115A00,113A00	50.0	45.9	050	050	050	050
	HIGH	116A00	13.9	12.8	047	047	047	047
		113A00	16.5	15.2	047	047	047	047
		115A00	33.0	30.3	047	047	050	050
		114A00,116A00	41.7	38.3	050	050	050	050
		115A00,113A00	50.0	45.9	050	050	050	050
575-3-60	STD	118A00	17.0	17.0	047	047	047	047
		119A00	34.0	34.0	047	047	047	050
		118A00,119A00	51.0	51.0	050	050	050	050
	MED	118A00	17.0	17.0	047	047	047	047
		119A00	34.0	34.0	047	047	047	050
		118A00,119A00	51.0	51.0	050	050	050	050
	HIGH	118A00	17.0	17.0	047	047	047	047
		119A00	34.0	34.0	047	050	050	050
		118A00,119A00	51.0	51.0	050	050	050	050

LEGEND:

- APP PWR - 208 / 230V / 460V / 575V
- C.O. - Convenience outlet
- FLA - Full load amps
- IFM - Indoor fan motor
- NOM PWR - 240V / 480V / 600V
- P.E. - Power exhaust
- PWRD - Powered convenience outlet
- UNPWRD - Unpowered convenience outlet

ELECTRIC HEAT - ELECTRICAL INFORMATION (UNITS PRODUCED ON OR AFTER JULY 30, 2012)

Table 11 (cont.) - 50TC**12

2-STAGE COOLING 1-SPEED INDOOR FAN MOTOR WITHOUT FACTORY INSTALLED NON-FUSED DISCONNECT

NOM. V-PH-Hz.	IFM TYPE	ELECTRIC HEATER PART NUMBER CRHEATERXXXXXX	NOM PWR (kW)	APP PWR (kW)	SINGLE POINT KIT PART NUMBER CRSINGLEXXXXXX			
					NO C.O. or UNPWRD C.O.		w/PWRD C.O.	
					NO P.E.	w/P.E. (pwr fr/unit)	NO P.E.	w/P.E. (pwr fr/unit)
208/ 230-3-60	STD	117A00	10.4	7.8/9.6	047	047	047	047
		110A00	16.0	12.0/14.7	047	049	049	049
		112A00	32.0	24.0/29.4	049	049	049	049
		112A00,117A00	42.4	31.8/38.9	051	051	051	051
		112A00,110A00	50.0	37.6/45.9	051	051	051	051
	MED	117A00	10.4	7.8/9.6	047	047	047	049
		110A00	16.0	12.0/14.7	049	049	049	049
		112A00	32.0	24.0/29.4	049	049	049	049
		112A00,117A00	42.4	31.8/38.9	051	051	051	051
		112A00,110A00	50.0	37.6/45.9	051	051	051	051
	HIGH	117A00	10.4	7.8/9.6	047	047	049	049
		110A00	16.0	12.0/14.7	049	049	049	049
		112A00	32.0	24.0/29.4	049	049	049	049
		112A00,117A00	42.4	31.8/38.9	051	051	051	051
		112A00,110A00	50.0	37.6/45.9	051	051	051	051
460-3-60	STD	116A00	13.9	12.8	047	047	047	047
		113A00	16.5	15.2	047	047	047	047
		115A00	33.0	30.3	047	047	047	047
		114A00,116A00	41.7	38.3	050	050	050	050
		115A00,113A00	50.0	45.9	050	050	050	050
	MED	116A00	13.9	12.8	047	047	047	047
		113A00	16.5	15.2	047	047	047	047
		115A00	33.0	30.3	047	047	047	050
		114A00,116A00	41.7	38.3	050	050	050	050
		115A00,113A00	50.0	45.9	050	050	050	050
	HIGH	116A00	13.9	12.8	047	047	047	047
		113A00	16.5	15.2	047	047	047	047
		115A00	33.0	30.3	047	047	050	050
		114A00,116A00	41.7	38.3	050	050	050	050
		115A00,113A00	50.0	45.9	050	050	050	050
575-3-60	STD	118A00	17.0	17.0	047	047	047	047
		119A00	34.0	34.0	047	047	047	050
		118A00,119A00	51.0	51.0	050	050	050	050
	MED	118A00	17.0	17.0	047	047	047	047
		119A00	34.0	34.0	047	047	047	050
		118A00,119A00	51.0	51.0	050	050	050	050
	HIGH	118A00	17.0	17.0	047	047	047	047
		119A00	34.0	34.0	047	050	050	050
		118A00,119A00	51.0	51.0	050	050	050	050

LEGEND:

- APP PWR - 208 / 230V / 460V / 575V
- C.O. - Convenience outlet
- FLA - Full load amps
- IFM - Indoor fan motor
- NOM PWR - 240V / 480V / 600V
- P.E. - Power exhaust
- PWRD - Powered convenience outlet
- UNPWRD - Unpowered convenience outlet

ELECTRIC HEAT - ELECTRICAL INFORMATION (UNITS PRODUCED ON OR AFTER JULY 30, 2012)

Table 11 (cont.) - 50TC**12

2-STAGE COOLING 1-SPEED INDOOR FAN MOTOR WITH FACTORY INSTALLED NON-FUSED DISCONNECT

NOM. V-PH-Hz.	IFM TYPE	ELECTRIC HEATER PART NUMBER CRHEATERXXXXXX	NOM PWR (kW)	APP PWR (kW)	SINGLE POINT KIT PART NUMBER CRSINGLEXXXXXX			
					NO C.O. or UNPWRD C.O.		w/PWRD C.O.	
					NO P.E.	w/P.E. (pwrd fr/unit)	NO P.E.	w/P.E. (pwrd fr/unit)
208/ 230-3-60	STD	117A00	10.4	7.8/9.6	047	047	047	047
		110A00	16.0	12.0/14.7	047	049	049	049
		112A00	32.0	24.0/29.4	049	049	049	049
		112A00,117A00	42.4	31.8/38.9	051	051	051	051
		112A00,110A00	50.0	37.6/45.9	051	051	051	051
	MED	117A00	10.4	7.8/9.6	047	047	047	049
		110A00	16.0	12.0/14.7	049	049	049	049
		112A00	32.0	24.0/29.4	049	049	049	049
		112A00,117A00	42.4	31.8/38.9	051	051	051	051
		112A00,110A00	50.0	37.6/45.9	051	051	051	051
	HIGH	117A00	10.4	7.8/9.6	047	047	049	049
		110A00	16.0	12.0/14.7	049	049	049	049
		112A00	32.0	24.0/29.4	049	049	049	049
		112A00,117A00	42.4	31.8/38.9	051	051	051	051
		112A00,110A00	50.0	37.6/45.9	051	051	051	051
460-3-60	STD	116A00	13.9	12.8	047	047	047	047
		113A00	16.5	15.2	047	047	047	047
		115A00	33.0	30.3	047	047	047	047
		114A00,116A00	41.7	38.3	050	050	050	050
		115A00,113A00	50.0	45.9	050	050	050	050
	MED	116A00	13.9	12.8	047	047	047	047
		113A00	16.5	15.2	047	047	047	047
		115A00	33.0	30.3	047	047	047	050
		114A00,116A00	41.7	38.3	050	050	050	050
		115A00,113A00	50.0	45.9	050	050	050	050
	HIGH	116A00	13.9	12.8	047	047	047	047
		113A00	16.5	15.2	047	047	047	047
		115A00	33.0	30.3	047	047	050	050
		114A00,116A00	41.7	38.3	050	050	050	050
		115A00,113A00	50.0	45.9	050	050	050	050
575-3-60	STD	118A00	17.0	17.0	047	047	047	047
		119A00	34.0	34.0	047	047	047	050
		118A00,119A00	51.0	51.0	050	050	050	050
	MED	118A00	17.0	17.0	047	047	047	047
		119A00	34.0	34.0	047	047	047	050
		118A00,119A00	51.0	51.0	050	050	050	050
	HIGH	118A00	17.0	17.0	047	047	047	047
		119A00	34.0	34.0	047	050	050	050
		118A00,119A00	51.0	51.0	050	050	050	050

LEGEND:

- APP PWR - 208 / 230V / 460V / 575V
- C.O. - Convenience outlet
- FLA - Full load amps
- IFM - Indoor fan motor
- NOM PWR - 240V / 480V / 600V
- P.E. - Power exhaust
- PWRD - Powered convenience outlet
- UNPWRD - Unpowered convenience outlet

ELECTRIC HEAT - ELECTRICAL INFORMATION (UNITS PRODUCED ON OR AFTER JULY 30, 2012)

Table 11 (cont.) - 50TC**12

2-STAGE COOLING 2-SPEED INDOOR FAN MOTOR WITHOUT FACTORY INSTALLED NON-FUSED DISCONNECT

NOM. V-PH-Hz.	IFM TYPE	ELECTRIC HEATER PART NUMBER CRHEATERXXXXXX	NOM PWR (kW)	APP PWR (kW)	SINGLE POINT KIT PART NUMBER CRSINGLEXXXXXX			
					NO C.O. or UNPWRD C.O.		w/PWRD C.O.	
					NO PE.	w/PE. (pwr fr/unit)	NO PE.	w/PE. (pwr fr/unit)
208/ 230-3-60	STD	117A00	10.4	7.8/9.6	047	047	047	047
		110A00	16.0	12.0/14.7	047	049	049	049
		112A00	32.0	24.0/29.4	049	049	049	049
		112A00,117A00	42.4	31.8/38.9	051	051	051	051
		112A00,110A00	50.0	37.6/45.9	051	051	051	051
	MED	117A00	10.4	7.8/9.6	047	047	047	049
		110A00	16.0	12.0/14.7	049	049	049	049
		112A00	32.0	24.0/29.4	049	049	049	049
		112A00,117A00	42.4	31.8/38.9	051	051	051	051
		112A00,110A00	50.0	37.6/45.9	051	051	051	051
	HIGH	117A00	10.4	7.8/9.6	047	047	049	049
		110A00	16.0	12.0/14.7	049	049	049	049
		112A00	32.0	24.0/29.4	049	049	049	049
		112A00,117A00	42.4	31.8/38.9	051	051	051	051
		112A00,110A00	50.0	37.6/45.9	051	051	051	051
460-3-60	STD	116A00	13.9	12.8	047	047	047	047
		113A00	16.5	15.2	047	047	047	047
		115A00	33.0	30.3	047	047	047	047
		114A00,116A00	41.7	38.3	050	050	050	050
		115A00,113A00	50.0	45.9	050	050	050	050
	MED	116A00	13.9	12.8	047	047	047	047
		113A00	16.5	15.2	047	047	047	047
		115A00	33.0	30.3	047	047	047	050
		114A00,116A00	41.7	38.3	050	050	050	050
		115A00,113A00	50.0	45.9	050	050	050	050
	HIGH	116A00	13.9	12.8	047	047	047	047
		113A00	16.5	15.2	047	047	047	047
		115A00	33.0	30.3	047	047	050	050
		114A00,116A00	41.7	38.3	050	050	050	050
		115A00,113A00	50.0	45.9	050	050	050	050
575-3-60	STD	118A00	17.0	17.0	047	047	047	047
		119A00	34.0	34.0	047	050	047	050
		118A00,119A00	51.0	51.0	050	050	050	050
	MED	118A00	17.0	17.0	047	047	047	047
		119A00	34.0	34.0	047	050	047	050
		118A00,119A00	51.0	51.0	050	050	050	050
	HIGH	118A00	17.0	17.0	047	047	047	047
		119A00	34.0	34.0	047	050	050	050
		118A00,119A00	51.0	51.0	050	050	050	050

LEGEND:

- APP PWR - 208 / 230V / 460V / 575V
- C.O. - Convenience outlet
- FLA - Full load amps
- IFM - Indoor fan motor
- NOM PWR - 240V / 480V / 600V
- PE. - Power exhaust
- PWRD - Powered convenience outlet
- UNPWRD - Unpowered convenience outlet

ELECTRIC HEAT - ELECTRICAL INFORMATION (UNITS PRODUCED ON OR AFTER JULY 30, 2012)

Table 11 (cont.) - 50TC**14

2-STAGE COOLING 1-SPEED INDOOR FAN MOTOR WITHOUT FACTORY INSTALLED NON-FUSED DISCONNECT

NOM. V-PH-Hz.	IFM TYPE	ELECTRIC HEATER PART NUMBER CRHEATERXXXXXX	NOM PWR (kW)	APP PWR (kW)	SINGLE POINT KIT PART NUMBER CRSINGLEXXXXXX			
					NO C.O. or UNPWRD C.O.		w/PWRD C.O.	
					NO P.E.	w/P.E. (pwrd fr/unit)	NO P.E.	w/P.E. (pwrd fr/unit)
208/ 230-3-60	STD	117A00	10.4	7.8/9.6	049	049	049	049
		110A00	16.0	12.0/14.7	049	049	049	049
		112A00	32.0	24.0/29.4	049	049	049	049
		112A00,117A00	42.4	31.8/38.9	051	051	051	051
		112A00,110A00	50.0	37.6/45.9	051	051	051	051
	MED	117A00	10.4	7.8/9.6	049	049	049	049
		110A00	16.0	12.0/14.7	049	049	049	049
		112A00	32.0	24.0/29.4	049	049	049	049
		112A00,117A00	42.4	31.8/38.9	051	051	051	051
		112A00,110A00	50.0	37.6/45.9	051	051	051	051
	HIGH	117A00	10.4	7.8/9.6	049	049	049	049
		110A00	16.0	12.0/14.7	049	049	049	049
		112A00	32.0	24.0/29.4	049	049	049	049
		112A00,117A00	42.4	31.8/38.9	051	051	051	051
		112A00,110A00	50.0	37.6/45.9	051	051	051	051
460-3-60	STD	116A00	13.9	12.8	047	047	047	047
		113A00	16.5	15.2	047	047	047	047
		115A00	33.0	30.3	047	047	047	047
		114A00,116A00	41.7	38.3	050	050	050	050
		115A00,113A00	50.0	45.9	050	050	050	050
	MED	116A00	13.9	12.8	047	047	047	047
		113A00	16.5	15.2	047	047	047	047
		115A00	33.0	30.3	047	047	047	050
		114A00,116A00	41.7	38.3	050	050	050	050
		115A00,113A00	50.0	45.9	050	050	050	050
	HIGH	116A00	13.9	12.8	047	047	047	047
		113A00	16.5	15.2	047	047	047	047
		115A00	33.0	30.3	047	047	050	050
		114A00,116A00	41.7	38.3	050	050	050	050
		115A00,113A00	50.0	45.9	050	050	050	050
575-3-60	STD	118A00	17.0	17.0	047	047	047	047
		119A00	34.0	34.0	047	047	047	050
		118A00,119A00	51.0	51.0	050	050	050	050
	MED	118A00	17.0	17.0	047	047	047	047
		119A00	34.0	34.0	047	047	047	050
		118A00,119A00	51.0	51.0	050	050	050	050
	HIGH	118A00	17.0	17.0	047	047	047	047
		119A00	34.0	34.0	047	050	050	050
		118A00,119A00	51.0	51.0	050	050	050	050

LEGEND:

- APP PWR - 208 / 230V / 460V / 575V
- C.O. - Convenience outlet
- FLA - Full load amps
- IFM - Indoor fan motor
- NOM PWR - 240V / 480V / 600V
- P.E. - Power exhaust
- PWRD - Powered convenience outlet
- UNPWRD - Unpowered convenience outlet

ELECTRIC HEAT - ELECTRICAL INFORMATION (UNITS PRODUCED ON OR AFTER JULY 30, 2012)

Table 11 (cont.) - 50TC**14

2-STAGE COOLING 1-SPEED INDOOR FAN MOTOR WITH FACTORY INSTALLED NON-FUSED DISCONNECT

NOM. V-PH-Hz.	IFM TYPE	ELECTRIC HEATER PART NUMBER CRHEATERXXXXXX	NOM PWR (kW)	APP PWR (kW)	SINGLE POINT KIT PART NUMBER CRSINGLEXXXXXX			
					NO C.O. or UNPWRD C.O.		w/PWRD C.O.	
					NO P.E.	w/P.E. (pwrd fr/unit)	NO P.E.	w/P.E. (pwrd fr/unit)
208/ 230-3-60	STD	117A00	10.4	7.8/9.6	049	049	049	049
		110A00	16.0	12.0/14.7	049	049	049	049
		112A00	32.0	24.0/29.4	049	049	049	049
		112A00,117A00	42.4	31.8/38.9	051	051	051	051
		112A00,110A00	50.0	37.6/45.9	051	051	051	051
	MED	117A00	10.4	7.8/9.6	049	049	049	049
		110A00	16.0	12.0/14.7	049	049	049	049
		112A00	32.0	24.0/29.4	049	049	049	049
		112A00,117A00	42.4	31.8/38.9	051	051	051	051
		112A00,110A00	50.0	37.6/45.9	051	051	051	051
	HIGH	117A00	10.4	7.8/9.6	049	049	049	049
		110A00	16.0	12.0/14.7	049	049	049	049
		112A00	32.0	24.0/29.4	049	049	049	049
		112A00,117A00	42.4	31.8/38.9	051	051	051	051
		112A00,110A00	50.0	37.6/45.9	051	051	051	051
460-3-60	STD	116A00	13.9	12.8	047	047	047	047
		113A00	16.5	15.2	047	047	047	047
		115A00	33.0	30.3	047	047	047	047
		114A00,116A00	41.7	38.3	050	050	050	050
		115A00,113A00	50.0	45.9	050	050	050	050
	MED	116A00	13.9	12.8	047	047	047	047
		113A00	16.5	15.2	047	047	047	047
		115A00	33.0	30.3	047	047	047	050
		114A00,116A00	41.7	38.3	050	050	050	050
		115A00,113A00	50.0	45.9	050	050	050	050
	HIGH	116A00	13.9	12.8	047	047	047	047
		113A00	16.5	15.2	047	047	047	047
		115A00	33.0	30.3	047	047	050	050
		114A00,116A00	41.7	38.3	050	050	050	050
		115A00,113A00	50.0	45.9	050	050	050	050
575-3-60	STD	118A00	17.0	17.0	047	047	047	047
		119A00	34.0	34.0	047	047	047	050
		118A00,119A00	51.0	51.0	050	050	050	050
	MED	118A00	17.0	17.0	047	047	047	047
		119A00	34.0	34.0	047	047	047	050
		118A00,119A00	51.0	51.0	050	050	050	050
	HIGH	118A00	17.0	17.0	047	047	047	047
		119A00	34.0	34.0	047	050	050	050
		118A00,119A00	51.0	51.0	050	050	050	050

LEGEND:

- APP PWR - 208 / 230V / 460V / 575V
- C.O. - Convenience outlet
- FLA - Full load amps
- IFM - Indoor fan motor
- NOM PWR - 240V / 480V / 600V
- P.E. - Power exhaust
- PWRD - Powered convenience outlet
- UNPWRD - Unpowered convenience outlet

ELECTRIC HEAT - ELECTRICAL INFORMATION (UNITS PRODUCED ON OR AFTER JULY 30, 2012)

Table 11 (cont.) - 50TC**14

2-STAGE COOLING 2-SPEED INDOOR FAN MOTOR WITHOUT FACTORY INSTALLED NON-FUSED DISCONNECT

NOM. V-PH-Hz.	IFM TYPE	ELECTRIC HEATER PART NUMBER CRHEATERXXXXXX	NOM PWR (kW)	APP PWR (kW)	SINGLE POINT KIT PART NUMBER CRSINGLEXXXXXX			
					NO C.O. or UNPWRD C.O.		w/PWRD C.O.	
					NO P.E.	w/P.E. (pwr fr/unit)	NO P.E.	w/P.E. (pwr fr/unit)
208/ 230-3-60	STD	117A00	10.4	7.8/9.6	049	049	049	049
		110A00	16.0	12.0/14.7	049	049	049	049
		112A00	32.0	24.0/29.4	049	049	049	049
		112A00,117A00	42.4	31.8/38.9	051	051	051	051
		112A00,110A00	50.0	37.6/45.9	051	051	051	051
	MED	117A00	10.4	7.8/9.6	049	049	049	049
		110A00	16.0	12.0/14.7	049	049	049	049
		112A00	32.0	24.0/29.4	049	049	049	049
		112A00,117A00	42.4	31.8/38.9	051	051	051	051
		112A00,110A00	50.0	37.6/45.9	051	051	051	051
	HIGH	117A00	10.4	7.8/9.6	049	049	049	049
		110A00	16.0	12.0/14.7	049	049	049	049
		112A00	32.0	24.0/29.4	049	049	049	049
		112A00,117A00	42.4	31.8/38.9	051	051	051	051
		112A00,110A00	50.0	37.6/45.9	051	051	051	051
460-3-60	STD	116A00	13.9	12.8	047	047	047	047
		113A00	16.5	15.2	047	047	047	047
		115A00	33.0	30.3	047	047	047	047
		114A00,116A00	41.7	38.3	050	050	050	050
		115A00,113A00	50.0	45.9	050	050	050	050
	MED	116A00	13.9	12.8	047	047	047	047
		113A00	16.5	15.2	047	047	047	047
		115A00	33.0	30.3	047	047	047	050
		114A00,116A00	41.7	38.3	050	050	050	050
		115A00,113A00	50.0	45.9	050	050	050	050
	HIGH	116A00	13.9	12.8	047	047	047	047
		113A00	16.5	15.2	047	047	047	047
		115A00	33.0	30.3	047	047	050	050
		114A00,116A00	41.7	38.3	050	050	050	050
		115A00,113A00	50.0	45.9	050	050	050	050
575-3-60	STD	118A00	17.0	17.0	047	047	047	047
		119A00	34.0	34.0	047	050	047	050
		118A00,119A00	51.0	51.0	050	050	050	050
	MED	118A00	17.0	17.0	047	047	047	047
		119A00	34.0	34.0	047	050	047	050
		118A00,119A00	51.0	51.0	050	050	050	050
	HIGH	118A00	17.0	17.0	047	047	047	047
		119A00	34.0	34.0	047	050	050	050
		118A00,119A00	51.0	51.0	050	050	050	050

LEGEND:

- APP PWR - 208 / 230V / 460V / 575V
- C.O. - Convenience outlet
- FLA - Full load amps
- IFM - Indoor fan motor
- NOM PWR - 240V / 480V / 600V
- P.E. - Power exhaust
- PWRD - Powered convenience outlet
- UNPWRD - Unpowered convenience outlet

ELECTRIC HEAT - ELECTRICAL INFORMATION (UNITS PRODUCED ON OR AFTER JULY 30, 2012)

Table 11 (cont.) - 50TC**16

2-STAGE COOLING 1-SPEED INDOOR FAN MOTOR WITHOUT FACTORY INSTALLED NON-FUSED DISCONNECT

NOM. V-PH-Hz.	IFM TYPE	ELECTRIC HEATER PART NUMBER CRHEATERXXXXXX	NOM PWR (kW)	APP PWR (kW)	SINGLE POINT KIT PART NUMBER CRSINGLEXXXXXX			
					NO C.O. or UNPWRD C.O.		w/PWRD C.O.	
					NO P.E.	w/P.E. (pwrd fr/unit)	NO P.E.	w/P.E. (pwrd fr/unit)
208/ 230-3-60	STD	291A00	16.5	12.4/15.2	049	049	049	049
		294A00	33.5	25.2/30.8	049	049	049	049
		288A00,294A00	43.5	32.7/40.0	051	051	051	051
		291A00,294A00	50.0	37.6/45.9	051	051	051	051
		294A00,294A00	67.0	50.3/61.5	053	053	053	053
	MED	291A00	16.5	12.4/15.2	049	049	049	049
		294A00	33.5	25.2/30.8	049	049	049	049
		288A00,294A00	43.5	32.7/40.0	051	051	051	051
		291A00,294A00	50.0	37.6/45.9	051	051	051	051
		294A00,294A00	67.0	50.3/61.5	053	053	053	053
	HIGH	291A00	16.5	12.4/15.2	049	049	049	049
		294A00	33.5	25.2/30.8	049	049	049	049
288A00,294A00		43.5	32.7/40.0	051	051	051	051	
291A00,294A00		50.0	37.6/45.9	051	051	051	051	
294A00,294A00		67.0	50.3/61.5	053	053	053	053	
460-3-60	STD	292A00	16.5	15.2	-	-	-	-
		295A00	33.5	30.8	047	047	047	050
		289A00,295A00	43.5	40.0	050	050	050	050
		292A00,295A00	50.0	45.9	050	050	050	050
		295A00,295A00	67.0	61.5	050	050	050	050
	MED	292A00	16.5	15.2	-	-	-	-
		295A00	33.5	30.8	047	047	047	050
		289A00,295A00	43.5	40.0	050	050	050	050
		292A00,295A00	50.0	45.9	050	050	050	050
		295A00,295A00	67.0	61.5	050	050	050	050
	HIGH	292A00	16.5	15.2	-	-	-	-
		295A00	33.5	30.8	050	050	050	050
289A00,295A00		43.5	40.0	050	050	050	050	
292A00,295A00		50.0	45.9	050	050	050	050	
295A00,295A00		67.0	61.5	050	050	050	050	
575-3-60	STD	293A00	16.5	15.2	-	-	-	-
		296A00	33.5	30.8	047	047	047	047
		290A00,296A00	43.5	40.0	047	050	047	050
		293A00,296A00	50.0	45.9	047	047	047	047
		296A00,296A00	67.0	61.5	050	050	050	050
	MED	293A00	16.5	15.2	-	-	-	-
		296A00	33.5	30.8	047	047	047	047
		290A00,296A00	43.5	40.0	047	050	047	050
		293A00,296A00	50.0	45.9	047	047	047	047
		296A00,296A00	67.0	61.5	050	050	050	050
	HIGH	293A00	16.5	15.2	-	-	-	-
		296A00	33.5	30.8	047	047	047	047
290A00,296A00		43.5	40.0	050	050	050	050	
293A00,296A00		50.0	45.9	050	050	050	050	
296A00,296A00		67.0	61.5	050	050	050	050	

LEGEND:

- APP PWR - 208 / 230V / 460V / 575V
- C.O. - Convenience outlet
- FLA - Full load amps
- IFM - Indoor fan motor
- NOM PWR - 240V / 480V / 600V
- P.E. - Power exhaust
- PWRD - Powered convenience outlet
- UNPWRD - Unpowered convenience outlet

ELECTRIC HEAT - ELECTRICAL INFORMATION (UNITS PRODUCED ON OR AFTER JULY 30, 2012)

Table 11 (cont.) - 50TC**16

2-STAGE COOLING 1-SPEED INDOOR FAN MOTOR WITH FACTORY INSTALLED NON-FUSED DISCONNECT

NOM. V-PH-Hz.	IFM TYPE	ELECTRIC HEATER PART NUMBER CRHEATERXXXXXX	NOM PWR (kW)	APP PWR (kW)	SINGLE POINT KIT PART NUMBER CRSINGLEXXXXXX			
					NO C.O. or UNPWRD C.O.		w/PWRD C.O.	
					NO P.E.	w/PE. (pwrd fr/unit)	NO P.E.	w/PE. (pwrd fr/unit)
208/ 230-3-60	STD	291A00	16.5	12.4/15.2	049	049	049	049
		294A00	33.5	25.2/30.8	049	049	049	049
		288A00,294A00	43.5	32.7/40.0	051	051	051	051
		291A00,294A00	50.0	37.6/45.9	051	051	051	051
		294A00,294A00	67.0	50.3/61.5	053	053	053	053
	MED	291A00	16.5	12.4/15.2	049	049	049	049
		294A00	33.5	25.2/30.8	049	049	049	049
		288A00,294A00	43.5	32.7/40.0	051	051	051	051
		291A00,294A00	50.0	37.6/45.9	051	051	051	051
		294A00,294A00	67.0	50.3/61.5	053	053	053	053
	HIGH	291A00	16.5	12.4/15.2	049	049	049	049
		294A00	33.5	25.2/30.8	049	049	049	049
288A00,294A00		43.5	32.7/40.0	051	051	051	051	
291A00,294A00		50.0	37.6/45.9	051	051	051	051	
294A00,294A00		67.0	50.3/61.5	053	053	053	053	
460-3-60	STD	292A00	16.5	15.2	-	-	-	-
		295A00	33.5	30.8	047	047	047	050
		289A00,295A00	43.5	40.0	050	050	050	050
		292A00,295A00	50.0	45.9	050	050	050	050
		295A00,295A00	67.0	61.5	050	050	050	050
	MED	292A00	16.5	15.2	-	-	-	-
		295A00	33.5	30.8	047	047	047	050
		289A00,295A00	43.5	40.0	050	050	050	050
		292A00,295A00	50.0	45.9	050	050	050	050
		295A00,295A00	67.0	61.5	050	050	050	050
	HIGH	292A00	16.5	15.2	-	-	-	-
		295A00	33.5	30.8	050	050	050	050
289A00,295A00		43.5	40.0	050	050	050	050	
292A00,295A00		50.0	45.9	050	050	050	050	
295A00,295A00		67.0	61.5	050	050	050	050	
575-3-60	STD	293A00	16.5	15.2	-	-	-	-
		296A00	33.5	30.8	047	047	047	047
		290A00,296A00	43.5	40.0	047	050	047	050
		293A00,296A00	50.0	45.9	047	047	047	047
		296A00,296A00	67.0	61.5	050	050	050	050
	MED	293A00	16.5	15.2	-	-	-	-
		296A00	33.5	30.8	047	047	047	047
		290A00,296A00	43.5	40.0	047	050	047	050
		293A00,296A00	50.0	45.9	047	047	047	047
		296A00,296A00	67.0	61.5	050	050	050	050
	HIGH	293A00	16.5	15.2	-	-	-	-
		296A00	33.5	30.8	047	047	047	047
290A00,296A00		43.5	40.0	050	050	050	050	
293A00,296A00		50.0	45.9	050	050	050	050	
296A00,296A00		67.0	61.5	050	050	050	050	

LEGEND:

- APP PWR - 208 / 230V / 460V / 575V
- C.O. - Convenience outlet
- FLA - Full load amps
- IFM - Indoor fan motor
- NOM PWR - 240V / 480V / 600V
- P.E. - Power exhaust
- PWRD - Powered convenience outlet
- UNPWRD - Unpowered convenience outlet

ELECTRIC HEAT - ELECTRICAL INFORMATION (UNITS PRODUCED ON OR AFTER JULY 30, 2012)

Table 11 (cont.) - 50TC**16

2-STAGE COOLING 2-SPEED INDOOR FAN MOTOR WITHOUT FACTORY INSTALLED NON-FUSED DISCONNECT

NOM. V-PH-Hz.	IFM TYPE	ELECTRIC HEATER PART NUMBER CRHEATERXXXXXX	NOM PWR (kW)	APP PWR (kW)	SINGLE POINT KIT PART NUMBER CRSINGLEXXXXXX			
					NO C.O. or UNPWRD C.O.		w/PWRD C.O.	
					NO P.E.	w/P.E. (pwrd fr/unit)	NO P.E.	w/P.E. (pwrd fr/unit)
208/ 230-3-60	STD	291A00	16.5	12.4/15.2	049	049	049	049
		294A00	33.5	25.2/30.8	049	049	049	049
		288A00,294A00	43.5	32.7/40.0	051	051	051	051
		291A00,294A00	50.0	37.6/45.9	051	051	051	051
		294A00,294A00	67.0	50.3/61.5	053	053	053	053
	MED	291A00	16.5	12.4/15.2	049	049	049	049
		294A00	33.5	25.2/30.8	049	049	049	049
		288A00,294A00	43.5	32.7/40.0	051	051	051	051
		291A00,294A00	50.0	37.6/45.9	051	051	051	051
		294A00,294A00	67.0	50.3/61.5	053	053	053	053
	HIGH	294A00	33.5	25.2/30.8	049	049	049	049
		288A00,294A00	43.5	32.7/40.0	051	051	051	051
291A00,294A00		50.0	37.6/45.9	051	051	051	051	
294A00,294A00		67.0	50.3/61.5	053	053	053	053	
460-3-60	STD	292A00	16.5	15.2	-	-	-	-
		295A00	33.5	30.8	047	047	047	050
		289A00,295A00	43.5	40.0	050	050	050	050
		292A00,295A00	50.0	45.9	050	050	050	050
		295A00,295A00	67.0	61.5	050	050	050	050
	MED	292A00	16.5	15.2	-	-	-	-
		295A00	33.5	30.8	047	047	047	050
		289A00,295A00	43.5	40.0	050	050	050	050
		292A00,295A00	50.0	45.9	050	050	050	050
	HIGH	295A00,295A00	67.0	61.5	050	050	050	050
		292A00	16.5	15.2	-	-	-	-
		295A00	33.5	30.8	050	050	050	050
289A00,295A00		43.5	40.0	050	050	050	050	
575-3-60	STD	292A00	50.0	45.9	050	050	050	050
		295A00,295A00	67.0	61.5	050	050	050	050
		293A00	16.5	15.2	-	-	-	-
		296A00	33.5	30.8	047	047	047	047
		290A00,296A00	43.5	40.0	047	050	047	050
	MED	293A00,296A00	50.0	45.9	047	047	047	050
		296A00,296A00	67.0	61.5	050	050	050	050
		293A00	16.5	15.2	-	-	-	-
		296A00	33.5	30.8	047	047	047	047
	HIGH	290A00,296A00	43.5	40.0	050	050	050	050
		293A00,296A00	50.0	45.9	050	050	050	050
		296A00,296A00	67.0	61.5	050	050	050	050
293A00		16.5	15.2	-	-	-	-	

LEGEND:

- APP PWR - 208 / 230V / 460V / 575V
- C.O. - Convenience outlet
- FLA - Full load amps
- IFM - Indoor fan motor
- NOM PWR - 240V / 480V / 600V
- P.E. - Power exhaust
- PWRD - Powered convenience outlet
- UNPWRD - Unpowered convenience outlet

ELECTRICAL INFORMATION (UNITS PRODUCED ON OR AFTER JULY 30, 2012) cont.

Table 12 – UNIT WIRE/FUSE OR HACR BREAKER SIZING DATA

UNIT	NO M, V-Ph-HZ	ELEC. HTR				NO C.O. or UNPWR C.O.												
		CRHEATER***A00	Nom (kW)	FLA	NO PE.			w/ P.E. (pwrd fr/unit)			NO PE.			w/ PWR C.O.				
					MCA	MAX FUSE or HACR BRKR	DISC. SIZE FLA LRA	MCA	MAX FUSE or HACR BRKR	DISC. SIZE FLA LRA	MCA	MAX FUSE or HACR BRKR	DISC. SIZE FLA LRA	MCA	MAX FUSE or HACR BRKR	DISC. SIZE FLA LRA		
50TC**04	208/230-1-60	NONE	-	-	28	40	26	95	30	45	29	97	32	100	34	50	34	102
		101A	3.3/4.4	15.9/18.3	28/29	40/40	26/27	95/95	30/32	45/45	29/29	97/97	32/32	100/100	35/38	50/50	34/34	102/102
		102A	4.9/6.5	23.5/27.1	36/40	40/45	33/37	95/95	38/43	45/45	35/39	97/97	38/42	100/100	44/49	50/50	40/45	102/102
		103B	6.5/8.7	31.4/36.3	49/52	50/60	42/47	95/95	48/54	50/60	44/50	97/97	47/53	100/100	54/60	60/60	49/55	102/102
		104B	7.9/10.5	37.9/43.8	54/61	60/70	49/56	95/95	56/64	60/70	51/58	97/97	55/62	100/100	62/70	70/70	57/64	102/102
		102A+102A	9.8/13.0	46.9/54.2	65/74	70/80	60/68	95/95	68/77	70/80	62/70	97/97	65/73	100/100	74/83	80/90	67/76	102/102
		NONE	-	-	28	40	26	95	30	45	29	97	32	100	34	50	34	102
		101A	3.3/4.4	15.9/18.3	28/29	40/40	26/27	95/95	30/32	45/45	29/29	97/97	32/32	100/100	35/38	50/50	34/34	102/102
		102A	4.9/6.5	23.5/27.1	36/40	40/45	33/37	95/95	38/43	45/45	35/39	97/97	38/42	100/100	44/49	50/50	40/45	102/102
		103B	6.5/8.7	31.4/36.3	49/52	50/60	42/47	95/95	48/54	50/60	44/50	97/97	47/53	100/100	54/60	60/60	49/55	102/102
104B	7.9/10.5	37.9/43.8	54/61	60/70	49/56	95/95	56/64	60/70	51/58	97/97	55/62	100/100	62/70	70/70	57/64	102/102		
102A+102A	9.8/13.0	46.9/54.2	65/74	70/80	60/68	95/95	68/77	70/80	62/70	97/97	65/73	100/100	74/83	80/90	67/76	102/102		
208/230-3-60	208/230-3-60	NONE	-	-	20	30	20	96	22	30	22	98	25	101	27	30	27	103
		101A	3.3/4.4	9.2/10.6	20/20	30/30	20/20	96/96	22/23	30/30	22/22	98/98	25/26	101/101	27/29	30/30	27/27	103/103
		102A	4.9/6.5	13.6/15.6	24/26	30/30	22/24	96/96	26/29	30/30	24/26	98/98	30/32	101/101	32/35	35/35	29/32	103/103
		103B	6.5/8.7	18.1/20.9	30/33	30/35	27/30	96/96	32/35	35/40	29/32	98/98	36/39	101/101	38/41	40/45	35/38	103/103
		104B	7.9/10.5	21.9/25.3	34/39	35/40	31/35	96/96	37/41	40/45	33/37	98/98	40/45	101/101	43/47	45/50	39/43	103/103
		105A	12.0/16.0	33.4/38.5	49/55	50/60	44/50	96/96	51/57	60/60	47/52	98/98	55/61	101/101	57/63	60/70	52/58	103/103
		NONE	-	-	20	30	20	96	22	30	22	98	25	101	27	30	27	103
		101A	3.3/4.4	9.2/10.6	20/20	30/30	20/20	96/96	22/23	30/30	22/22	98/98	25/26	101/101	27/29	30/30	27/27	103/103
		102A	4.9/6.5	13.6/15.6	24/26	30/30	22/24	96/96	26/29	30/30	24/26	98/98	30/32	101/101	32/35	35/35	29/32	103/103
		103B	6.5/8.7	18.1/20.9	30/33	30/35	27/30	96/96	32/35	35/40	29/32	98/98	36/39	101/101	38/41	40/45	35/38	103/103
104B	7.9/10.5	21.9/25.3	34/39	35/40	31/35	96/96	37/41	40/45	33/37	98/98	40/45	101/101	43/47	45/50	39/43	103/103		
105A	12.0/16.0	33.4/38.5	49/55	50/60	44/50	96/96	51/57	60/60	47/52	98/98	55/61	101/101	57/63	60/70	52/58	103/103		
208/230-1-60	208/230-1-60	NONE	-	-	22	30	22	134	24	30	24	136	27	139	29	35	29	141
		101A	3.3/4.4	9.2/10.6	22/22	30/30	22/21	134/134	24/24	30/30	24/24	136/136	27/28	139/139	29/30	35/35	29/29	141/141
		102A	4.9/6.5	13.6/15.6	26/28	30/30	24/26	134/134	28/31	30/35	26/28	136/136	32/34	139/139	34/37	35/40	31/33	141/141
		103B	6.5/8.7	18.1/20.9	32/35	35/35	29/32	134/134	34/37	35/40	31/34	136/136	38/41	139/139	40/43	40/45	36/39	141/141
		104B	7.9/10.5	21.9/25.3	36/40	40/40	33/37	134/134	39/43	40/45	35/39	136/136	42/46	139/139	45/49	45/50	41/45	141/141
		105A	12.0/16.0	33.4/38.5	51/57	60/60	46/52	134/134	53/59	60/60	49/54	136/136	57/63	139/139	59/65	60/70	54/60	141/141

**ELECTRICAL INFORMATION
(UNITS PRODUCED ON OR AFTER JULY 30, 2012) cont.**

Table 12 - Unit Wire/Fuse or HACR Breaker Sizing Data (cont.)

UNIT	NO M, V, Ph-HZ	ELEC. HTR			NO C.O. or UNPWR C.O.										w/ PWRD C.O.									
		IFM TYPE	CRHEATER***A00	Nom (kW)	FLA	NO PE.			w/ PE. (pwrdr fr/unit)			NO PE.			w/ PWRD C.O.			w/ PE. (pwrdr fr/unit)						
						MCA	MAX FUSE or HACR BRKR	DISC. SIZE FLA LRA	MCA	MAX FUSE or HACR BRKR	DISC. SIZE FLA LRA	MCA	MAX FUSE or HACR BRKR	DISC. SIZE FLA LRA	MCA	MAX FUSE or HACR BRKR	DISC. SIZE FLA LRA							
50TC**04	460-3-60	STD	NONE	-	-	11	15	11	49	12	50	13	15	13	51	14	20	14	52					
			106A	6.0	7.2	11	15	11	49	12	50	14	15	14	51	17	20	15	52					
			107A	8.8	10.6	15	20	15	49	16	50	18	20	18	51	21	25	19	52					
			108A	11.5	13.8	19	25	19	49	20	50	24	25	21	51	25	25	23	52					
			109A	14.0	16.8	22	25	22	49	23	50	27	30	25	51	29	30	26	52					
575-3-60	460-3-60	HIGH	NONE	-	-	12	15	12	68	13	69	14	15	13	70	15	20	15	71					
			106A	6.0	7.2	12	15	12	68	13	69	14	15	13	70	16	20	16	71					
			107A	8.8	10.6	16	20	16	68	17	69	19	21	19	70	22	25	20	71					
			108A	11.5	13.8	20	25	20	68	21	69	25	25	22	70	26	30	23	71					
			109A	14.0	16.8	23	30	23	68	24	69	28	30	26	70	30	30	27	71					
575-3-60	460-3-60	STD	NONE	-	-	8	15	8	46	10	48	10	15	10	48	12	15	12	50					
			NONE	-	-	8	15	8	46	10	48	10	15	10	48	12	15	12	50					
			NONE	-	-	8	15	7	50	10	52	10	15	9	52	11	15	12	54					

ELECTRICAL INFORMATION (UNITS PRODUCED ON OR AFTER JULY 30, 2012) cont.

Table 12 - UNIT WIRE/FUSE OR HACR BREAKER SIZING DATA (cont.)

UNIT	NO M, V-PH-HZ	ELEC. HTR				NO C.O. or UNPWR C.O.														
		CRHEATER***A00	Nom (kW)	FLA	NO PE.			w/ PE. (pwrld fr/unit)			NO PE.			w/ PWRD C.O.						
					MCA	MAX FUSE or HACR BRKR	DISC. SIZE FLA LRA	MCA	MAX FUSE or HACR BRKR	DISC. SIZE FLA LRA	MCA	MAX FUSE or HACR BRKR	DISC. SIZE FLA LRA	MCA	MAX FUSE or HACR BRKR	DISC. SIZE FLA LRA				
50TC**05	208/230-1-60	NONE	-	-	34	50	32	133	36	50	35	135	39	60	38	138	41	60	40	140
		101A	3.3/4.4	15.9/18.3	34/34	50/50	32/32	133/133	36/36	50/50	35/35	135/135	39/39	60/60	38/38	138/138	41/41	60/60	40/40	140/140
		103B	6.5/8.7	31.4/36.3	46/52	50/60	42/47	133/133	48/54	50/60	44/50	135/135	52/58	60/60	47/53	138/138	54/60	60/60	49/55	140/140
		102A+102A	9.8/13.0	46.9/54.2	65/74	70/80	60/68	133/133	68/77	70/80	62/70	135/135	71/80	80/80	65/73	138/138	74/83	80/90	67/76	140/140
		103B+103B	13.1/17.4	62.8/72.5	85/97	90/100	78/89	133/133	87/100	90/100	80/91	135/135	91/103	100/110	83/95	138/138	93/106	100/110	86/97	140/140
		104B+104B	15.8/21.0	75.8/87.5	101/116	110/125	93/106	133/133	104/118	110/125	95/108	135/135	107/122	110/125	98/112	138/138	110/124	110/125	101/114	140/140
		NONE	-	-	34	50	32	133	36	50	35	135	39	60	38	138	41	60	40	140
		101A	3.3/4.4	15.9/18.3	34/34	50/50	32/32	133/133	36/36	50/50	35/35	135/135	39/39	60/60	38/38	138/138	41/41	60/60	40/40	140/140
		103B	6.5/8.7	31.4/36.3	46/52	50/60	42/47	133/133	48/54	50/60	44/50	135/135	52/58	60/60	47/53	138/138	54/60	60/60	49/55	140/140
		102A+102A	9.8/13.0	46.9/54.2	65/74	70/80	60/68	133/133	68/77	70/80	62/70	135/135	71/80	80/80	65/73	138/138	74/83	80/90	67/76	140/140
103B+103B	13.1/17.4	62.8/72.5	85/97	90/100	78/89	133/133	87/100	90/100	80/91	135/135	91/103	100/110	83/95	138/138	93/106	100/110	86/97	140/140		
104B+104B	15.8/21.0	75.8/87.5	101/116	110/125	93/106	133/133	104/118	110/125	95/108	135/135	107/122	110/125	98/112	138/138	110/124	110/125	101/114	140/140		
208/230-3-60	208/230-3-60	NONE	-	-	24	30	23	106	26	30	26	108	29	40	29	111	31	40	31	113
		102A	4.9/6.5	13.6/15.6	24/26	30/30	23/24	106/106	26/29	30/30	26/26	108/108	30/32	40/40	29/29	111/111	32/35	40/40	31/32	113/113
		103B	6.5/8.7	18.1/20.9	30/33	30/35	27/30	106/106	32/35	35/40	29/32	108/108	36/39	40/40	32/36	111/111	38/41	40/45	35/38	113/113
		105A	12.0/16.0	33.4/38.5	49/55	50/60	44/50	106/106	51/57	60/60	47/52	108/108	55/61	60/70	50/56	111/111	57/63	60/70	52/58	113/113
		104B+104B	15.8/21.0	43.8/50.5	62/70	70/70	56/64	106/106	64/72	70/80	59/66	108/108	68/76	70/80	62/70	111/111	70/78	70/80	64/72	113/113
		NONE	-	-	24	30	23	106	26	30	26	108	29	40	29	111	31	40	31	113
		102A	4.9/6.5	13.6/15.6	24/26	30/30	23/24	106/106	26/29	30/30	26/26	108/108	30/32	40/40	29/29	111/111	32/35	40/40	31/32	113/113
		103B	6.5/8.7	18.1/20.9	30/33	30/35	27/30	106/106	32/35	35/40	29/32	108/108	36/39	40/40	32/36	111/111	38/41	40/45	35/38	113/113
		105A	12.0/16.0	33.4/38.5	49/55	50/60	44/50	106/106	51/57	60/60	47/52	108/108	55/61	60/70	50/56	111/111	57/63	60/70	52/58	113/113
		104B+104B	15.8/21.0	43.8/50.5	62/70	70/70	56/64	106/106	64/72	70/80	59/66	108/108	68/76	70/80	62/70	111/111	70/78	70/80	64/72	113/113
208/230-3-60	208/230-3-60	NONE	-	-	24	30	23	106	26	30	26	108	29	40	29	111	31	40	31	113
		102A	4.9/6.5	13.6/15.6	24/26	30/30	23/24	106/106	26/29	30/30	26/26	108/108	30/32	40/40	29/29	111/111	32/35	40/40	31/32	113/113
		103B	6.5/8.7	18.1/20.9	32/35	35/35	29/32	144/144	34/37	40/40	31/34	146/146	38/41	40/45	34/37	149/149	40/43	45/45	36/39	151/151
		105A	12.0/16.0	33.4/38.5	51/57	60/60	46/52	144/144	53/59	60/60	49/54	146/146	57/63	60/70	52/58	149/149	59/65	60/70	54/60	151/151
		104B+104B	15.8/21.0	43.8/50.5	64/72	70/80	58/66	144/144	66/74	70/80	60/68	146/146	70/78	70/80	64/71	149/149	72/80	80/80	66/73	151/151

**ELECTRICAL INFORMATION
(UNITS PRODUCED ON OR AFTER JULY 30, 2012) cont.**

Table 12 - UNIT WIRE/FUSE OR HACR BREAKER SIZING DATA (cont.)

UNIT	NO M-V-PH-HZ	ELEC. HTR			NO C.O. or UNPWR C.O.																
		IFM TYPE	CRHEATER**A00	Nom (kW)	FLA	NO PE.				w/ PE. (pwrd fr/unit)				NO PE.				w/ PWRD C.O.			
						MCA	MAX FUSE or HACR BRKR	FLA	LRA	MCA	MAX FUSE or HACR BRKR	FLA	LRA	MCA	MAX FUSE or HACR BRKR	FLA	LRA	MCA	MAX FUSE or HACR BRKR	FLA	LRA
50TC**05	460-3-60	STD	NONE	-	-	12	15	11	52	13	15	12	53	14	15	14	54	15	20	15	55
			106A	6.0	7.2	13	15	11	52	14	15	12	53	15	15	14	54	17	20	15	55
			108A	11.5	13.8	21	25	19	52	22	25	20	53	24	25	21	54	25	25	23	55
			109A	14.0	16.8	25	25	22	52	26	30	23	53	27	30	25	54	29	30	26	55
			108A+108A	23.0	27.7	38	40	35	52	40	40	36	53	41	45	37	54	42	45	39	55
		MED	NONE	-	-	12	15	11	52	13	15	12	53	14	15	14	54	15	20	15	55
			106A	6.0	7.2	13	15	11	52	14	15	12	53	15	15	14	54	17	20	15	55
			108A	11.5	13.8	21	25	19	52	22	25	20	53	24	25	21	54	25	25	23	55
			109A	14.0	16.8	25	25	22	52	26	30	23	53	27	30	25	54	29	30	26	55
			108A+108A	23.0	27.7	38	40	35	52	40	40	36	53	41	45	37	54	42	45	39	55
HIGH	NONE	-	-	12	15	12	71	13	15	13	72	15	20	14	73	16	20	16	74		
	106A	6.0	7.2	14	15	12	71	15	15	13	72	16	20	15	73	18	20	16	74		
	108A	11.5	13.8	22	25	20	71	23	25	21	72	25	25	22	73	26	30	23	74		
	109A	14.0	16.8	26	30	23	71	27	30	24	72	28	30	26	73	30	30	27	74		
	108A+108A	23.0	27.7	39	40	36	71	41	45	37	72	42	45	38	73	43	45	39	74		
575-3-60	STD	-	-	9	15	9	42	11	15	11	44	11	15	11	44	13	15	13	46		
	MED	-	-	9	15	9	42	11	15	11	44	11	15	11	44	13	15	13	46		
	HIGH	-	-	9	15	9	46	11	15	11	48	11	15	10	48	13	15	13	50		

ELECTRICAL INFORMATION (UNITS PRODUCED ON OR AFTER JULY 30, 2012) cont.

Table 12 - UNIT WIRE/FUSE OR HACR BREAKER SIZING DATA (cont.)

UNIT	NO M. V-PH-HZ	ELEC. HTR				NO C.O. or UNPWR C.O.														
		CRHEATER***A00	Nom (kW)	FLA	MCA	NO PE.			w/ P.E. (pwrdr fr/unit)			NO PE.			w/ PWRD C.O.					
						MAX FUSE or HACR BRKR	FLA	LRA	MCA	MAX FUSE or HACR BRKR	FLA	LRA	MCA	MAX FUSE or HACR BRKR	FLA	LRA	MCA	MAX FUSE or HACR BRKR	FLA	LRA
50TC**06	208/230-1-60	NONE	-	-	40	60	37	150	42	60	40	152	44	60	43	155	46	60	45	157
		102A	4.9/6.5	23.5/27.1	40/40	60/60	37/37	150/150	42/43	60/60	40/40	152/152	44/46	60/60	43/43	155/155	46/49	60/60	45/45	157/157
		103B	6.5/8.7	31.4/36.3	48/52	60/60	42/47	150/150	48/54	60/60	44/50	152/152	52/58	60/60	47/53	155/155	54/60	60/60	49/55	157/157
		102A+102A	9.8/13.0	46.9/54.2	65/74	70/80	60/68	150/150	68/77	70/80	62/70	152/152	71/80	80/80	65/73	155/155	74/83	80/90	67/76	157/157
		103B+103B	13.1/17.4	62.8/72.5	85/97	90/100	78/89	150/150	87/100	90/100	80/91	152/152	91/103	100/110	89/95	155/155	93/106	100/110	86/97	157/157
		104B+104B	15.8/21.0	75.8/87.5	101/116	110/125	93/106	150/150	104/118	110/125	95/108	152/152	107/122	110/125	98/112	155/155	110/124	110/125	101/114	157/157
		NONE	-	-	42	60	40	175	44	60	42	177	47	60	45	180	48	60	48	182
		102A	4.9/6.5	23.5/27.1	42/43	60/60	40/40	175/175	44/45	60/60	42/42	177/177	47/49	60/60	45/45	180/180	48/51	60/60	48/48	182/182
		103B	6.5/8.7	31.4/36.3	48/55	60/60	44/50	175/175	51/57	60/60	46/52	177/177	54/61	60/70	50/55	180/180	57/63	60/70	52/58	182/182
		102A+102A	9.8/13.0	46.9/54.2	68/77	70/80	62/70	175/175	70/79	70/80	64/73	177/177	74/83	80/90	68/76	180/180	76/85	80/90	70/78	182/182
103B+103B	13.1/17.4	62.8/72.5	88/100	90/100	80/91	175/175	90/102	90/110	82/94	177/177	94/106	100/110	86/97	180/180	96/108	100/110	88/99	182/182		
104B+104B	15.8/21.0	75.8/87.5	104/119	110/125	95/109	175/175	106/121	110/125	97/111	177/177	110/125	110/125	101/114	180/180	112/127	125/150	103/116	182/182		
208/230-3-60	208/230-3-60	NONE	-	-	27	40	26	133	29	40	28	135	31	45	31	138	33	45	33	140
		102A	4.9/6.5	13.6/15.6	27/27	40/40	26/26	133/133	29/29	40/40	28/28	135/135	31/32	45/45	31/31	138/138	33/35	45/45	33/33	140/140
		104B	7.9/10.5	21.9/25.3	34/39	40/40	31/35	133/133	37/41	40/45	33/37	135/135	40/45	45/45	37/41	138/138	43/47	45/50	39/43	140/140
		105A	12.0/16.0	33.4/38.5	49/55	50/60	44/50	133/133	51/57	60/60	47/52	135/135	55/61	60/70	50/56	138/138	57/63	60/70	52/58	140/140
		104B+104B	15.8/21.0	43.8/50.5	62/70	70/70	56/64	133/133	64/72	70/80	59/66	135/135	68/76	70/80	62/70	138/138	70/78	70/80	64/72	140/140
		104B+105A	19.9/26.5	55.2/63.8	76/87	80/90	69/79	133/133	78/89	80/90	72/82	135/135	82/93	90/100	75/85	138/138	84/95	90/100	77/87	140/140
		NONE	-	-	28/28	40/40	28/27	171	30/30	45/45	30/30	173	33/33	45/45	33/33	176	35/35	50/50	35/35	178
		102A	4.9/6.5	13.6/15.6	28/28	40/40	28/27	171/171	30/31	45/45	30/30	173/173	33/34	45/45	33/33	176/176	35/37	50/50	35/35	178/178
		104B	7.9/10.5	21.9/25.3	36/40	40/40	33/37	171/171	39/43	45/45	35/39	173/173	42/46	45/50	39/42	176/176	45/49	50/50	41/45	178/178
		105A	12.0/16.0	33.4/38.5	51/57	60/60	46/52	171/171	53/59	60/60	49/54	173/173	57/63	60/70	52/58	176/176	59/65	60/70	54/60	178/178
104B+104B	15.8/21.0	43.8/50.5	64/72	70/80	58/66	171/171	66/74	70/80	60/68	173/173	70/78	70/80	64/71	176/176	72/80	80/80	66/73	178/178		
104B+105A	19.9/26.5	55.2/63.8	78/89	80/90	71/81	171/171	80/91	90/100	74/83	173/173	84/95	90/100	77/87	176/176	86/97	90/100	79/89	178/178		
HIGH	208/230-3-60	NONE	-	-	30/30	45/40	29/29	186	32/32	45/45	32/31	188	35/35	191	37/36	50/50	37/37	193		
		102A	4.9/6.5	13.6/15.6	30/30	45/40	29/29	186/186	32/33	45/45	32/31	188/188	35/36	45/45	191/191	37/39	50/50	37/37	193/193	
		104B	7.9/10.5	21.9/25.3	38/42	45/45	35/39	186/186	41/45	45/45	37/41	188/188	44/48	45/50	191/191	47/51	50/60	43/46	193/193	
		105A	12.0/16.0	33.4/38.5	53/59	60/60	48/54	186/186	55/61	60/70	50/56	188/188	59/65	60/70	54/59	191/191	61/67	70/70	56/62	193/193
		104B+104B	15.8/21.0	43.8/50.5	66/74	70/80	60/68	186/186	68/76	70/80	62/70	188/188	72/80	80/80	66/73	191/191	74/82	80/90	68/75	193/193
104B+105A	19.9/26.5	55.2/63.8	80/91	80/100	73/83	186/186	82/93	90/100	75/85	188/188	86/97	90/100	79/88	191/191	88/99	90/100	81/91	193/193		

**ELECTRICAL INFORMATION
(UNITS PRODUCED ON OR AFTER JULY 30, 2012) cont.**

Table 12 - UNIT WIRE/FUSE OR HACR BREAKER SIZING DATA (cont.)

UNIT	NO M, V-PH-HZ	ELEC. HTR			NO C.O. or UNPWR C.O.										NO PE.										w/ PWRD C.O.									
		IFM TYPE	CRHEATER**A00	Nom (kW)	FLA	NO PE.			w/ PE. (pwrdr fr/unit)			NO PE.			w/ PWRD C.O.			NO PE.			w/ PWRD C.O.			NO PE.			w/ PWRD C.O.							
						MCA	MAX FUSE or HACR BRKR	FLA	DISC. SIZE	LRA	MCA	MAX FUSE or HACR BRKR	FLA	DISC. SIZE	LRA	MCA	MAX FUSE or HACR BRKR	FLA	DISC. SIZE	LRA	MCA	MAX FUSE or HACR BRKR	FLA	DISC. SIZE	LRA	MCA	MAX FUSE or HACR BRKR	FLA	DISC. SIZE	LRA				
50TC**06	460-3-60	STD	NONE	-	-	13	20	13	63	63	14	20	14	64	64	16	20	15	65	65	17	20	16	66	66	17	20	16	66	66				
			106A	6.0	7.2	13	20	13	63	63	14	20	14	64	64	16	20	15	65	65	17	20	16	66	66	17	20	16	66	66				
			108A	11.5	13.8	21	25	19	63	63	22	25	20	25	64	64	24	25	21	65	65	25	25	23	66	66	25	25	23	66	66			
			109A	14.0	16.8	25	25	22	63	63	26	30	23	30	64	64	27	30	25	65	65	29	30	26	66	66	29	30	26	66	66			
			108A+108A	23.0	27.7	38	40	35	63	63	40	40	36	40	64	64	41	45	37	65	65	42	45	39	66	66	42	45	39	66	66			
			108A+108A	25.5	30.7	42	45	38	63	63	43	45	39	45	64	64	45	45	41	65	65	46	50	42	66	66	46	50	42	66	66			
			NONE	-	-	14	20	14	82	82	15	20	15	83	83	16	20	16	84	84	17	20	17	85	85	17	20	17	85	85				
			106A	6.0	7.2	14	20	14	82	82	15	20	15	83	83	16	20	16	84	84	17	20	17	85	85	17	20	17	85	85				
			108A	11.5	13.8	22	25	20	82	82	23	25	21	25	83	83	25	25	22	84	84	26	30	23	85	85	26	30	23	85	85			
			109A	14.0	16.8	26	30	23	82	82	27	30	24	30	83	83	28	30	26	84	84	30	30	27	85	85	30	30	27	85	85			
108A+108A	23.0	27.7	39	40	36	82	82	41	45	37	45	83	83	42	45	38	84	84	43	45	39	85	85	43	45	39	85	85						
108A+108A	25.5	30.7	43	45	39	82	82	44	45	40	45	83	83	46	50	42	84	84	47	50	43	85	85	47	50	43	85	85						
575-3-60	460-3-60	HIGH	NONE	-	-	15	20	15	90	90	16	20	16	91	91	17	20	17	92	92	18	20	18	93	93	18	20	18	93	93				
			106A	6.0	7.2	15	20	15	90	90	16	20	16	91	91	17	20	17	92	92	18	20	18	93	93	18	20	18	93	93				
			108A	11.5	13.8	23	25	21	90	90	24	25	22	25	91	91	26	30	23	92	92	27	30	24	93	93	27	30	24	93	93			
			109A	14.0	16.8	27	30	24	90	90	28	30	25	30	91	91	29	30	27	92	92	31	35	28	93	93	31	35	28	93	93			
			108A+108A	23.0	27.7	40	40	37	90	90	42	45	38	45	91	91	43	45	39	92	92	44	45	40	93	93	44	45	40	93	93			
			108A+108A	25.5	30.7	44	45	40	90	90	45	45	41	45	91	91	47	50	43	92	92	48	50	44	93	93	48	50	44	93	93			
			NONE	-	-	11	15	10	48	48	13	15	12	15	50	50	12	15	12	50	50	14	20	14	52	52	14	20	14	52	52			
			106A	6.0	7.2	15	20	15	48	48	16	20	16	20	49	49	17	20	17	50	50	18	20	18	51	51	18	20	18	51	51			
			108A	11.5	13.8	23	25	21	48	48	24	25	22	25	49	49	26	30	23	50	50	27	30	24	51	51	27	30	24	51	51			
			109A	14.0	16.8	27	30	24	48	48	28	30	25	30	49	49	29	30	27	50	50	31	35	28	51	51	31	35	28	51	51			
108A+108A	23.0	27.7	40	40	37	48	48	42	45	38	45	49	49	43	45	39	50	50	44	45	40	51	51	44	45	40	51	51						
108A+108A	25.5	30.7	44	45	40	48	48	45	45	41	45	49	49	47	50	43	50	50	48	50	44	51	51	48	50	44	51	51						
STD	460-3-60	NONE	-	-	11	15	10	48	48	13	15	12	50	50	12	15	12	50	50	14	20	14	52	52	14	20	14	52	52					
MED	460-3-60	NONE	-	-	10	15	10	52	52	12	15	12	54	54	12	15	12	54	54	14	15	14	56	56	14	15	14	56	56					
HIGH	460-3-60	NONE	-	-	11	15	11	63	63	13	15	13	65	65	13	15	13	65	65	15	20	15	67	67	15	20	15	67	67					

**ELECTRICAL INFORMATION
(UNITS PRODUCED ON OR AFTER JULY 30, 2012) cont.**

Table 12 - UNIT WIRE/FUSE OR HACR BREAKER SIZING DATA (cont.)

UNIT	NO M. V. Ph-HZ	ELEC. HTR				NO C.O. or UNPWR C.O.												w/ PWR C.O.											
		IFM TYPE	CRHEATER***A00	Nom (kW)	FLA	NO RE.				w/ P.E. (pwrd fr/unit)				NO PE.				w/ P.E. (pwrd fr/unit)											
						MCA	MAX FUSE or HACR BRKR	FLA	DISC. SIZE	LRA	MCA	MAX FUSE or HACR BRKR	FLA	DISC. SIZE	LRA	MCA	MAX FUSE or HACR BRKR	FLA	DISC. SIZE	LRA	MCA	MAX FUSE or HACR BRKR	FLA	DISC. SIZE	LRA				
50TCA08	460-3-60	STD	NONE	-	-	40/40	60/60	38/38	208	44/43	60/60	43/42	212	45/44	60/60	44/43	213	49/48	60/60	48/48	217	49/48	60/60	48/48	217/217				
			117A	7.8/10.4	21.7/25.0	40/40	60/60	38/38	208/208	44/43	60/60	43/42	212/212	45/44	60/60	44/43	213/213	49/49	60/60	48/48	217/217	49/49	60/60	48/48	217/217				
			110A	12.0/16.0	33.4/38.5	49/55	60/60	44/50	208/208	53/59	60/70	49/54	212/212	55/61	60/70	50/55	213/213	59/65	60/70	54/60	217/217	59/65	60/70	54/60	217/217				
			111A	18.6/24.8	51.7/59.7	72/81	80/90	65/74	208/208	76/86	80/90	70/79	212/212	78/87	80/90	71/80	213/213	82/92	80/90	75/84	217/217	82/92	90/100	75/84	217/217				
			112A	24.0/32.0	66.7/77.0	90/103	100/110	83/94	208/208	95/108	100/110	87/99	212/212	96/109	100/110	89/100	213/213	101/114	100/110	93/104	217/217	101/114	110/125	93/104	217/217				
			112A+117A	31.8/42.4	88.4/102.0	117/134	125/150	108/123	208/208	122/139	125/150	112/127	212/212	123/140	125/150	113/128	213/213	128/145	150/150	118/133	217/217	128/145	150/150	118/133	217/217				
			NONE	-	-	43/43	60/60	42/42	244	47/47	60/60	46/46	248	48/48	248	48/48	60/60	47/47	249	52/52	60/60	52/52	253	52/52	60/60	52/52	253/253		
			117A	7.8/10.4	21.7/25.0	43/43	60/60	42/42	244/244	47/47	60/60	46/46	248/248	48/48	248	48/48	60/60	47/47	249/249	52/52	60/60	52/52	253	52/52	60/60	52/52	253/253		
			110A	12.0/16.0	33.4/38.5	53/59	60/60	48/54	244/244	57/64	60/70	52/58	248/248	59/65	60/70	54/59	60/70	54/59	249/249	63/70	70/70	58/64	253/253	63/70	70/70	58/64	253/253		
			111A	18.6/24.8	51.7/59.7	76/85	80/90	69/78	244/244	80/90	80/90	73/83	248/248	82/91	90/100	82/91	90/100	82/91	249/249	86/96	90/100	79/88	253/253	86/96	90/100	79/88	253/253		
			112A	24.0/32.0	66.7/77.0	94/107	100/110	86/98	244/244	99/112	100/125	91/102	248/248	100/113	100/125	92/104	100/125	92/104	249/249	105/118	110/125	96/108	253/253	105/118	110/125	96/108	253/253		
			112A+117A	31.8/42.4	88.4/102.0	121/138	125/150	111/127	244/244	126/143	150/150	116/131	248/248	127/144	150/150	117/132	150/150	117/132	249/249	132/149	150/150	121/137	253/253	132/149	150/150	121/137	253/253		
50TCA08	460-3-60	STD	NONE	-	-	20	30	19	122	22	30	21	124	22	30	21	124	24	30	23	126	24	30	23	126				
			116A	13.9	16.7	24	30	22	122	27	30	24	124	27	30	25	124	29	30	27	126	29	30	27	126				
			113A	16.5	19.8	28	30	26	122	31	35	28	124	31	35	28	124	33	35	30	27	126	33	35	30	27			
			114A	27.8	33.4	45	45	41	122	48	50	43	124	48	50	44	124	50	50	46	46	46	126	50	50	46	46		
			115A	33.0	39.7	53	60	49	122	55	60	51	124	56	60	51	124	56	60	53	53	53	126	60	60	53	53		
			114A+116A	41.7	50.2	66	70	61	122	69	70	63	124	69	70	63	124	71	80	65	65	65	126	70	80	65	65		
			NONE	-	-	22	30	21	140	23	30	23	142	24	30	23	142	26	30	25	25	25	144	26	30	25	25		
			116A	13.9	16.7	27	30	24	140	29	30	26	142	29	30	27	142	32	35	29	29	29	144	32	35	29	29		
			113A	16.5	19.8	30	30	28	140	33	35	30	142	33	35	30	142	35	40	30	30	30	144	35	40	30	30		
			114A	27.8	33.4	47	50	43	140	50	50	45	142	50	50	46	142	52	60	46	46	46	144	52	60	46	46		
			115A	33.0	39.7	58	60	53	148	60	60	55	150	61	70	56	150	63	70	56	56	56	144	63	70	56	56		
			114A+116A	41.7	50.2	71	80	65	148	73	80	67	150	74	80	67	150	76	80	68	68	68	144	76	80	68	68		
575-3-60	STD	NONE	-	-	15	20	14	89	18	25	18	93	16	20	16	91	20	25	20	20	95	16	20	25	95				
		116A	13.9	16.7	29	30	27	148	32	35	29	150	32	35	29	150	34	35	31	31	152	34	35	31	152				
		113A	16.5	19.8	33	35	30	148	35	35	32	150	36	40	33	150	38	40	35	35	152	38	40	35	152				
		114A	27.8	33.4	50	50	46	148	52	60	48	150	53	60	48	150	55	60	48	48	48	152	55	60	48	48			
		115A	33.0	39.7	58	60	53	148	60	60	55	150	61	70	56	150	63	70	56	56	56	152	63	70	56	56			
		114A+116A	41.7	50.2	71	80	65	148	73	80	67	150	74	80	67	150	76	80	68	68	68	152	76	80	68	68			
		NONE	-	-	15	20	14	89	18	25	18	93	16	20	16	91	20	25	20	20	20	95	16	20	25	95			
		118A	17.0	20.4	28	30	25	89	33	35	30	93	30	30	27	91	35	35	30	30	30	95	35	35	30	30			
		119A	34.0	40.9	54	60	49	89	58	60	53	93	56	60	51	91	60	70	55	55	55	95	60	70	55	55			
		NONE	-	-	16	20	15	104	20	25	19	108	17	25	21	106	21	25	21	21	21	110	21	25	21	21			
		118A	17.0	20.4	29	30	27	104	34	35	31	108	32	35	29	106	36	40	33	33	33	110	36	40	33	33			
		119A	34.0	40.9	55	60	50	104	60	60	55	108	57	60	52	106	62	70	57	57	57	110	62	70	57	57			
575-3-60	HIGH	NONE	-	-	19	25	18	118	22	30	23	122	20	25	20	120	24	30	24	24	124	24	30	24	24				
		118A	17.0	20.4	33	35	30	118	38	40	34	122	35	35	32	120	40	40	36	36	124	40	40	36	36				
		119A	34.0	40.9	59	60	53	118	63	60	58	122	61	70	55	120	65	70	61	61	124	65	70	60	60				

**ELECTRICAL INFORMATION
(UNITS PRODUCED ON OR AFTER JULY 30, 2012) cont.**

Table 12 - UNIT WIRE/FUSE OR HACR BREAKER SIZING DATA (cont.)

UNIT	NO M. V.-Ph-HZ	ELEC. HTR				NO C.O. or UNPWR C.O.										NO P.E.										w/ PWRD C.O.			
		IFM TYPE	CRHEATER***A00	Nom (kW)	FLA	NO PE.				w/ P.E. (pwrd fr/unit)				NO PE.				w/ PWRD C.O.				w/ P.E. (pwrd fr/unit)							
						MCA	MAX FUSE or HACR BRKR	FLA	DISC. SIZE	MCA	MAX FUSE or HACR BRKR	FLA	DISC. SIZE	MCA	MAX FUSE or HACR BRKR	FLA	DISC. SIZE	MCA	MAX FUSE or HACR BRKR	FLA	DISC. SIZE	MCA	MAX FUSE or HACR BRKR	FLA	DISC. SIZE				
50TC-D08	208/230-3-60	STD	NONE	-	-	39/39	41/40	210	43/43	50/50	45/45	214	44/44	44/44	50/50	46/46	215	48/48	48/48	60/60	51/50	51/50	219	219/219					
			117A	7.8/10.4	21.7/25.0	39/39	41/40	210/210	43/43	50/50	45/45	214/214	44/44	44/44	50/50	46/46	215/215	48/48	48/48	60/60	60/60	51/50	51/50	219/219	219/219				
			110A	12.0/16.0	33.4/38.5	49/55	44/50	210/210	53/59	60/60	49/54	214/214	55/61	55/61	60/70	50/55	215/215	59/65	59/65	70/70	60/70	60/70	54/60	54/60	219/219	219/219			
			111A	18.6/24.8	51.7/59.7	72/81	65/74	210/210	76/86	80/90	70/79	214/214	78/87	78/87	80/90	71/80	215/215	82/92	82/92	90/100	90/100	90/100	75/84	75/84	219/219	219/219			
			112A	24.0/32.0	66.7/77.0	90/103	83/94	210/210	95/108	100/110	87/99	214/214	96/109	96/109	100/110	88/100	215/215	101/114	101/114	110/125	110/125	110/125	93/104	93/104	219/219	219/219			
			112A+117A	31.8/42.4	88.4/102.0	117/134	108/123	210/210	122/139	125/150	112/127	214/214	123/140	123/140	125/150	113/128	215/215	128/145	128/145	150/150	150/150	150/150	118/133	118/133	219/219	219/219			
	460-3-60	MED	NONE	-	-	42/42	44/44	246	46/46	50/50	49/49	250	47/47	47/47	60/60	50/50	251	51/51	51/51	60/60	60/60	54/54	255/255	255/255					
			117A	7.8/10.4	21.7/25.0	42/42	44/44	246/246	46/47	50/50	49/49	250/250	47/48	47/48	60/60	50/50	251/251	51/53	51/53	60/60	60/60	54/54	255/255	255/255					
			110A	12.0/16.0	33.4/38.5	53/59	48/54	246/246	57/64	60/70	52/58	250/250	59/65	59/65	60/70	54/59	251/251	63/70	63/70	70/70	70/70	58/64	255/255	255/255					
			111A	18.6/24.8	51.7/59.7	76/85	69/78	246/246	80/90	80/90	73/83	250/250	82/91	82/91	90/100	75/84	251/251	86/96	86/96	90/100	90/100	79/88	255/255	255/255					
			112A	24.0/32.0	66.7/77.0	94/107	86/98	246/246	99/112	100/125	91/102	250/250	100/113	100/113	100/125	92/104	251/251	105/118	105/118	110/125	110/125	96/108	255/255	255/255					
			112A+117A	31.8/42.4	88.4/102.0	121/138	111/127	246/246	126/143	150/150	116/131	250/250	127/144	127/144	150/150	117/132	251/251	132/149	132/149	150/150	150/150	121/137	255/255	255/255					
575-3-60	208/230-3-60	HIGH	NONE	-	-	48/47	50/49	262	51/51	60/60	55/54	266	52/52	52/52	60/60	56/55	267	56/55	56/55	60/60	60/59	271/271	271/271						
			117A	7.8/10.4	21.7/25.0	48/48	50/49	262/262	51/52	60/60	55/54	266/266	52/54	52/54	60/60	56/55	267/267	56/58	56/58	60/60	60/60	54/54	271/271	271/271					
			110A	12.0/16.0	33.4/38.5	59/64	54/59	262/262	64/69	70/70	58/63	266/266	65/70	65/70	70/70	60/64	267/267	70/75	70/75	70/80	70/80	64/68	271/271	271/271					
			111A	18.6/24.8	51.7/59.7	82/91	75/83	262/262	87/96	90/100	79/88	266/266	88/97	88/97	90/100	81/89	267/267	93/102	93/102	100/110	100/110	85/89	271/271	271/271					
			112A	24.0/32.0	66.7/77.0	101/113	92/103	262/262	106/117	110/125	97/108	266/266	107/119	107/119	110/125	98/109	267/267	112/123	112/123	125/125	125/125	102/113	271/271	271/271					
			112A+117A	31.8/42.4	88.4/102.0	128/144	117/132	262/262	133/149	150/150	122/136	266/266	134/150	134/150	150/150	123/137	267/267	139/155	139/155	150/175	150/175	127/142	271/271	271/271					
	460-3-60	STD	NONE	-	-	18	19	104	20	25	21	106	20	20	25	21	106	22	22	25	25	23	108	108					
			116A	13.9	16.7	24	22	104	27	30	24	106	27	27	30	25	106	29	29	30	30	27	108	108					
			113A	16.5	19.8	28	26	104	31	35	28	106	31	31	35	28	106	33	33	35	35	30	108	108					
			114A	27.8	33.4	45	41	104	48	50	43	106	48	48	50	44	106	50	50	50	50	46	108	108					
			115A	33.0	39.7	53	49	104	55	60	51	106	55	55	60	51	106	58	58	60	60	53	108	108					
			114A+116A	41.7	50.2	66	61	104	69	70	61	106	69	69	70	63	106	71	71	80	80	65	108	108					
575-3-60	MED	NONE	-	-	20	21	122	22	25	23	124	22	22	25	23	124	22	22	25	25	23	126	126						
		116A	13.9	16.7	27	24	122	29	30	26	124	29	29	30	26	124	32	32	35	35	29	126	126						
		113A	16.5	19.8	30	28	122	33	35	30	124	33	33	35	30	124	35	35	40	40	32	126	126						
		114A	27.8	33.4	47	43	122	50	50	45	124	50	50	50	46	124	52	52	60	60	48	126	126						
		115A	33.0	39.7	55	50	122	58	60	53	124	58	58	60	53	124	60	60	60	60	55	126	126						
		114A+116A	41.7	50.2	68	63	122	71	80	65	124	71	71	80	65	124	73	73	80	80	67	126	126						
575-3-60	HIGH	NONE	-	-	22	23	130	24	30	25	132	24	24	30	26	132	26	26	30	30	28	134	134						
		116A	13.9	16.7	29	27	130	32	35	29	132	32	32	35	29	132	34	34	35	35	31	134	134						
		113A	16.5	19.8	33	30	130	35	35	32	132	36	36	40	33	132	38	38	40	40	35	134	134						
		114A	27.8	33.4	50	46	130	52	60	48	132	53	53	60	48	132	55	55	60	60	50	134	134						
		115A	33.0	39.7	58	53	130	60	60	55	132	61	61	70	56	132	63	63	70	70	58	134	134						
		114A+116A	41.7	50.2	71	65	130	73	80	67	132	74	74	80	68	132	76	76	80	80	70	134	134						
575-3-60	STD	NONE	-	-	13	13	77	17	20	17	81	14	14	15	79	81	14	14	15	15	15	83	83						
		118A	17.0	20.4	28	25	77	33	35	30	81	31	31	35	27	79	35	35	35	35	32	83	83						
		119A	34.0	40.9	54	49	77	58	60	53	81	56	56	60	51	79	60	60	70	70	55	83	83						
		NONE	-	-	14	14	92	18	20	19	96	16	16	20	16	94	19	19	25	25	21	98	98						
		118A	17.0	20.4	29	27	92	34	35	31	96	32	32	35	29	94	36	36	40	40	33	98	98						
		119A	34.0	40.9	55	50	92	60	60	55	96	57	57	60	52	94	62	62	70	70	57	98	98						
575-3-60	HIGH	NONE	-	-	17	17	106	21	25	22	110	19	19	20	108	23	23	25	25	24	112	112							
		118A	17.0	20.4	33	30	106	38	40	34	110	35	35	40	32	108	40	40	40	40	36	112	112						
		119A	34.0	40.9	59	53	106	63	60	58	110	61	61	70	55	108	65	65	70	70	60	112	112						

ELECTRICAL INFORMATION (UNITS PRODUCED ON OR AFTER JULY 30, 2012) cont.

Table 12 - UNIT WIRE/FUSE OR HACR BREAKER SIZING DATA (cont.)

UNIT	NO M-V-PH-HZ	ELEC. HTR				NO C.O. or UNPWR C.O.																
		IFM TYPE	CRHEATER***A00	Nom (KW)	FLA	NO RE.				w/ P.E. (pwrd fr/unit)				NO PE.				w/ PWRD C.O.				
						MCA	MAX FUSE or BRKR	FLA	DISC. SIZE	LRA	MCA	MAX FUSE or BRKR	FLA	DISC. SIZE	LRA	MCA	MAX FUSE or BRKR	FLA	DISC. SIZE	LRA	MCA	MAX FUSE or BRKR
507C*A09	460-3-60	STD	NONE	-	-	46/45	60/60	43/43	239	239	243	48/47	60/60	49/49	50/50	60/60	49/49	244	54/54	80/80	53/53	248
			117A	7.8/10.4	21.7/25.0	46/45	60/60	43/43	239/239	239	243	48/47	60/60	49/49	50/50	60/60	49/49	244	54/54	80/80	53/53	248/248
			110A	12.0/16.0	33.4/38.5	49/55	60/60	44/50	239/239	239	243	48/47	60/60	49/49	50/50	60/60	49/49	244/244	54/54	80/80	53/53	248/248
			111A	18.6/24.8	51.7/59.7	72/81	80/90	65/74	239/239	239	243	70/79	80/90	76/86	78/87	80/90	71/80	244/244	82/92	90/100	75/84	248/248
			112A	24.0/32.0	66.7/77.0	90/103	90/110	83/94	239/239	239	243	87/99	100/110	95/108	96/109	100/110	88/100	244/244	101/114	110/125	93/104	248/248
			112A+117A	31.8/42.4	88.4/102.0	117/134	125/150	108/123	239/239	239	243	112/127	125/150	122/139	123/140	125/150	113/128	244/244	128/145	150/150	118/133	248/248
			NONE	-	-	47/47	60/60	45/45	260	260	264	50/49	60/60	51/51	52/52	60/60	51/51	265	56/56	80/80	55/55	269
			117A	7.8/10.4	21.7/25.0	47/47	60/60	45/45	260/260	260	264	50/49	60/60	51/51	52/52	60/60	51/51	265/265	56/56	80/80	55/55	269/269
			110A	12.0/16.0	33.4/38.5	51/57	60/60	46/52	260/260	260	264	51/56	60/70	56/62	57/63	60/80	52/58	265/265	62/68	80/80	56/62	269/269
			111A	18.6/24.8	51.7/59.7	74/83	80/90	67/76	260/260	260	264	72/81	80/90	78/88	80/89	80/90	73/82	265/265	84/94	90/100	77/86	269/269
			112A	24.0/32.0	66.7/77.0	92/105	100/110	85/96	260/260	260	264	89/101	100/110	97/110	98/111	100/125	90/102	265/265	103/116	110/125	95/106	269/269
			112A+117A	31.8/42.4	88.4/102.0	120/136	125/150	110/125	260/260	260	264	114/129	125/150	124/141	126/142	150/150	115/131	265/265	130/147	150/150	119/135	269/269
507C*A09	460-3-60	STD	NONE	-	-	23	30	22	117	117	119	24	30	25	25	30	24	119	27	40	26	121
			116A	13.9	16.7	24	30	22	117	117	119	24	30	25	25	30	24	119	27	40	26	121
			113A	16.5	19.8	28	30	26	117	117	119	24	30	25	28	30	25	119	29	40	27	121
			114A	27.8	33.4	45	45	41	117	117	119	43	50	48	48	50	44	119	50	50	46	121
			115A	33.0	39.7	53	60	49	117	117	119	51	60	55	56	60	51	119	58	60	53	121
			114A+116A	41.7	50.2	66	70	61	117	117	119	63	70	69	69	70	63	119	71	80	65	121
			NONE	-	-	24	30	23	127	127	129	25	30	26	26	30	25	129	28	40	27	131
			116A	13.9	16.7	26	30	23	127	127	129	25	30	28	28	30	25	129	28	40	28	131
			113A	16.5	19.8	29	30	27	127	127	129	29	35	32	32	40	29	129	34	40	31	131
			114A	27.8	33.4	46	50	42	127	127	129	44	50	49	49	50	45	129	51	60	47	131
			115A	33.0	39.7	54	60	50	127	127	129	52	60	57	57	60	52	129	59	60	54	131
			114A+116A	41.7	50.2	67	70	62	127	127	129	64	70	70	70	70	64	129	72	80	66	131
575-3-60	460-3-60	HIGH	NONE	-	-	26	30	25	142	142	144	27	40	28	28	40	144	30	40	29	146	
			116A	13.9	16.7	28	30	25	142	142	144	27	40	28	28	40	144	33	40	30	146	
			113A	16.5	19.8	32	35	29	142	142	144	31	40	34	35	40	31	144	37	40	33	146
			114A	27.8	33.4	49	50	45	142	142	144	47	60	52	52	60	44	144	54	60	47	146
			115A	33.0	39.7	57	60	52	142	142	144	54	60	59	59	60	54	144	62	70	56	146
			114A+116A	41.7	50.2	70	70	64	142	142	144	66	80	72	73	80	66	144	75	80	68	146
			NONE	-	-	19	30	17	91	91	95	22	30	22	22	30	19	93	24	30	24	97
			118A	17.0	20.4	28	30	25	91	91	95	30	35	30	30	30	27	93	35	35	32	97
			119A	34.0	40.9	54	60	49	91	91	95	58	60	53	56	60	51	93	60	70	55	97
			NONE	-	-	19	30	18	95	95	99	23	30	23	21	30	20	97	24	30	24	101
			118A	17.0	20.4	28	30	26	95	95	99	33	35	30	30	35	28	97	35	35	32	101
			119A	34.0	40.9	54	60	49	95	95	99	59	60	54	56	60	51	97	61	70	56	101
575-3-60	HIGH	NONE	-	-	20	30	19	106	24	30	23	21	30	20	108	25	30	25	30	25	112	
		118A	17.0	20.4	29	30	27	106	34	35	31	110	32	35	29	108	36	40	33	112		
		119A	34.0	40.9	55	60	50	106	60	60	55	110	57	60	52	108	62	70	57	112		

**ELECTRICAL INFORMATION
(UNITS PRODUCED ON OR AFTER JULY 30, 2012) cont.**

Table 12 - UNIT WIRE/FUSE OR HACR BREAKER SIZING DATA (cont.)

UNIT	NO M-V-PH-HZ	ELEC. HTR				NO C.O. or UNPWR C.O.																
		CRHEATER***A00	Nom (KW)	FLA	NO RE.			w/ P.E. (pwrd fr/unit)			NO PE.			w/ PWRD C.O.								
					MCA	MAX FUSE or BRKR	DISC. SIZE FLA LRA	MCA	MAX FUSE or BRKR	DISC. SIZE FLA LRA	MCA	MAX FUSE or BRKR	DISC. SIZE FLA LRA	MCA	MAX FUSE or BRKR	DISC. SIZE FLA LRA						
50TC+D09	STD	NONE	-	-	40/40	50/50	42/42	225	44/44	50/50	46/46	46/46	229	45/45	50/50	47/47	230	49/49	60/60	52/51	234	
		117A	7.8/10.4	21.7/25.0	40/40	50/50	42/42	225/225	44/44	50/50	46/46	46/46	229/229	45/45	50/50	47/47	230/230	49/49	60/60	52/51	234/234	
		110A	12.0/16.0	33.4/38.5	49/55	60/60	44/50	225/225	53/59	60/60	49/54	229/229	55/61	60/70	50/55	60/70	230/230	59/65	60/70	54/60	234/234	
		111A	18.6/24.8	51.7/59.7	72/81	80/90	65/74	225/225	76/86	80/90	70/79	229/229	78/87	80/90	71/80	80/90	230/230	82/92	82/92	90/100	75/84	234/234
		112A	24.0/32.0	66.7/77.0	90/103	100/110	83/94	225/225	95/108	100/110	87/99	229/229	96/109	100/110	88/100	100/110	230/230	101/114	110/125	93/104	93/104	234/234
		112A+117A	31.8/42.4	88.4/102.0	117/134	125/150	108/123	225/225	122/139	125/150	112/127	229/229	123/140	125/150	113/128	123/140	230/230	128/145	118/133	150/150	118/133	234/234
		NONE	-	-	42/42	50/50	44/44	246	46/46	60/50	47/47	47/47	250	47/47	60/60	49/49	251	51/51	54/53	60/60	54/53	255
		117A	7.8/10.4	21.7/25.0	42/42	50/50	44/44	246/246	46/46	60/50	48/48	48/48	250/250	47/47	60/60	49/49	251/251	51/51	54/53	60/60	54/53	255/255
		110A	12.0/16.0	33.4/38.5	51/57	60/60	46/52	246/246	56/62	60/70	51/56	250/250	57/63	60/70	52/58	60/70	251/251	62/68	60/66	70/70	56/62	255/255
		111A	18.6/24.8	51.7/59.7	74/83	80/90	67/76	246/246	78/88	80/90	72/81	250/250	80/89	80/90	73/82	80/90	251/251	84/94	84/94	90/100	77/86	255/255
		112A	24.0/32.0	66.7/77.0	92/105	100/110	85/96	246/246	97/110	100/110	89/101	250/250	98/111	100/125	90/102	100/125	251/251	103/116	103/116	110/125	95/106	255/255
		112A+117A	31.8/42.4	88.4/102.0	120/136	125/150	110/125	246/246	124/141	125/150	114/129	250/250	126/142	150/150	115/131	150/150	251/251	130/147	130/147	150/150	119/135	255/255
460-3-60	STD	NONE	-	-	19	20	118	20	25	21	120	21	25	21	25	120	23	23	25	24	122	
		116A	13.9	16.7	24	30	22	118	27	30	24	120	27	30	25	120	29	29	30	27	122	
		113A	16.5	19.8	28	30	26	118	31	35	28	120	31	35	28	120	33	33	35	30	122	
		114A	27.8	33.4	45	45	41	118	48	50	43	120	48	50	44	120	50	50	50	46	122	
		115A	33.0	39.7	53	60	49	118	55	60	51	120	56	60	51	120	58	58	60	53	122	
		114A+116A	41.7	50.2	66	70	61	118	69	70	63	120	69	70	63	120	71	71	80	65	122	
		NONE	-	-	20	25	20	128	21	25	22	130	22	25	23	130	24	24	25	25	25	132
		116A	13.9	16.7	26	30	23	128	28	30	25	130	28	30	26	130	31	31	35	28	28	132
		113A	16.5	19.8	29	30	27	128	32	35	29	130	32	35	29	130	34	34	35	31	31	132
		114A	27.8	33.4	46	44	42	128	49	50	44	130	49	50	45	130	51	51	60	47	47	132
		115A	33.0	39.7	54	60	50	128	57	60	52	130	57	60	52	130	59	59	60	54	54	132
		114A+116A	41.7	50.2	67	70	62	128	70	70	64	130	70	70	64	130	72	72	80	66	66	132
575-3-60	STD	NONE	-	-	21	25	143	23	25	24	145	24	25	24	145	25	25	25	22	22	91	
		116A	13.9	16.7	28	30	25	143	30	30	27	145	31	35	28	145	33	33	35	30	147	
		113A	16.5	19.8	32	35	29	143	34	35	31	145	35	35	31	145	37	37	40	33	147	
		114A	27.8	33.4	49	50	45	143	51	60	47	145	52	60	47	145	54	54	60	47	147	
		115A	33.0	39.7	57	60	52	143	59	60	54	145	59	60	54	145	62	62	70	56	147	
		114A+116A	41.7	50.2	70	70	64	143	72	80	66	145	73	80	66	145	75	75	80	68	147	
		NONE	-	-	16	20	16	85	19	25	20	89	17	20	18	87	21	21	25	22	22	91
		118A	17.0	20.4	28	30	25	85	33	35	30	93	30	30	27	87	35	35	35	32	32	91
		119A	34.0	40.9	54	60	49	85	58	60	53	93	56	60	51	87	61	61	70	55	55	91
		NONE	-	-	16	20	16	89	20	25	20	93	18	20	18	91	21	21	25	22	22	95
		118A	17.0	20.4	28	30	26	89	33	35	30	93	31	35	28	91	35	35	35	32	32	95
		119A	34.0	40.9	54	60	49	89	59	60	54	93	56	60	51	91	61	61	70	56	56	95
HIGH	NONE	-	-	17	20	17	100	21	25	21	104	18	20	19	102	22	22	25	23	23	106	
	118A	17.0	20.4	29	30	27	100	34	35	31	104	32	35	29	102	36	36	40	33	33	106	
	119A	34.0	40.9	55	60	50	100	60	60	55	104	57	60	52	102	62	62	70	57	57	106	

ELECTRICAL INFORMATION (UNITS PRODUCED ON OR AFTER JULY 30, 2012) cont.

Table 12 - UNIT WIRE/FUSE OR HACR BREAKER SIZING DATA (cont.)

UNIT	IFM TYPE	ELEC. HTR				NO C.O. or UNPWR C.O.										w/ PWRD C.O.				
		CRHEATER***A00	Nom (kW)	FLA	NO PE.				w/ P.E. (pwrd fr/unit)				NO PE.				w/ P.E. (pwrd fr/unit)			
					MCA	MAX FUSE or HACR BRKR	FLA	DISC. SIZE	MCA	MAX FUSE or HACR BRKR	FLA	DISC. SIZE	MCA	MAX FUSE or HACR BRKR	FLA	DISC. SIZE	MCA	MAX FUSE or HACR BRKR	FLA	DISC. SIZE
50TC*14	STD	NONE	-	-	64/64	376	66/66	80/80	69/69	380	67/67	80/80	70/70	381	71/71	80/80	74/74	385		
		117A	7.8/10.4	21.7/25.0	64/64	376/376	66/66	80/80	69/69	380/380	67/67	80/80	70/70	381/381	71/71	80/80	74/74	385/385		
		110A	12.0/16.0	33.4/38.5	62/62	376/376	66/66	80/80	69/69	380/380	67/67	80/80	70/70	381/381	71/71	80/80	74/74	385/385		
		112A	24.0/32.0	66.7/77.0	94/107	376/376	99/112	100/125	91/102	380/380	100/113	100/125	92/104	381/381	105/118	110/125	96/108	385/385		
		112A+117A	31.8/42.4	88.4/102.0	121/138	376/376	126/143	150/150	116/131	380/380	127/144	150/150	117/132	381/381	132/149	150/150	121/137	385/385		
		112A+110A	37.6/50.0	104.2/120.3	141/131	376/376	146/136	150/150	134/152	380/380	147/137	150/150	135/153	381/381	152/142	175/150	139/158	385/385		
		NONE	-	-	64	390	68	80	71	394	69	80	72	395	73	80	77	399		
		117A	7.8/10.4	21.7/25.0	64/64	390/390	68/68	80/80	71/71	394/394	69/69	80/80	72/72	395/395	73/73	80/80	77/77	399/399		
		110A	12.0/16.0	33.4/38.5	64/64	390/390	68/68	80/80	71/71	394/394	69/69	80/80	72/72	395/395	73/73	80/80	77/77	399/399		
		112A	24.0/32.0	66.7/77.0	97/110	390/390	102/115	110/125	93/105	394/394	103/116	110/125	94/106	395/395	108/121	110/125	99/111	399/399		
460-3-60	MED	112A+117A	31.8/42.4	88.4/102.0	124/141	390/390	129/146	150/150	118/134	394/394	130/147	150/150	119/135	395/395	135/152	150/175	124/139	399/399		
		112A+110A	37.6/50.0	104.2/120.3	144/134	390/390	149/139	150/150	136/155	394/394	150/140	150/150	138/156	395/395	155/145	175/175	142/160	399/399		
		NONE	-	-	67/66	392	71/70	80/80	75/74	396	72/71	80/80	76/75	397	76/75	80/79	401			
		117A	7.8/10.4	21.7/25.0	67/66	392/392	71/70	80/80	75/74	396/396	72/71	80/80	76/75	397/397	76/75	80/79	401/401			
		110A	12.0/16.0	33.4/38.5	67/66	392/392	71/70	80/80	75/74	396/396	72/71	80/80	76/75	397/397	76/75	80/79	401/401			
		112A	24.0/32.0	66.7/77.0	101/113	392/392	106/117	110/125	97/108	396/396	107/119	110/125	98/109	397/397	112/123	125/125	102/113	401/401		
		112A+117A	31.8/42.4	88.4/102.0	128/144	392/392	133/149	150/150	122/136	396/396	134/150	150/150	123/137	397/397	139/155	150/175	127/142	401/401		
		112A+110A	37.6/50.0	104.2/120.3	148/137	392/392	152/141	175/175	140/157	396/396	154/143	175/175	141/158	397/397	158/147	175/175	145/163	401/401		
		NONE	-	-	31	189	33	40	34	191	33	40	34	191	35	40	36	193		
		116A	13.9	16.7	16.7	189	33	40	34	191	33	40	34	191	35	40	36	193		
575-3-60	STD	113A	16.5	19.8	31	189	33	40	191	33	40	34	191	35	40	36	193			
		115A	33.0	39.7	55	189	58	60	53	191	58	60	53	191	60	60	55	193		
		114A+116A	41.7	50.2	68	189	71	80	65	191	71	80	65	191	73	80	67	193		
		115A+113A	50.0	60.1	66	189	68	70	74	191	69	80	76	191	71	80	79	193		
		NONE	-	-	32	196	34	40	35	198	34	40	36	198	36	40	38	200		
		116A	13.9	16.7	32	196	34	40	35	198	34	40	36	198	36	40	38	200		
		113A	16.5	19.8	32	196	34	40	35	198	34	40	36	198	36	40	38	200		
		115A	33.0	39.7	57	196	59	60	54	198	59	60	54	198	62	70	56	200		
		114A+116A	41.7	50.2	70	196	72	80	66	198	73	80	66	198	75	80	68	200		
		115A+113A	50.0	60.1	67	196	69	70	77	198	70	80	78	198	72	80	80	200		
575-3-60	HIGH	NONE	-	-	33	197	35	40	199	35	45	37	199	37	45	39	201			
		116A	13.9	16.7	33	197	35	40	199	35	45	37	199	37	45	39	201			
		113A	16.5	19.8	33	197	35	40	199	35	45	37	199	37	45	39	201			
		115A	33.0	39.7	58	197	60	60	55	199	61	70	56	199	63	70	58	201		
		114A+116A	41.7	50.2	71	197	73	80	67	199	74	80	68	199	76	80	70	201		
		115A+113A	50.0	60.1	69	197	71	80	79	199	71	80	79	199	74	80	81	201		
		NONE	-	-	23	142	27	30	28	146	24	30	25	144	28	30	30	148		
		118A	17.0	20.4	29	142	34	35	31	146	32	35	29	144	36	40	33	148		
		119A	34.0	40.9	55	142	60	60	55	146	57	60	52	144	62	70	57	148		
		118A+119A	51.0	61.3	65	142	70	70	78	146	67	70	76	144	72	80	80	148		
575-3-60	MED	NONE	-	-	23	142	27	30	146	24	30	25	144	28	30	30	148			
		118A	17.0	20.4	29	142	34	35	31	146	32	35	29	144	36	40	33	148		
		119A	34.0	40.9	55	142	60	60	55	146	57	60	52	144	62	70	57	148		
		118A+119A	51.0	61.3	65	142	70	70	78	146	67	70	76	144	72	80	80	148		
		NONE	-	-	23	142	27	30	28	146	24	30	25	144	28	30	30	148		
		118A	17.0	20.4	29	142	34	35	31	146	32	35	29	144	36	40	33	148		
		119A	34.0	40.9	55	142	60	60	55	146	57	60	52	144	62	70	57	148		
		118A+119A	51.0	61.3	65	142	70	70	78	146	67	70	76	144	72	80	80	148		
		NONE	-	-	26	156	29	30	31	160	27	30	29	158	31	35	33	162		
		118A	17.0	20.4	33	156	38	40	34	160	35	35	32	158	40	40	36	162		
119A	34.0	40.9	59	156	63	70	58	160	61	70	55	158	65	70	60	162				
118A+119A	51.0	61.3	69	156	74	80	81	160	71	80	79	158	76	80	83	162				

**ELECTRICAL INFORMATION
(UNITS PRODUCED ON OR AFTER JULY 30, 2012) cont.**

Table 12 - UNIT WIRE/FUSE OR HACR BREAKER SIZING DATA (cont.)

UNIT	NO M, V-Ph-HZ	ELEC. HTR				NO C.O. or UNPWR C.O.																	
		IFM TYPE	CRHEATER**A00	Nom (kW)	FLA	NO PE.				w/ PE. (pwrdr fr/unit)				NO PE.				w/ PWRD C.O.					
						MCA	MAX FUSE or HACR BRKR	FLA	LRA	MCA	MAX FUSE or HACR BRKR	FLA	LRA	MCA	MAX FUSE or HACR BRKR	FLA	LRA	MCA	MAX FUSE or HACR BRKR	FLA	LRA		
50TC*D16	575-3-60	STD	NONE	-	-	27	30	28	184	31	40	32	188	29	35	30	186	32	186	32	40	34	190
			293A	16.5	15.9	27	30	28	184	31	40	32	188	29	35	30	186	32	186	32	40	34	190
			296A	33.5	32.2	44	45	40	184	49	50	45	188	46	50	42	186	51	60	47	60	47	190
			290A+296A	43.5	41.8	56	60	51	184	61	70	56	188	58	60	53	186	63	70	58	70	58	190
			293A+296A	50.0	48.1	52	60	59	184	57	60	63	188	54	60	60	186	59	60	65	60	65	190
			296A+296A	67.0	64.4	68	80	77	184	73	80	82	188	70	80	79	186	75	80	84	80	84	190
			NONE	-	-	27	30	28	184	31	40	32	188	29	35	30	186	32	186	32	40	34	190
			293A	16.5	15.9	27	30	28	184	31	40	32	188	29	35	30	186	32	186	32	40	34	190
			296A	33.5	32.2	44	45	40	184	49	50	45	188	46	50	42	186	51	60	47	60	47	190
			290A+296A	43.5	41.8	56	60	51	184	61	70	56	188	58	60	53	186	63	70	58	70	58	190
293A+296A	50.0	48.1	52	60	59	184	57	60	63	188	54	60	60	186	59	60	65	60	65	190			
296A+296A	67.0	64.4	68	80	77	184	73	80	82	188	70	80	79	186	75	80	84	80	84	190			
HIGH	575-3-60	NONE	-	-	33	40	35	196	37	45	39	200	35	40	37	198	39	45	39	45	41	202	
		293A	16.5	15.9	33	40	35	196	37	45	39	200	35	40	37	198	39	45	39	45	41	202	
		296A	33.5	32.2	52	60	47	196	57	60	52	200	54	60	49	198	59	60	54	60	54	202	
		290A+296A	43.5	41.8	64	70	58	196	69	70	63	200	66	70	60	198	71	80	65	80	65	202	
		293A+296A	50.0	48.1	60	70	66	196	65	70	70	200	62	70	68	198	67	70	72	70	72	202	
296A+296A	67.0	64.4	76	80	84	196	81	90	89	200	78	80	86	198	83	90	91	90	91	202			

ELECTRICAL INFORMATION (UNITS PRODUCED ON OR AFTER JULY 30, 2012) cont.

Table 13 - UNIT WIRE/FUSE OR HACR BREAKER SIZING DATA WITH 2 SPEED INDOOR FAN MOTOR (cont.)

UNIT	NO. M. V.-Ph. Hz	ELEC. HTR				NO C.O. or UNPWR C.O.				NO PWR C.O.														
		CRHEATER***A00	Nom (kW)	FLA	MCA	MAX FUSE or HACR BRKR	DISC. SIZE FLA LRA	MCA	MCA	MAX FUSE or HACR BRKR	DISC. SIZE FLA LRA	MCA	MCA	MAX FUSE or HACR BRKR	DISC. SIZE FLA LRA									
50TC*D14	460-3-60	NONE	-	-	62/61	80/80	65/64	357	66/65	80/80	69/68	361	67/66	80/80	70/69	362	71/70	80/80	75/74	366				
					7.8/10.4	21.7/25.0	62/61	80/80	65/64	357/357	66/65	80/80	69/68	361/361	67/66	80/80	70/69	362/362	71/70	80/80	75/74	366/366		
					117A	7.8/10.4	21.7/25.0	62/61	80/80	65/64	357/357	66/65	80/80	69/68	361/361	67/66	80/80	70/69	362/362	71/70	80/80	75/74	366/366	
					110A	12.0/16.0	33.4/38.5	62/61	80/80	65/64	357/357	66/65	80/80	69/68	361/361	67/66	80/80	70/69	362/362	71/70	80/80	75/74	366/366	
					112A	24.0/32.0	66.7/77.0	95/106	100/110	87/98	357/357	99/111	100/125	100/125	91/102	361/361	101/112	110/125	92/103	362/362	105/117	110/125	96/107	366/366
					112A+117A	31.8/42.4	88.4/102.0	122/138	125/150	112/126	357/357	126/142	150/150	150/150	116/131	361/361	128/144	150/150	117/132	362/362	132/148	150/150	121/136	366/366
					112A+110A	37.6/50.0	104.2/120.3	141/131	150/150	134/152	357/357	146/135	150/150	150/150	134/152	361/361	147/137	150/150	135/153	362/362	152/141	175/150	140/157	366/366
					NONE	-	-	64/63	80/80	67/66	381	68/67	80/80	72/70	385	69/68	80/80	73/72	386	73/72	80/80	77/76	390	
					117A	7.8/10.4	21.7/25.0	64/63	80/80	67/66	381/381	68/67	80/80	72/70	385/385	69/68	80/80	73/72	386/386	73/72	80/80	77/76	390/390	
					110A	12.0/16.0	33.4/38.5	64/63	80/80	67/66	381/381	68/67	80/80	72/70	385/385	69/68	80/80	73/72	386/386	73/72	80/80	77/76	390/390	
50TC*D14	208/230-3-60	NONE	-	-	67/66	80/80	70/69	392	71/70	80/80	75/74	396	72/71	80/80	76/75	397	76/75	90/90	80/79	401				
					7.8/10.4	21.7/25.0	67/66	80/80	70/69	392/392	71/70	80/80	75/74	396/396	72/71	80/80	76/75	397/397	76/75	90/90	80/79	401/401		
					110A	12.0/16.0	33.4/38.5	67/66	80/80	70/69	392/392	71/70	80/80	75/74	396/396	72/71	80/80	76/75	397/397	76/75	90/90	80/79	401/401	
					112A	24.0/32.0	66.7/77.0	101/113	110/125	92/103	392/392	106/117	110/125	97/108	396/396	107/119	110/125	98/109	397/397	112/123	125/125	102/113	401/401	
					112A+117A	31.8/42.4	88.4/102.0	128/144	150/150	117/132	392/392	133/149	150/150	122/136	396/396	134/150	150/150	123/137	397/397	139/155	150/175	127/142	401/401	
					112A+110A	37.6/50.0	104.2/120.3	148/137	150/150	135/153	392/392	152/141	175/175	140/157	396/396	154/143	175/175	141/158	397/397	158/147	175/175	142/138	401/401	
					NONE	-	-	30	40	31	180	32	40	33	182	33	40	34	182	34	40	36	184	
					116A	13.9	16.7	30	40	31	180	32	40	33	182	33	40	34	182	34	40	36	184	
					113A	16.5	19.8	30	40	31	180	32	40	33	182	33	40	34	182	35	40	36	184	
					115A	33.0	39.7	55	60	50	180	57	60	60	182	58	60	60	182	60	60	60	184	
50TC*D14	460-3-60	NONE	-	-	68	70	62	80	72	80	64	182	71	80	66	182	73	80	67	184				
					114A+116A	41.7	50.2	68	70	62	80	72	80	64	182	71	80	66	182	73	80	67	184	
					115A+113A	50.0	60.1	65	70	73	180	68	70	66	182	68	70	66	182	70	68	184		
					NONE	-	-	31	40	33	192	33	40	35	194	34	40	35	194	35	40	37	196	
					116A	13.9	16.7	31	40	33	192	33	40	35	194	34	40	35	194	35	40	37	196	
					113A	16.5	19.8	31	40	33	192	34	40	35	194	34	40	35	194	36	40	37	196	
					115A	33.0	39.7	56	60	51	192	60	60	53	194	59	60	60	194	61	70	56	196	
					114A+116A	41.7	50.2	69	70	63	192	72	80	65	194	72	80	80	66	194	74	80	68	196
					115A+113A	50.0	60.1	67	80	75	192	69	80	77	199	69	80	80	77	194	72	80	68	196
					575-3-60	575-3-60	NONE	-	-	33	40	34	197	35	40	36	199	35	40	37	199	37	45	39
116A	13.9	16.7	33	40						34	197	35	40	36	199	35	40	37	199	37	45	39	201	
113A	16.5	19.8	33	40						34	197	35	40	36	199	36	40	37	199	38	45	39	201	
115A	33.0	39.7	58	60						53	197	60	60	55	199	61	70	56	199	63	70	58	201	
114A+116A	41.7	50.2	71	80						65	197	73	80	67	199	74	80	68	199	76	80	70	201	
115A+113A	50.0	60.1	69	80						76	197	71	80	79	199	71	80	79	199	74	80	81	201	
NONE	-	-	24	30						25	142	28	30	30	146	26	30	30	27	144	30	35	148	
118A	17.0	20.4	32	35						29	142	36	40	33	146	34	35	35	31	144	38	40	35	148
119A	34.0	40.9	57	60						52	142	62	70	57	146	59	60	60	54	144	64	70	59	148
118A+119A	51.0	61.3	67	80						76	142	72	80	80	146	74	80	80	78	144	74	80	82	148
575-3-60	575-3-60	NONE	-	-	24	30	25	142	28	30	30	146	26	30	30	27	144	30	35	148				
					118A	17.0	20.4	32	35	29	142	36	40	33	146	34	35	31	144	38	40	35	148	
					119A	34.0	40.9	57	60	52	142	62	70	57	146	59	60	60	54	144	64	70	59	148
					118A+119A	51.0	61.3	67	80	76	142	72	80	80	146	74	80	80	78	144	74	80	82	148
					NONE	-	-	24	30	25	142	28	30	30	146	26	30	30	27	144	30	35	148	
					118A	17.0	20.4	32	35	29	142	36	40	33	146	34	35	31	144	38	40	35	148	
					119A	34.0	40.9	57	60	52	142	62	70	57	146	59	60	60	54	144	64	70	59	148
					118A+119A	51.0	61.3	67	80	76	142	72	80	80	146	74	80	80	78	144	74	80	82	148
					NONE	-	-	26	30	27	156	30	35	32	160	28	30	29	158	32	35	34	162	
					118A	17.0	20.4	34	35	31	156	38	40	33	160	36	40	33	158	41	45	37	162	
119A	34.0	40.9	59	60	54	156	64	70	59	160	61	70	60	56	158	66	70	60	162					
118A+119A	51.0	61.3	70	80	78	156	74	80	82	160	72	80	80	80	158	76	80	84	162					

ELECTRICAL INFORMATION (UNITS PRODUCED ON OR AFTER JULY 30, 2012) cont.

Table 13 - UNIT WIRE/FUSE OR HACR BREAKER SIZING DATA WITH 2 SPEED INDOOR FAN MOTOR (cont.)

UNIT	NO M.V.-Ph-HZ	ELEC. HTR				NO C.O. or UNPWR C.O.						NO PE.						w/ PWRD C.O.					
		IFM TYPE	CRHEATER**A00	Nom (kW)	FLA	MCA	MAX FUSE or HACR BRKR	DISC. SIZE		MCA	MAX FUSE or HACR BRKR	DISC. SIZE		MCA	MAX FUSE or HACR BRKR	DISC. SIZE		MCA	MAX FUSE or HACR BRKR	DISC. SIZE			
								FLA	LRA			FLA	LRA			FLA	LRA			FLA	LRA		
501C'D16		NONE				29	35	30	184	32	40	34	188	30	35	32	186	34	40	36	190		
		293A	16.5	15.9	32.2	29	35	30	184	32	40	34	188	30	35	32	186	34	40	36	190		
		296A	33.5	32.2	41.8	46	50	42	184	51	60	47	188	48	50	44	186	53	60	49	190		
		290A+296A	43.5	41.8	58	58	60	53	184	63	70	58	188	60	60	55	186	65	70	60	190		
		299A+296A	50.0	48.1	64.4	54	60	60	184	59	60	65	188	56	60	62	186	61	70	67	190		
		296A+296A	67.0	64.4	70	70	80	79	184	75	80	84	188	73	80	81	186	77	80	86	190		
575-3-60		NONE				29	35	30	184	32	40	34	188	30	35	32	186	34	40	36	190		
		293A	16.5	15.9	32.2	29	35	30	184	32	40	34	188	30	35	32	186	34	40	36	190		
		296A	33.5	32.2	41.8	46	50	42	184	51	60	47	188	48	50	44	186	53	60	49	190		
		290A+296A	43.5	41.8	58	58	60	53	184	63	70	58	188	60	60	55	186	65	70	60	190		
		299A+296A	50.0	48.1	64.4	54	60	60	184	59	60	65	188	56	60	62	186	61	70	67	190		
		296A+296A	67.0	64.4	70	70	80	79	184	75	80	84	188	73	80	81	186	77	80	86	190		
HIGH		NONE				33	40	35	196	37	45	39	200	35	40	37	198	39	45	41	202		
		293A	16.5	15.9	32.2	33	40	35	196	37	45	39	200	35	40	37	198	39	45	41	202		
		296A	33.5	32.2	41.8	52	60	47	196	57	60	52	200	54	60	49	198	59	60	54	202		
		290A+296A	43.5	41.8	64.4	64	70	58	196	69	70	63	200	66	70	60	198	71	80	65	202		
		299A+296A	50.0	48.1	64.4	60	70	66	196	65	70	70	200	62	70	68	198	67	70	72	202		
		296A+296A	67.0	64.4	76	76	80	84	196	81	90	89	200	78	80	86	198	83	90	91	202		

Example: Supply voltage is 230-3-60

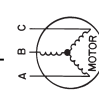

AB = 224 V
BC = 231 V
AC = 226 V

$$\text{Average Voltage} = \frac{(224 + 231 + 226)}{3} = \frac{681}{3} = 227$$

Determine maximum deviation from average voltage.

(AB) $227 - 224 = 3$ V

(BC) $231 - 227 = 4$ V

(AC) $227 - 226 = 1$ V

Maximum deviation is 4 v.

Determine percent of voltage imbalance.

$$\% \text{ Voltage Imbalance} = 100 \times \frac{4}{227} = 1.76\%$$

This amount of phase imbalance is satisfactory as it is below the maximum allowable 2%.

IMPORTANT: If the supply voltage phase imbalance is more than 2%, contact your local electric utility company immediately.



- Circuit breaker
- Convenience outlet
- Disconnect
- Full load amps
- Indoor fan motor
- Locked rotor amps
- Minimum circuit amps
- MAX FUSE or HACR Breaker
- Power exhaust
- Powered convenient outlet
- Unpowered convenient outlet

LEGEND:

- BRKR
- CO
- DISC
- FLA
- IFM
- LRA
- MCA
- MOCAP
- PE
- PWRD CO
- UNPWR CO

NOTES:

1. In compliance with NEC requirements for multimotor and combination load equipment (refer to NEC Articles 430 and 440), the overcurrent protective device for the unit shall be fuse or HACR breaker. Canadian units may be fuse or circuit breaker.

Unbalanced 3-Phase Supply Voltage

Never operate a motor where a phase imbalance in supply voltage is greater than 2%. Use the following formula to determine the percentage of voltage imbalance.

$$\% \text{ Voltage Imbalance} = 100 \times \frac{\text{max voltage deviation from average voltage}}{\text{average voltage}}$$

ELECTRICAL DATA FOR UNITS PRODUCED PRIOR TO JULY 30, 2012

NOTE: Check the serial number of unit to verify production date.

To confirm the date of manufacture, locate the unit nameplate and check the first four digits of the Serial Number. If the number listed in the first 4 digits of the Serial Number is 3111 or lower, the unit was produced prior to July 30, 2012.

Position:	1	2	3	4	5	6	7	8	9	10
Example:	3	1	1	2	U	1	2	3	4	5

Week of manufacture (fiscal calendar)			Sequence number
Year of manufacture ("12" = 2012)		Manufacturing location	

C12562A

ELECTRICAL INFORMATION
(UNITS PRODUCED PRIOR TO JULY 30, 2012)

Table 14 – 50TC*A04 1-STAGE COOLING WITH 1-SPEED INDOOR FAN MOTOR

3 TONS

V-Ph-Hz	VOLTAGE RANGE		COMP (ea)		OFM (ea)		IFM		
	MIN	MAX	RLA	LRA	WATTS	FLA	TYPE	EFF at Full Load	FLA
208-1-60	187	253	16.6	79	325	1.5	STD	70%	4.9
							MED	70%	4.9
230-1-60	187	253	16.6	79	325	1.5	STD	70%	4.9
							MED	70%	4.9
208-3-60	187	253	10.4	73	325	1.5	STD	70%	4.9
							MED	70%	4.9
							HIGH	80%	5.2
230-3-60	187	253	10.4	73	325	1.5	STD	70%	4.9
							MED	70%	4.9
							HIGH	80%	5.2
460-3-60	414	506	5.8	38	325	0.8	STD	70%	2.1
							MED	70%	2.1
							HIGH	80%	2.6
575-3-60	518	633	3.8	37	325	0.6	STD	71%	1.9
							MED	71%	1.9
							HIGH	80%	2.0

Table 14 (cont.) - 50TC*A05 1-STAGE COOLING WITH 1-SPEED INDOOR FAN MOTOR

4 TONS

V-Ph-Hz	VOLTAGE RANGE		COMP (ea)		OFM (ea)		IFM		
	MIN	MAX	RLA	LRA	WATTS	FLA	TYPE	EFF at Full Load	FLA
208-1-60	187	253	21.8	117	325	1.5	STD	70%	4.9
							MED	78%	7.0
230-1-60	187	253	21.8	117	325	1.5	STD	70%	4.9
							MED	78%	7.0
208-3-60	187	253	13.7	83	325	1.5	STD	70%	4.9
							MED	70%	4.9
							HIGH	80%	5.2
230-3-60	187	253	13.7	83	325	1.5	STD	70%	4.9
							MED	70%	4.9
							HIGH	80%	5.2
460-3-60	414	506	6.2	41	325	0.8	STD	70%	2.1
							MED	70%	2.1
							HIGH	80%	2.6
575-3-60	518	633	4.8	37	325	0.6	STD	71%	1.9
							MED	71%	2.1
							HIGH	80%	2.0

Table 14 (cont.) - 50TC*A06 1-STAGE COOLING WITH 1-SPEED INDOOR FAN MOTOR

5 TONS

V-Ph-Hz	VOLTAGE RANGE		COMP (ea)		OFM (ea)		IFM		
	MIN	MAX	RLA	LRA	WATTS	FLA	TYPE	EFF at Full Load	FLA
208-1-60	187	253	26.2	134	325	1.5	STD	70%	4.9
							MED	78%	7.0
230-1-60	187	253	26.2	134	325	1.5	STD	70%	4.9
							MED	78%	7.0
208-3-60	187	253	15.6	110	325	1.5	STD	70%	4.9
							MED	80%	5.2
							HIGH	81%	7.5
230-3-60	187	253	15.6	110	325	1.5	STD	70%	4.9
							MED	80%	5.2
							HIGH	81%	7.5
460-3-60	414	506	7.7	52	325	0.8	STD	70%	2.1
							MED	80%	2.6
							HIGH	81%	3.4
575-3-60	518	633	5.8	39	325	0.6	STD	71%	1.9
							MED	81%	2.0
							HIGH	81%	2.8

ELECTRICAL INFORMATION
(UNITS PRODUCED PRIOR TO JULY 30, 2012) cont.

Table 14 (cont.) - 50TC*A07 1-STAGE COOLING WITH 1-SPEED INDOOR FAN MOTOR

6 TONS

V-Ph-Hz	VOLTAGE RANGE		COMP (ea)		OFM (ea)		IFM		
	MIN	MAX	RLA	LRA	WATTS	FLA	TYPE	EFF at Full Load	FLA
208-3-60	187	253	19.0	123	325	1.5	STD	80%	5.2
							MED	81%	7.5
							HIGH	81%	7.5
230-3-60	187	253	19.0	123	325	1.5	STD	80%	5.2
							MED	81%	7.5
							HIGH	81%	7.5
460-3-60	414	506	9.7	62	325	0.8	STD	80%	2.6
							MED	81%	3.4
							HIGH	81%	4.4
575-3-60	518	633	7.4	50	325	0.6	STD	80%	2.0
							MED	81%	2.8
							HIGH	81%	2.8

Table 14 (cont.) - 50TC*A08 1-STAGE COOLING WITH 1-SPEED INDOOR FAN MOTOR

7.5 TONS

V-Ph-Hz	VOLTAGE RANGE		COMP (ea)		OFM (ea)		IFM		
	MIN	MAX	RLA	LRA	WATTS	FLA	TYPE	EFF at Full Load	FLA
208-3-60	187	253	25.0	164	325	1.5	STD	80%	5.2
							MED	81%	7.5
							HIGH	81%	15.0
230-3-60	187	253	25.0	164	325	1.5	STD	80%	5.2
							MED	81%	7.5
							HIGH	81%	15.0
460-3-60	414	506	12.2	100	325	0.8	STD	80%	2.6
							MED	81%	3.4
							HIGH	81%	7.4
575-3-60	518	633	9.0	78	325	0.6	STD	80%	2.4
							MED	81%	2.8
							HIGH	81%	5.6

Table 14 (cont.) - 50TC*D08 2-STAGE COOLING WITH 1-SPEED INDOOR FAN MOTOR

7.5 TONS

V-Ph-Hz	VOLTAGE RANGE		COMP (Cir 1)		COMP (Cir 2)		OFM (ea)		IFM		
	MIN	MAX	RLA	LRA	RLA	LRA	WATTS	FLA	TYPE	EFF at Full Load	FLA
208-3-60	187	253	13.6	83	13.6	83	325	1.5	STD	80%	5.2
									MED	81%	7.5
									HIGH	81%	15.0
230-3-60	187	253	13.6	83	13.6	83	325	1.5	STD	80%	5.2
									MED	81%	7.5
									HIGH	81%	15.0
460-3-60	414	506	6.1	41	6.1	41	325	0.8	STD	80%	2.6
									MED	81%	3.4
									HIGH	81%	7.4
575-3-60	518	633	4.2	33	4.2	33	325	0.6	STD	80%	2.4
									MED	81%	2.8
									HIGH	81%	5.6

ELECTRICAL INFORMATION
(UNITS PRODUCED PRIOR TO JULY 30, 2012) cont.

Table 14 (cont.) - 50TC*D08 2-STAGE COOLING WITH 2-SPEED INDOOR FAN MOTOR

7.5 TONS

V-Ph-Hz	VOLTAGE RANGE		COMP 1		COMP 2		OFM (ea)		IFM		
	MIN	MAX	RLA	LRA	RLA	LRA	WATTS	FLA	TYPE	EFF at Full Load	FLA
208-3-60	187	253	13.6	83	13.6	83	325	1.5	STD	84%	5.8
							325	1.5	MED	85%	8.6
							325	1.5	HIGH	84%	13.6
230-3-60	187	253	13.6	83	13.6	83	325	1.5	STD	84%	5.6
							325	1.5	MED	85%	7.8
							325	1.5	HIGH	84%	12.7
460-3-60	414	506	6.1	41	6.1	41	325	0.8	STD	79%	2.9
							325	0.8	MED	85%	3.8
							325	0.8	HIGH	84%	6.4
575-3-60	518	633	4.2	33	4.2	33	325	0.6	STD	81%	2.8
							325	0.6	MED	84%	4.5
							325	0.6	HIGH	83%	6.2

Table 14 (cont.) - 50TC*A09 1-STAGE COOLING WITH 1-SPEED INDOOR FAN MOTOR

8.5 TONS

V-Ph-Hz	VOLTAGE RANGE		COMP (ea)		OFM (ea)		IFM		
	MIN	MAX	RLA	LRA	WATTS	FLA	TYPE	EFF at Full Load	FLA
208-3-60	187	253	29.5	195	325	1.5	STD	80%	5.2
							MED	80%	5.2
							HIGH	80%	10.0
230-3-60	187	253	29.5	195	325	1.5	STD	80%	5.2
							MED	80%	5.2
							HIGH	80%	10.0
460-3-60	414	506	14.7	95	325	0.8	STD	80%	2.6
							MED	80%	2.6
							HIGH	80%	4.4
575-3-60	518	633	12.2	80	325	0.6	STD	80%	2.4
							MED	80%	2.0
							HIGH	81%	2.8

Table 14 (cont.) - 50TC*D09 2-STAGE COOLING WITH 1-SPEED INDOOR FAN MOTOR

8.5 TONS

V-Ph-Hz	VOLTAGE RANGE		COMP (Cir 1)		COMP (Cir 2)		OFM (ea)		IFM		
	MIN	MAX	RLA	LRA	RLA	LRA	WATTS	FLA	TYPE	EFF at Full Load	FLA
208-3-60	187	253	14.5	98	13.7	83	325	1.5	STD	80%	5.2
									MED	80%	5.2
									HIGH	80%	10.0
230-3-60	187	253	14.5	98	13.7	83	325	1.5	STD	80%	5.2
									MED	80%	5.2
									HIGH	80%	10.0
460-3-60	414	506	6.3	55	6.2	41	325	0.8	STD	80%	2.6
									MED	80%	2.6
									HIGH	80%	4.4
575-3-60	518	633	6.0	41	4.8	33	325	0.6	STD	80%	2.4
									MED	80%	2.0
									HIGH	81%	2.8

ELECTRICAL INFORMATION
(UNITS PRODUCED PRIOR TO JULY 30, 2012) cont.

Table 14 (cont.) - 50TC*D09 2-STAGE COOLING WITH 2-SPEED INDOOR FAN MOTOR

8.5 TONS

V-Ph-Hz	VOLTAGE RANGE		COMP 1		COMP 2		OFM (ea)		IFM		
	MIN	MAX	RLA	LRA	RLA	LRA	WATTS	FLA	TYPE	EFF at Full Load	FLA
208-3-60	187	253	14.5	98	13.7	83	325	1.5	STD	84%	5.8
							325	1.5	MED	77%	7.1
							325	1.5	HIGH	82%	10.8
230-3-60	187	253	14.5	98	13.7	83	325	1.5	STD	84%	5.6
							325	1.5	MED	77%	6.8
							325	1.5	HIGH	82%	9.8
460-3-60	414	506	6.3	55	6.2	41	325	0.8	STD	79%	2.9
							325	0.8	MED	77%	3.8
							325	0.8	HIGH	82%	4.9
575-3-60	518	633	6.0	41	4.8	33	325	0.6	STD	81%	2.8
							325	0.6	MED	80%	3.5
							325	0.6	HIGH	84%	4.5

Table 14 (cont.) - 50TC*A12 1-STAGE COOLING WITH 1-SPEED INDOOR FAN MOTOR

10 TONS

V-Ph-Hz	VOLTAGE RANGE		COMP (ea)		OFM (ea)		IFM		
	MIN	MAX	RLA	LRA	WATTS	FLA	TYPE	EFF at Full Load	FLA
208-3-60	187	253	30.1	225	325	1.5	STD	80%	5.2
							MED	81%	10.0
							HIGH	81%	15.0
230-3-60	187	253	30.1	225	325	1.5	STD	80%	5.2
							MED	81%	10.0
							HIGH	81%	15.0
460-3-60	414	506	16.7	114	325	0.8	STD	80%	2.6
							MED	81%	4.4
							HIGH	81%	7.4
575-3-60	518	633	12.2	80	325	0.6	STD	80%	2.0
							MED	81%	2.8
							HIGH	81%	5.6

Table 14 (cont.) - 50TC*D12 2-STAGE COOLING WITH 1-SPEED INDOOR FAN MOTOR

10 TONS

V-Ph-Hz	VOLTAGE RANGE		COMP (Cir 1)		COMP (Cir 2)		OFM (ea)		IFM		
	MIN	MAX	RLA	LRA	RLA	LRA	WATTS	FLA	TYPE	EFF at Full Load	FLA
208-3-60	187	253	15.6	110	15.9	110	325	1.5	STD	80%	5.2
									MED	81%	10.0
									HIGH	81%	15.0
230-3-60	187	253	15.6	110	15.9	110	325	1.5	STD	80%	5.2
									MED	81%	10.0
									HIGH	81%	15.0
460-3-60	414	506	7.7	52	7.7	52	325	0.8	STD	80%	2.6
									MED	81%	4.4
									HIGH	81%	7.4
575-3-60	518	633	5.8	39	5.7	39	325	0.6	STD	80%	2.0
									MED	81%	2.8
									HIGH	81%	5.6

ELECTRICAL INFORMATION
(UNITS PRODUCED PRIOR TO JULY 30, 2012) cont.

Table 14 (cont.) - 50TC*D12 2-STAGE COOLING WITH 2-SPEED INDOOR FAN MOTOR

10 TONS

V-Ph-Hz	VOLTAGE RANGE		COMP 1		COMP 2		OFM (ea)		IFM		
	MIN	MAX	RLA	LRA	RLA	LRA	WATTS	FLA	TYPE	EFF at Full Load	FLA
208-3-60	187	253	15.6	110	15.9	110	325	1.5	STD	77%	7.1
							325	1.5	MED	82%	10.8
							325	1.5	HIGH	84%	13.6
230-3-60	187	253	15.6	110	15.9	110	325	1.5	STD	77%	6.8
							325	1.5	MED	82%	9.8
							325	1.5	HIGH	84%	12.7
460-3-60	414	506	7.7	52	7.7	52	325	0.8	STD	77%	3.8
							325	0.8	MED	82%	4.9
							325	0.8	HIGH	84%	6.4
575-3-60	518	633	5.8	39	5.7	39	325	0.6	STD	80%	3.5
							325	0.6	MED	84%	4.5
							325	0.6	HIGH	83%	6.2

Table 14 (cont.) - 50TC*D14 2-STAGE COOLING WITH 1-SPEED INDOOR FAN MOTOR

12.5 TONS

V-Ph-Hz	VOLTAGE RANGE		COMP (Cir 1)		COMP (Cir 2)		OFM (ea)		IFM		
	MIN	MAX	RLA	LRA	RLA	LRA	WATTS	FLA	TYPE	EFF at Full Load	FLA
208-3-60	187	253	19.0	123	22.4	149	1288	6.2	STD	81%	7.5
									MED	81%	10.0
									HIGH	81%	15.0
230-3-60	187	253	19.0	123	22.4	149	1288	6.2	STD	81%	7.5
									MED	81%	10.0
									HIGH	81%	15.0
460-3-60	414	506	9.7	62	10.6	75	1288	3.1	STD	81%	3.4
									MED	81%	4.4
									HIGH	81%	7.4
575-3-60	518	633	7.4	50	7.7	54	1288	2.5	STD	81%	2.8
									MED	81%	2.8
									HIGH	81%	5.6

Table 14 (cont.) - 50TC*D14 2-STAGE COOLING WITH 2-SPEED INDOOR FAN MOTOR

12.5 TONS

V-Ph-Hz	VOLTAGE RANGE		COMP 1		COMP 2		OFM (ea)		IFM		
	MIN	MAX	RLA	LRA	RLA	LRA	WATTS	FLA	TYPE	EFF at Full Load	FLA
208-3-60	187	253	19.0	123	22.4	149	1070	6.2	STD	85%	8.6
							1070	6.2	MED	82%	10.8
							1070	6.2	HIGH	84%	13.6
230-3-60	187	253	19.0	123	22.4	149	1070	6.2	STD	85%	7.8
							1070	6.2	MED	82%	9.8
							1070	6.2	HIGH	84%	12.7
460-3-60	414	506	9.7	62	10.6	75	1070	3.1	STD	85%	3.8
							1070	3.1	MED	82%	4.9
							1070	3.1	HIGH	84%	6.4
575-3-60	518	633	7.4	50	7.7	54	1070	2.5	STD	84%	4.5
							1070	2.5	MED	84%	4.5
							1070	2.5	HIGH	83%	6.2

ELECTRICAL INFORMATION
(UNITS PRODUCED PRIOR TO JULY 30, 2012) cont.

Table 14 (cont.) - 50TC*D16 2-STAGE COOLING WITH 1-SPEED INDOOR FAN MOTOR

15 TONS

V-Ph-Hz	VOLTAGE RANGE		COMP (Cir 1)		COMP (Cir 2)		OFM (ea)		IFM		
	MIN	MAX	RLA	LRA	RLA	LRA	WATTS	FLA	TYPE	EFF at Full Load	FLA
208-3-60	187	253	25.0	164	25.0	164	1288	1.5	STD	81%	7.5
									MED	81%	10.0
									HIGH	89.5%	20.4
230-3-60	187	253	25.0	164	25.0	164	1288	1.5	STD	81%	7.5
									MED	81%	10.0
									HIGH	89.5%	20.4
460-3-60	414	506	12.2	100	12.8	100	1288	0.8	STD	81%	3.4
									MED	81%	4.4
									HIGH	89.5%	10.2
575-3-60	518	633	9.8	78	9.6	78	1288	0.6	STD	81%	2.8
									MED	81%	2.8
									HIGH	89.5%	9.0

Table 14 (cont.) - 50TC*D16 2-STAGE COOLING WITH 2-SPEED INDOOR FAN MOTOR

15 TONS

V-Ph-Hz	VOLTAGE RANGE		COMP 1		COMP 2		OFM (ea)		IFM		
	MIN	MAX	RLA	LRA	RLA	LRA	WATTS	FLA	TYPE	EFF at Full Load	FLA
208-3-60	187	253	25.0	164	25.0	164	280	1.5	STD	85%	8.6
							280	1.5	MED	82%	10.8
							280	1.5	HIGH	90%	20.4
230-3-60	187	253	25.0	164	25.0	164	280	1.5	STD	85%	7.8
							280	1.5	MED	82%	9.8
							280	1.5	HIGH	90%	20.4
460-3-60	414	506	12.2	100	12.8	100	280	0.8	STD	85%	3.8
							280	0.8	MED	82%	4.9
							280	0.8	HIGH	90%	10.2
575-3-60	518	633	9.8	78	9.6	78	280	0.6	STD	84%	4.5
							280	0.6	MED	84%	4.5
							280	0.6	HIGH	94%	9.0

ELECTRICAL INFORMATION

(UNITS PRODUCED PRIOR TO JULY 30, 2012) cont.

Table 15 – 50TC*A04

ELECTRIC HEAT - ELECTRICAL DATA 1-STAGE COOLING 1-SPEED INDOOR FAN MOTOR

NOM. V-PH-Hz.	IFM TYPE	ELECTRIC HEATER PART NUMBER CRHEATERXXXXXX	NOM PWR (kW)	APP PWR (kW)	SINGLE POINT KIT PART NUMBER CRSINGLEXXXXXX			
					NO C.O. or UNPWRD C.O.		w/PWRD C.O.	
					NO P.E.	w/P.E. (pwr fr/unit)	NO P.E.	w/P.E. (pwr fr/unit)
208/ 230-1-60	STD	101A00	4.4	3.3/4.0	-	-	-	-
		102A00	6.5	4.9/6.0	-	-	-	-
		103B00	8.7	6.5/8.0	037A00	037A00	037A00	037A00
		104B00	10.5	7.9/9.6	040A00	040A00	040A00	040A00
		102A00,102A00	13	9.8/11.9	040A00	040A00	040A00	040A00
	MED	101A00	4.4	3.3/4.0	-	-	-	-
		102A00	6.5	4.9/6.0	-	-	-	-
		103B00	8.7	6.5/8.0	037A00	037A00	037A00	037A00
		104B00	10.5	7.9/9.6	040A00	040A00	040A00	040A00
		102A00,102A00	13	9.8/11.9	040A00	040A00	040A00	040A00
208/ 230-3-60	STD	101A00	4.4	3.3/4.0	-	-	-	-
		102A00	6.5	4.9/6.0	-	-	-	-
		103B00	8.7	6.5/8.0	-	-	-	-
		104B00	10.5	7.9/9.6	-	-	-	-
		105A00	16	12.0/14.7	037A00	037A00	038A00	038A00
	MED	101A00	4.4	3.3/4.0	-	-	-	-
		102A00	6.5	4.9/6.0	-	-	-	-
		103B00	8.7	6.5/8.0	-	-	-	-
		104B00	10.5	7.9/9.6	-	-	-	-
		105A00	16	12.0/14.7	037A00	037A00	038A00	038A00
	HIGH	101A00	4.4	3.3/4.0	-	-	-	-
		102A00	6.5	4.9/6.0	-	-	-	-
		103B00	8.7	6.5/8.0	-	-	-	-
		104B00	10.5	7.9/9.6	-	-	-	-
		105A00	16	12.0/14.7	037A00	037A00	038A00	038A00
460-3-60	STD	106A00	6	5.5	-	-	-	-
		107A00	8.8	8.1	-	-	-	-
		108A00	11.5	10.6	-	-	-	-
		109A00	14	12.9	-	-	-	-
	MED	106A00	6	5.5	-	-	-	-
		107A00	8.8	8.1	-	-	-	-
		108A00	11.5	10.6	-	-	-	-
		109A00	14	12.9	-	-	-	-
	HIGH	106A00	6	5.5	-	-	-	-
		107A00	8.8	8.1	-	-	-	-
		108A00	11.5	10.6	-	-	-	-
		109A00	14	12.9	-	-	-	-

LEGEND

- APP PWR - 208 / 230V / 460V / 575V
- C.O. - Convenience outlet
- FLA - Full load amps
- IFM - Indoor fan motor
- NOM PWR - 240V / 480V / 600V
- P.E. - Power exhaust
- PWRD - Powered convenience outlet
- UNPWRD - Unpowered convenience outlet

ELECTRICAL INFORMATION

(UNITS PRODUCED PRIOR TO JULY 30, 2012) cont.

Table 15 (cont.) - 50TC*A05

ELECTRIC HEAT - ELECTRICAL DATA 1-STAGE COOLING 1-SPEED INDOOR FAN MOTOR

NOM. V-PH-Hz.	IFM TYPE	ELECTRIC HEATER PART NUMBER CRHEATERXXXXXX	NOM PWR (kW)	APP PWR (kW)	SINGLE POINT KIT PART NUMBER CRSINGLEXXXXXX			
					NO C.O. or UNPWRD C.O.		w/PWRD C.O.	
					NO P.E.	w/P.E. (pwrd fr/unit)	NO P.E.	w/P.E. (pwrd fr/unit)
208/ 230-1-60	STD	101A00	4.4	3.3/4.0	-	-	-	-
		103B00	8.7	6.5/8.0	037A00	037A00	037A00	037A00
		102A00,102A00	13	9.8/11.9	040A00	040A00	040A00	040A00
		103B00,103B00	17.4	13.1/16.0	040A00	040A00	040A00	040A00
		104B00,104B00	21	15.8/19.3	040A00	040A00	040A00	040A00
	MED	101A00	4.4	3.3/4.0	-	-	-	-
		103B00	8.7	6.5/8.0	037A00	037A00	037A00	037A00
		102A00,102A00	13	9.8/11.9	040A00	040A00	040A00	040A00
		103B00,103B00	17.4	13.1/16.0	040A00	040A00	040A00	040A00
		104B00,104B00	21	15.8/19.3	040A00	040A00	040A00	040A00
208/ 230-3-60	STD	102A00	6.5	4.9/6.0	-	-	-	-
		103B00	8.7	6.5/8.0	-	-	-	-
		105A00	16	12.0/14.7	037A00	037A00	038A00	038A00
		104B00,104B00	21	15.8/19.3	038A00	038A00	038A00	038A00
	MED	102A00	6.5	4.9/6.0	-	-	-	-
		103B00	8.7	6.5/8.0	-	-	-	-
		105A00	16	12.0/14.7	037A00	037A00	038A00	038A00
		104B00,104B00	21	15.8/19.3	038A00	038A00	038A00	038A00
	HIGH	102A00	6.5	4.9/6.0	-	-	-	-
		103B00	8.7	6.5/8.0	-	-	-	-
		105A00	16	12.0/14.7	037A00	037A00	038A00	038A00
		104B00,104B00	21	15.8/19.3	038A00	038A00	038A00	038A00
460-3-60	STD	106A00	6	5.5	-	-	-	-
		108A00	11.5	10.6	-	-	-	-
		109A00	14	12.9	-	-	-	-
		108A00,108A00	23	21.1	037A00	037A00	037A00	037A00
	MED	106A00	6	5.5	-	-	-	-
		108A00	11.5	10.6	-	-	-	-
		109A00	14	12.9	-	-	-	-
		108A00,108A00	23	21.1	037A00	037A00	037A00	037A00
	HIGH	106A00	6	5.5	-	-	-	-
		108A00	11.5	10.6	-	-	-	-
		109A00	14	12.9	-	-	-	-
		108A00,108A00	23	21.1	037A00	037A00	037A00	037A00

LEGEND

- APP PWR - 208 / 230V / 460V / 575V
- C.O. - Convenience outlet
- FLA - Full load amps
- IFM - Indoor fan motor
- NOM PWR - 240V / 480V / 600V
- P.E. - Power exhaust
- PWRD - Powered convenience outlet
- UNPWRD - Unpowered convenience outlet

ELECTRICAL INFORMATION

(UNITS PRODUCED PRIOR TO JULY 30, 2012) cont.

Table 15 (cont.) - 50TC*A06

ELECTRIC HEAT - ELECTRICAL DATA 1-STAGE COOLING 1-SPEED INDOOR FAN MOTOR

NOM. V-PH-Hz.	IFM TYPE	ELECTRIC HEATER PART NUMBER CRHEATERXXXXXX	NOM PWR (kW)	APP PWR (kW)	SINGLE POINT KIT PART NUMBER CRSINGLEXXXXXX			
					NO C.O. or UNPWRD C.O.		w/PWRD C.O.	
					NO PE.	w/PE. (pwrd fr/unit)	NO PE.	w/PE. (pwrd fr/unit)
208/ 230-1-60	STD	102A00	6.5	4.9/6.0	-	-	-	-
		103B00	8.7	6.5/8.0	037A00	037A00	037A00	037A00
		102A00,102A00	13	9.8/11.9	040A00	040A00	040A00	040A00
		103B00,103B00	17.4	13.1/16.0	040A00	040A00	040A00	040A00
		104B00,104B00	21	15.8/19.3	040A00	040A00	040A00	040A00
	MED	102A00	6.5	4.9/6.0	-	-	-	037A00
		103B00	8.7	6.5/8.0	037A00	037A00	040A00	040A00
		102A00,102A00	13	9.8/11.9	040A00	040A00	040A00	040A00
		103B00,103B00	17.4	13.1/16.0	040A00	040A00	040A00	040A00
		104B00,104B00	21	15.8/19.3	040A00	040A00	040A00	040A00
208/ 230-3-60	STD	102A00	6.5	4.9/6.0	-	-	-	-
		104B00	10.5	7.9/9.6	-	-	-	-
		105A00	16	12.0/14.7	037A00	037A00	038A00	038A00
		104B00,104B00	21	15.8/19.3	038A00	038A00	038A00	038A00
		104B00,105A00	26.5	19.9/24.3	038A00	038A00	038A00	038A00
	MED	102A00	6.5	4.9/6.0	-	-	-	-
		104B00	10.5	7.9/9.6	-	-	-	-
		105A00	16	12.0/14.7	037A00	037A00	038A00	038A00
		104B00,104B00	21	15.8/19.3	038A00	038A00	038A00	038A00
		104B00,105A00	26.5	19.9/24.3	038A00	038A00	038A00	038A00
	HIGH	102A00	6.5	4.9/6.0	-	-	-	-
		104B00	10.5	7.9/9.6	-	-	-	-
		105A00	16	12.0/14.7	037A00	037A00	038A00	038A00
		104B00,104B00	21	15.8/19.3	038A00	038A00	038A00	038A00
		104B00,105A00	26.5	19.9/24.3	038A00	038A00	038A00	038A00
460-3-60	STD	106A00	6	5.5	-	-	-	-
		108A00	11.5	10.6	-	-	-	-
		109A00	14	12.9	-	-	-	-
		108A00,108A00	23	21.1	037A00	037A00	037A00	037A00
		108A00,109A00	25.5	23.4	037A00	037A00	037A00	037A00
	MED	106A00	6	5.5	-	-	-	-
		108A00	11.5	10.6	-	-	-	-
		109A00	14	12.9	-	-	-	-
		108A00,108A00	23	21.1	037A00	037A00	037A00	037A00
		108A00,109A00	25.5	23.4	037A00	037A00	037A00	037A00
	HIGH	106A00	6	5.5	-	-	-	-
		108A00	11.5	10.6	-	-	-	-
		109A00	14	12.9	-	-	-	-
		108A00,108A00	23	21.1	037A00	037A00	037A00	037A00
		108A00,109A00	25.5	23.4	037A00	037A00	037A00	037A00

LEGEND

- APP PWR - 208 / 230V / 460V / 575V
- C.O. - Convenience outlet
- FLA - Full load amps
- IFM - Indoor fan motor
- NOM PWR - 240V / 480V / 600V
- PE. - Power exhaust
- PWRD - Powered convenience outlet
- UNPWRD - Unpowered convenience outlet

ELECTRICAL INFORMATION

(UNITS PRODUCED PRIOR TO JULY 30, 2012) cont.

Table 15 (cont.) - 50TC*A07

ELECTRIC HEAT - ELECTRICAL DATA 1-STAGE COOLING 1-SPEED INDOOR FAN MOTOR

NOM. V-PH-Hz.	IFM TYPE	ELECTRIC HEATER PART NUMBER CRHEATERXXXXXX	NOM PWR (kW)	APP PWR (kW)	SINGLE POINT KIT PART NUMBER CRSINGLEXXXXXX			
					NO C.O. or UNPWRD C.O.		w/PWRD C.O.	
					NO PE.	w/PE. (pwrd fr/unit)	NO PE.	w/PE. (pwrd fr/unit)
208/ 230-3-60	STD	102A00	6.5	4.9/6.0	-	-	-	-
		104B00	10.5	7.9/9.6	-	-	-	-
		105A00	16.0	12.0/14.7	037A00	037A00	038A00	038A00
		104B00,104B00	21.0	15.8/19.3	038A00	038A00	038A00	038A00
		104B00,105A00	26.5	19.9/24.3	038A00	038A00	038A00	038A00
	MED	102A00	6.5	4.9/6.0	-	-	-	-
		104B00	10.5	7.9/9.6	-	-	-	-
		105A00	16.0	12.0/14.7	037A00	037A00	038A00	038A00
		104B00,104B00	21.0	15.8/19.3	038A00	038A00	038A00	038A00
	HIGH	104B00,105A00	26.5	19.9/24.3	038A00	038A00	038A00	038A00
		102A00	6.5	4.9/6.0	-	-	-	-
		104B00	10.5	7.9/9.6	-	-	-	-
460-3-60	STD	106A00	6.0	5.5	-	-	-	-
		108A00	11.5	10.6	-	-	-	-
		109A00	14.0	12.9	-	-	-	-
		108A00,108A00	23.0	21.1	037A00	037A00	037A00	037A00
		108A00,109A00	25.5	23.4	037A00	037A00	037A00	037A00
	MED	106A00	6.0	5.5	-	-	-	-
		108A00	11.5	10.6	-	-	-	-
		109A00	14.0	12.9	-	-	-	-
		108A00,108A00	23.0	21.1	037A00	037A00	037A00	037A00
	HIGH	108A00,109A00	25.5	23.4	037A00	037A00	037A00	037A00
		106A00	6.0	5.5	-	-	-	-
		108A00	11.5	10.6	-	-	-	-
HIGH	109A00	14.0	12.9	-	-	-	-	
	108A00,108A00	23.0	21.1	037A00	037A00	037A00	037A00	
	108A00,109A00	25.5	23.4	037A00	037A00	037A00	037A00	
	108A00,109A00	25.5	23.4	037A00	037A00	037A00	037A00	

LEGEND

- APP PWR - 208 / 230V / 460V / 575V
- C.O. - Convenience outlet
- FLA - Full load amps
- IFM - Indoor fan motor
- NOM PWR - 240V / 480V / 600V
- PE. - Power exhaust
- PWRD - Powered convenience outlet
- UNPWRD - Unpowered convenience outlet

ELECTRICAL INFORMATION

(UNITS PRODUCED PRIOR TO JULY 30, 2012) cont.

Table 15 (cont.) - 50TC*A08

ELECTRIC HEAT - ELECTRICAL DATA 1-STAGE COOLING 1-SPEED INDOOR FAN MOTOR

NOM. V-PH-Hz.	IFM TYPE	ELECTRIC HEATER PART NUMBER CRHEATERXXXXXX	NOM PWR (kW)	APP PWR (kW)	SINGLE POINT KIT PART NUMBER CRSINGLEXXXXXX			
					NO C.O. or UNPWRD C.O.		w/PWRD C.O.	
					NO PE.	w/PE. (pwrd fr/unit)	NO PE.	w/PE. (pwrd fr/unit)
208/ 230-3-60	STD	117A00	10.4	7.8/9.6	042A00	042A00	042A00	042A00
		110A00	16.0	12.0/14.7	042A00	042A00	043A00	043A00
		111A00	24.8	18.6/22.8	043A00	043A00	043A00	043A00
		112A00	32.0	24.0/29.4	043A00	043A00	043A00	043A00
		112A00,117A00	42.4	31.8/38.9	045A00	045A00	045A00	045A00
	MED	117A00	10.4	7.8/9.6	042A00	042A00	042A00	042A00
		110A00	16.0	12.0/14.7	042A00	043A00	043A00	043A00
		111A00	24.8	18.6/22.8	043A00	043A00	043A00	043A00
		112A00	32.0	24.0/29.4	043A00	043A00	043A00	043A00
		112A00,117A00	42.4	31.8/38.9	045A00	045A00	045A00	045A00
	HIGH	117A00	10.4	7.8/9.6	042A00	042A00	043A00	043A00
		110A00	16.0	12.0/14.7	043A00	043A00	043A00	043A00
111A00		24.8	18.6/22.8	043A00	043A00	043A00	043A00	
112A00		32.0	24.0/29.4	043A00	043A00	043A00	043A00	
112A00,117A00		42.4	31.8/38.9	045A00	045A00	045A00	045A00	
460-3-60	STD	116A00	13.9	12.8	042A00	042A00	042A00	042A00
		113A00	16.5	15.2	042A00	042A00	042A00	042A00
		114A00	27.8	25.5	042A00	042A00	042A00	042A00
		115A00	33.0	30.3	042A00	042A00	042A00	042A00
		114A00,116A00	41.7	38.3	044A00	044A00	044A00	044A00
	MED	116A00	13.9	12.8	042A00	042A00	042A00	042A00
		113A00	16.5	15.2	042A00	042A00	042A00	042A00
		114A00	27.8	25.5	042A00	042A00	042A00	042A00
		115A00	33.0	30.3	042A00	042A00	042A00	042A00
		114A00,116A00	41.7	38.3	044A00	044A00	044A00	044A00
	HIGH	116A00	13.9	12.8	042A00	042A00	042A00	042A00
		113A00	16.5	15.2	042A00	042A00	042A00	042A00
114A00		27.8	25.5	042A00	042A00	042A00	042A00	
115A00		33.0	30.3	042A00	044A00	044A00	044A00	
114A00,116A00		41.7	38.3	044A00	044A00	044A00	044A00	
575-3-60	STD	118A00	17.0	17.0	042A00	042A00	042A00	042A00
		119A00	34.0	34.0	042A00	042A00	042A00	044A00
	MED	118A00	17.0	17.0	042A00	042A00	042A00	042A00
		119A00	34.0	34.0	042A00	042A00	042A00	044A00
	HIGH	118A00	17.0	17.0	042A00	042A00	042A00	042A00
		119A00	34.0	34.0	042A00	044A00	044A00	044A00

LEGEND

- APP PWR - 208 / 230V / 460V / 575V
- C.O. - Convenience outlet
- FLA - Full load amps
- IFM - Indoor fan motor
- NOM PWR - 240V / 480V / 600V
- P.E. - Power exhaust
- PWRD - Powered convenience outlet
- UNPWRD - Unpowered convenience outlet

ELECTRICAL INFORMATION

(UNITS PRODUCED PRIOR TO JULY 30, 2012) cont.

Table 15 (cont.) - 50TC*D08

ELECTRIC HEAT - ELECTRICAL DATA 2-STAGE COOLING 1-SPEED INDOOR FAN MOTOR

NOM. V-PH-Hz.	IFM TYPE	ELECTRIC HEATER PART NUMBER CRHEATERXXXXXX	NOM PWR (kW)	APP PWR (kW)	SINGLE POINT KIT PART NUMBER CRSINGLEXXXXXX			
					NO C.O. or UNPWRD C.O.		w/PWRD C.O.	
					NO PE.	w/PE. (pwrd fr/unit)	NO PE.	w/PE. (pwrd fr/unit)
208/ 230-3-60	STD	117A00	10.4	7.8/9.6	042A00	042A00	042A00	042A00
		110A00	16.0	12.0/14.7	042A00	042A00	043A00	043A00
		111A00	24.8	18.6/22.8	043A00	043A00	043A00	043A00
		112A00	32.0	24.0/29.4	043A00	043A00	043A00	043A00
		112A00,117A00	42.4	31.8/38.9	045A00	045A00	045A00	045A00
	MED	117A00	10.4	7.8/9.6	042A00	042A00	042A00	042A00
		110A00	16.0	12.0/14.7	042A00	043A00	043A00	043A00
		111A00	24.8	18.6/22.8	043A00	043A00	043A00	043A00
		112A00	32.0	24.0/29.4	043A00	043A00	043A00	043A00
		112A00,117A00	42.4	31.8/38.9	045A00	045A00	045A00	045A00
	HIGH	117A00	10.4	7.8/9.6	042A00	042A00	042A00	043A00
		110A00	16.0	12.0/14.7	043A00	043A00	043A00	043A00
111A00		24.8	18.6/22.8	043A00	043A00	043A00	043A00	
112A00		32.0	24.0/29.4	043A00	043A00	043A00	043A00	
112A00,117A00		42.4	31.8/38.9	045A00	045A00	045A00	045A00	
460-3-60	STD	116A00	13.9	12.8	042A00	042A00	042A00	042A00
		113A00	16.5	15.2	042A00	042A00	042A00	042A00
		114A00	27.8	25.5	042A00	042A00	042A00	042A00
		115A00	33.0	30.3	042A00	042A00	042A00	042A00
		114A00,116A00	41.7	38.3	044A00	044A00	044A00	044A00
	MED	116A00	13.9	12.8	042A00	042A00	042A00	042A00
		113A00	16.5	15.2	042A00	042A00	042A00	042A00
		114A00	27.8	25.5	042A00	042A00	042A00	042A00
		115A00	33.0	30.3	042A00	042A00	042A00	042A00
		114A00,116A00	41.7	38.3	044A00	044A00	044A00	044A00
	HIGH	116A00	13.9	12.8	042A00	042A00	042A00	042A00
		113A00	16.5	15.2	042A00	042A00	042A00	042A00
114A00		27.8	25.5	042A00	042A00	042A00	042A00	
115A00		33.0	30.3	042A00	044A00	044A00	044A00	
114A00,116A00		41.7	38.3	044A00	044A00	044A00	044A00	
575-3-60	STD	118A00	17.0	17.0	042A00	042A00	042A00	042A00
		119A00	34.0	34.0	042A00	042A00	042A00	044A00
	MED	118A00	17.0	17.0	042A00	042A00	042A00	042A00
		119A00	34.0	34.0	042A00	042A00	042A00	044A00
	HIGH	118A00	17.0	17.0	042A00	042A00	042A00	042A00
		119A00	34.0	34.0	042A00	044A00	044A00	044A00

LEGEND

- APP PWR - 208 / 230V / 460V / 575V
- C.O. - Convenience outlet
- FLA - Full load amps
- IFM - Indoor fan motor
- NOM PWR - 240V / 480V / 600V
- P.E. - Power exhaust
- PWRD - Powered convenience outlet
- UNPWRD - Unpowered convenience outlet

ELECTRICAL INFORMATION

(UNITS PRODUCED PRIOR TO JULY 30, 2012) cont.

Table 15 (cont.) - 50TC*D08

ELECTRIC HEAT - ELECTRICAL DATA 2-STAGE COOLING 2-SPEED INDOOR FAN MOTOR

NOM. V-PH-Hz.	IFM TYPE	ELECTRIC HEATER PART NUMBER CRHEATERXXXXXX	NOM PWR (kW)	APP PWR (kW)	SINGLE POINT KIT PART NUMBER CRSINGLEXXXXXX			
					NO C.O. or UNPWRD C.O.		w/PWRD C.O.	
					NO PE.	w/PE. (pwrd fr/unit)	NO PE.	w/PE. (pwrd fr/unit)
208/ 230-3-60	STD	117A00	10.4	7.8/9.6	042A00	042A00	042A00	042A00
		110A00	16.0	12.0/14.7	042A00	042A00	043A00	043A00
		111A00	24.8	18.6/22.8	043A00	043A00	043A00	043A00
		112A00	32.0	24.0/29.4	043A00	043A00	043A00	043A00
		112A00,117A00	42.4	31.8/38.9	045A00	045A00	045A00	045A00
	MED	117A00	10.4	7.8/9.6	042A00	042A00	042A00	042A00
		110A00	16.0	12.0/14.7	042A00	043A00	043A00	043A00
		111A00	24.8	18.6/22.8	043A00	043A00	043A00	043A00
		112A00	32.0	24.0/29.4	043A00	043A00	043A00	043A00
		112A00,117A00	42.4	31.8/38.9	045A00	045A00	045A00	045A00
	HIGH	117A00	10.4	7.8/9.6	042A00	042A00	042A00	042A00
		110A00	16.0	12.0/14.7	043A00	043A00	043A00	043A00
		111A00	24.8	18.6/22.8	043A00	043A00	043A00	043A00
		112A00	32.0	24.0/29.4	043A00	043A00	043A00	043A00
		112A00,117A00	42.4	31.8/38.9	045A00	045A00	045A00	045A00
460-3-60	STD	116A00	13.9	12.8	042A00	042A00	042A00	042A00
		113A00	16.5	15.2	042A00	042A00	042A00	042A00
		114A00	27.8	25.5	042A00	042A00	042A00	042A00
		115A00	33.0	30.3	042A00	042A00	042A00	042A00
		114A00,116A00	41.7	38.3	044A00	044A00	044A00	044A00
	MED	116A00	13.9	12.8	042A00	042A00	042A00	042A00
		113A00	16.5	15.2	042A00	042A00	042A00	042A00
		114A00	27.8	25.5	042A00	042A00	042A00	042A00
		115A00	33.0	30.3	042A00	042A00	042A00	042A00
		114A00,116A00	41.7	38.3	044A00	044A00	044A00	044A00
	HIGH	116A00	13.9	12.8	042A00	042A00	042A00	042A00
		113A00	16.5	15.2	042A00	042A00	042A00	042A00
		114A00	27.8	25.5	042A00	042A00	042A00	042A00
		115A00	33.0	30.3	042A00	042A00	044A00	044A00
		114A00,116A00	41.7	38.3	044A00	044A00	044A00	044A00
575-3-60	STD	118A00	17.0	17.0	042A00	042A00	042A00	042A00
		119A00	34.0	34.0	042A00	042A00	042A00	044A00
	MED	118A00	17.0	17.0	042A00	042A00	042A00	042A00
		119A00	34.0	34.0	042A00	044A00	042A00	044A00
	HIGH	118A00	17.0	17.0	042A00	042A00	042A00	042A00
		119A00	34.0	34.0	042A00	044A00	044A00	044A00

LEGEND

- APP PWR - 208 / 230V / 460V / 575V
- C.O. - Convenience outlet
- FLA - Full load amps
- IFM - Indoor fan motor
- NOM PWR - 240V / 480V / 600V
- P.E. - Power exhaust
- PWRD - Powered convenience outlet
- UNPWRD - Unpowered convenience outlet

ELECTRICAL INFORMATION

(UNITS PRODUCED PRIOR TO JULY 30, 2012) cont.

Table 15 (cont.) - 50TC*A09

ELECTRIC HEAT - ELECTRICAL DATA 1-STAGE COOLING 1-SPEED INDOOR FAN MOTOR

NOM. V-PH-Hz.	IFM TYPE	ELECTRIC HEATER PART NUMBER CRHEATERXXXXXX	NOM PWR (kW)	APP PWR (kW)	SINGLE POINT KIT PART NUMBER CRSINGLEXXXXXX			
					NO C.O. or UNPWRD C.O.		w/PWRD C.O.	
					NO PE.	w/PE. (pwrd fr/unit)	NO PE.	w/PE. (pwrd fr/unit)
208/ 230-3-60	STD	117A00	10.4	7.8/9.6	047A00	047A00	047A00	049A00
		110A00	16.0	12.0/14.7	047A00	047A00	049A00	049A00
		111A00	24.8	18.6/22.8	049A00	049A00	049A00	049A00
		112A00	32.0	24.0/29.4	049A00	049A00	049A00	049A00
		112A00,117A00	42.4	31.8/38.9	051A00	051A00	051A00	051A00
	MED	117A00	10.4	7.8/9.6	047A00	047A00	047A00	049A00
		110A00	16.0	12.0/14.7	047A00	047A00	049A00	049A00
		111A00	24.8	18.6/22.8	049A00	049A00	049A00	049A00
		112A00	32.0	24.0/29.4	049A00	049A00	049A00	049A00
		112A00,117A00	42.4	31.8/38.9	051A00	051A00	051A00	051A00
	HIGH	117A00	10.4	7.8/9.6	047A00	049A00	049A00	049A00
		110A00	16.0	12.0/14.7	049A00	049A00	049A00	049A00
111A00		24.8	18.6/22.8	049A00	049A00	049A00	049A00	
112A00		32.0	24.0/29.4	049A00	049A00	049A00	049A00	
112A00,117A00		42.4	31.8/38.9	051A00	051A00	051A00	051A00	
460-3-60	STD	116A00	13.9	12.8	047A00	047A00	047A00	047A00
		113A00	16.5	15.2	047A00	047A00	047A00	047A00
		114A00	27.8	25.5	047A00	047A00	047A00	047A00
		115A00	33.0	30.3	047A00	047A00	047A00	047A00
		114A00,116A00	41.7	38.3	050A00	050A00	050A00	050A00
	MED	116A00	13.9	12.8	047A00	047A00	047A00	047A00
		113A00	16.5	15.2	047A00	047A00	047A00	047A00
		114A00	27.8	25.5	047A00	047A00	047A00	047A00
		115A00	33.0	30.3	047A00	047A00	047A00	047A00
		114A00,116A00	41.7	38.3	050A00	050A00	050A00	050A00
	HIGH	116A00	13.9	12.8	047A00	047A00	047A00	047A00
		113A00	16.5	15.2	047A00	047A00	047A00	047A00
		114A00	27.8	25.5	047A00	047A00	047A00	047A00
		115A00	33.0	30.3	047A00	047A00	047A00	050A00
		114A00,116A00	41.7	38.3	050A00	050A00	050A00	050A00
575-3-60	STD	118A00	17.0	17.0	047A00	047A00	047A00	047A00
		119A00	34.0	34.0	047A00	047A00	047A00	050A00
	MED	118A00	17.0	17.0	047A00	047A00	047A00	047A00
		119A00	34.0	34.0	047A00	047A00	047A00	050A00
	HIGH	118A00	17.0	17.0	047A00	047A00	047A00	047A00
		119A00	34.0	34.0	047A00	047A00	047A00	050A00

LEGEND

- APP PWR - 208 / 230V / 460V / 575V
- C.O. - Convenience outlet
- FLA - Full load amps
- IFM - Indoor fan motor
- NOM PWR - 240V / 480V / 600V
- PE. - Power exhaust
- PWRD - Powered convenience outlet
- UNPWRD - Unpowered convenience outlet

ELECTRICAL INFORMATION

(UNITS PRODUCED PRIOR TO JULY 30, 2012) cont.

Table 15 (cont.) - 50TC*D09

ELECTRIC HEAT - ELECTRICAL DATA 2-STAGE COOLING 1-SPEED INDOOR FAN MOTOR

NOM. V-PH-Hz.	IFM TYPE	ELECTRIC HEATER PART NUMBER CRHEATERXXXXXX	NOM PWR (kW)	APP PWR (kW)	SINGLE POINT KIT PART NUMBER CRSINGLEXXXXXX			
					NO C.O. or UNPWRD C.O.		w/PWRD C.O.	
					NO PE.	w/PE. (pwrd fr/unit)	NO PE.	w/PE. (pwrd fr/unit)
208/ 230-3-60	STD	117A00	10.4	7.8/9.6	047	047	047	047
		110A00	16.0	12.0/14.7	047	047	049	049
		111A00	24.8	18.6/22.8	049	049	049	049
		112A00	32.0	24.0/29.4	049	049	049	049
		112A00,117A00	42.4	31.8/38.9	051	051	051	051
	MED	117A00	10.4	7.8/9.6	047	047	047	047
		110A00	16.0	12.0/14.7	047	047	049	049
		111A00	24.8	18.6/22.8	049	049	049	049
		112A00	32.0	24.0/29.4	049	049	049	049
		112A00,117A00	42.4	31.8/38.9	051	051	051	051
	HIGH	117A00	10.4	7.8/9.6	047	047	047	047
		110A00	16.0	12.0/14.7	049	049	049	049
111A00		24.8	18.6/22.8	049	049	049	049	
112A00		32.0	24.0/29.4	049	049	049	049	
112A00,117A00		42.4	31.8/38.9	051	051	051	051	
460-3-60	STD	116A00	13.9	12.8	047	047	047	047
		113A00	16.5	15.2	047	047	047	047
		114A00	27.8	25.5	047	047	047	047
		115A00	33.0	30.3	047	047	047	047
		114A00,116A00	41.7	38.3	050	050	050	050
	MED	116A00	13.9	12.8	047	047	047	047
		113A00	16.5	15.2	047	047	047	047
		114A00	27.8	25.5	047	047	047	047
		115A00	33.0	30.3	047	047	047	047
		114A00,116A00	41.7	38.3	050	050	050	050
	HIGH	116A00	13.9	12.8	047	047	047	047
		113A00	16.5	15.2	047	047	047	047
114A00		27.8	25.5	047	047	047	047	
115A00		33.0	30.3	047	047	047	050	
114A00,116A00		41.7	38.3	050	050	050	050	
575-3-60	STD	118A00	17.0	17.0	047	047	047	047
		119A00	34.0	34.0	047	047	047	050
	MED	118A00	17.0	17.0	047	047	047	047
		119A00	34.0	34.0	047	047	047	050
	HIGH	118A00	17.0	17.0	047	047	047	047
		119A00	34.0	34.0	047	047	047	050

LEGEND

- APP PWR - 208 / 230V / 460V / 575V
- C.O. - Convenience outlet
- FLA - Full load amps
- IFM - Indoor fan motor
- NOM PWR - 240V / 480V / 600V
- PE. - Power exhaust
- PWRD - Powered convenience outlet
- UNPWRD - Unpowered convenience outlet

ELECTRICAL INFORMATION

(UNITS PRODUCED PRIOR TO JULY 30, 2012) cont.

Table 15 (cont.) - 50TC*D09

ELECTRIC HEAT - ELECTRICAL DATA 2-STAGE COOLING 2-SPEED INDOOR FAN MOTOR

NOM. V-PH-Hz.	IFM TYPE	ELECTRIC HEATER PART NUMBER CRHEATERXXXXXX	NOM PWR (kW)	APP PWR (kW)	SINGLE POINT KIT PART NUMBER CRSINGLEXXXXXX			
					NO C.O. or UNPWRD C.O.		w/PWRD C.O.	
					NO P.E.	w/P.E. (pwrd fr/unit)	NO P.E.	w/P.E. (pwrd fr/ unit)
208/ 203-3-60	STD	117A00	10.4	7.8/9.6	047A00	047A00	047A00	047A00
		110A00	16.0	12.0/14.7	047A00	047A00	049A00	049A00
		111A00	24.8	18.6/22.8	049A00	049A00	049A00	049A00
		112A00	32.0	24.0/29.4	049A00	049A00	049A00	049A00
		112A00,117A00	42.4	31.8/38.9	051A00	051A00	051A00	051A00
	MED	117A00	10.4	7.8/9.6	047A00	047A00	047A00	047A00
		110A00	16.0	12.0/14.7	047A00	049A00	049A00	049A00
		111A00	24.8	18.6/22.8	049A00	049A00	049A00	049A00
		112A00	32.0	24.0/29.4	049A00	049A00	049A00	049A00
		112A00,117A00	42.4	31.8/38.9	051A00	051A00	051A00	051A00
	HIGH	117A00	10.4	7.8/9.6	047A00	047A00	047A00	047A00
		110A00	16.0	12.0/14.7	049A00	049A00	049A00	049A00
111A00		24.8	18.6/22.8	049A00	049A00	049A00	049A00	
112A00		32.0	24.0/29.4	049A00	049A00	049A00	049A00	
112A00,117A00		42.4	31.8/38.9	051A00	051A00	051A00	051A00	
460-3-60	STD	116A00	13.9	12.8	047A00	047A00	047A00	047A00
		113A00	16.5	15.2	047A00	047A00	047A00	047A00
		114A00	27.8	25.5	047A00	047A00	047A00	047A00
		115A00	33.0	30.3	047A00	047A00	047A00	047A00
		114A00,116A00	41.7	38.3	050A00	050A00	050A00	050A00
	MED	116A00	13.9	12.8	047A00	047A00	047A00	047A00
		113A00	16.5	15.2	047A00	047A00	047A00	047A00
		114A00	27.8	25.5	047A00	047A00	047A00	047A00
		115A00	33.0	30.3	047A00	047A00	047A00	047A00
		114A00,116A00	41.7	38.3	050A00	050A00	050A00	050A00
	HIGH	116A00	13.9	12.8	047A00	047A00	047A00	047A00
		113A00	16.5	15.2	047A00	047A00	047A00	047A00
114A00		27.8	25.5	047A00	047A00	047A00	047A00	
115A00		33.0	30.3	047A00	047A00	047A00	050A00	
114A00,116A00		41.7	38.3	050A00	050A00	050A00	050A00	
575-3-60	STD	118A00	17.0	17.0	047A00	047A00	047A00	047A00
		119A00	34.0	34.0	047A00	047A00	047A00	050A00
	MED	118A00	17.0	17.0	047A00	047A00	047A00	047A00
		119A00	34.0	34.0	047A00	050A00	047A00	050A00
	HIGH	118A00	17.0	17.0	047A00	047A00	047A00	047A00
		119A00	34.0	34.0	047A00	050A00	047A00	050A00

LEGEND

- APP PWR - 208 / 230V / 460V / 575V
- C.O. - Convenience outlet
- FLA - Full load amps
- IFM - Indoor fan motor
- NOM PWR - 240V / 480V / 600V
- P.E. - Power exhaust
- PWRD - Powered convenience outlet
- UNPWRD - Unpowered convenience outlet

ELECTRICAL INFORMATION

(UNITS PRODUCED PRIOR TO JULY 30, 2012) cont.

Table 15 (cont.) - 50TC*A12

ELECTRIC HEAT - ELECTRICAL DATA 1-STAGE COOLING 1-SPEED INDOOR FAN MOTOR

NOM. V-PH-Hz.	IFM TYPE	ELECTRIC HEATER PART NUMBER CRHEATERXXXXXX	NOM PWR (kW)	APP PWR (kW)	SINGLE POINT KIT PART NUMBER CRSINGLEXXXXXX			
					NO C.O. or UNPWRD C.O.		w/PWRD C.O.	
					NO PE.	w/PE. (pwrd fr/unit)	NO PE.	w/PE. (pwrd fr/unit)
208/ 230-3-60	STD	117A00	10.4	7.8/9.6	047A00	047A00	047A00	049A00
		110A00	16.0	12.0/14.7	047A00	047A00	049A00	049A00
		112A00	32.0	24.0/29.4	049A00	049A00	049A00	049A00
		112A00,117A00	42.4	31.8/38.9	051A00	051A00	051A00	051A00
		112A00,110A00	50.0	37.6/45.9	051A00	051A00	051A00	051A00
	MED	117A00	10.4	7.8/9.6	047A00	049A00	049A00	049A00
		110A00	16.0	12.0/14.7	049A00	049A00	049A00	049A00
		112A00	32.0	24.0/29.4	049A00	049A00	049A00	049A00
		112A00,117A00	42.4	31.8/38.9	051A00	051A00	051A00	051A00
		112A00,110A00	50.0	37.6/45.9	051A00	051A00	051A00	051A00
	HIGH	117A00	10.4	7.8/9.6	049A00	049A00	049A00	049A00
		110A00	16.0	12.0/14.7	049A00	049A00	049A00	049A00
		112A00	32.0	24.0/29.4	049A00	049A00	049A00	049A00
		112A00,117A00	42.4	31.8/38.9	051A00	051A00	051A00	051A00
		112A00,110A00	50.0	37.6/45.9	051A00	051A00	051A00	051A00
460-3-60	STD	116A00	13.9	12.8	047A00	047A00	047A00	047A00
		113A00	16.5	15.2	047A00	047A00	047A00	047A00
		115A00	33.0	30.3	047A00	047A00	047A00	047A00
		114A00,116A00	41.7	38.3	050A00	050A00	050A00	050A00
		115A00,113A00	50.0	45.9	050A00	050A00	050A00	050A00
	MED	116A00	13.9	12.8	047A00	047A00	047A00	047A00
		113A00	16.5	15.2	047A00	047A00	047A00	047A00
		115A00	33.0	30.3	047A00	047A00	047A00	050A00
		114A00,116A00	41.7	38.3	050A00	050A00	050A00	050A00
		115A00,113A00	50.0	45.9	050A00	050A00	050A00	050A00
	HIGH	116A00	13.9	12.8	047A00	047A00	047A00	047A00
		113A00	16.5	15.2	047A00	047A00	047A00	047A00
		115A00	33.0	30.3	047A00	050A00	050A00	050A00
		114A00,116A00	41.7	38.3	050A00	050A00	050A00	050A00
		115A00,113A00	50.0	45.9	050A00	050A00	050A00	050A00
575-3-60	STD	118A00	17.0	17.0	047A00	047A00	047A00	047A00
		119A00	34.0	34.0	047A00	047A00	047A00	050A00
		118A00,119A00	51.0	51.0	050A00	050A00	050A00	050A00
	MED	118A00	17.0	17.0	047A00	047A00	047A00	047A00
		119A00	34.0	34.0	047A00	047A00	047A00	050A00
		118A00,119A00	51.0	51.0	050A00	050A00	050A00	050A00
	HIGH	118A00	17.0	17.0	047A00	047A00	047A00	047A00
		119A00	34.0	34.0	047A00	050A00	050A00	050A00
		118A00,119A00	51.0	51.0	050A00	050A00	050A00	050A00

LEGEND

- APP PWR - 208 / 230V / 460V / 575V
- C.O. - Convenience outlet
- FLA - Full load amps
- IFM - Indoor fan motor
- NOM PWR - 240V / 480V / 600V
- PE. - Power exhaust
- PWRD - Powered convenience outlet
- UNPWRD - Unpowered convenience outlet

ELECTRICAL INFORMATION

(UNITS PRODUCED PRIOR TO JULY 30, 2012) cont.

Table 15 (cont.) - 50TC*D12

ELECTRIC HEAT - ELECTRICAL DATA 2-STAGE COOLING 1-SPEED INDOOR FAN MOTOR

NOM. V-PH-Hz.	IFM TYPE	ELECTRIC HEATER PART NUMBER CRHEATERXXXXXX	NOM PWR (kW)	APP PWR (kW)	SINGLE POINT KIT PART NUMBER CRSINGLEXXXXXX			
					NO C.O. or UNPWRD C.O.		w/PWRD C.O.	
					NO PE.	w/PE. (pwrd fr/unit)	NO PE.	w/PE. (pwrd fr/unit)
208/ 230-3-60	STD	117A00	10.4	7.8/9.6	047A00	047A00	047A00	047A00
		110A00	16.0	12.0/14.7	047A00	047A00	049A00	049A00
		112A00	32.0	24.0/29.4	049A00	049A00	049A00	049A00
		112A00,117A00	42.4	31.8/38.9	051A00	051A00	051A00	051A00
		112A00,110A00	50.0	37.6/45.9	051A00	051A00	051A00	051A00
	MED	117A00	10.4	7.8/9.6	047A00	047A00	047A00	049A00
		110A00	16.0	12.0/14.7	049A00	049A00	049A00	049A00
		112A00	32.0	24.0/29.4	049A00	049A00	049A00	049A00
		112A00,117A00	42.4	31.8/38.9	051A00	051A00	051A00	051A00
		112A00,110A00	50.0	37.6/45.9	051A00	051A00	051A00	051A00
	HIGH	117A00	10.4	7.8/9.6	047A00	049A00	049A00	049A00
		110A00	16.0	12.0/14.7	049A00	049A00	049A00	049A00
		112A00	32.0	24.0/29.4	049A00	049A00	049A00	049A00
		112A00,117A00	42.4	31.8/38.9	051A00	051A00	051A00	051A00
		112A00,110A00	50.0	37.6/45.9	051A00	051A00	051A00	051A00
460-3-60	STD	116A00	13.9	12.8	047A00	047A00	047A00	047A00
		113A00	16.5	15.2	047A00	047A00	047A00	047A00
		115A00	33.0	30.3	047A00	047A00	047A00	047A00
		114A00,116A00	41.7	38.3	050A00	050A00	050A00	050A00
		115A00,113A00	50.0	45.9	050A00	050A00	050A00	050A00
	MED	116A00	13.9	12.8	047A00	047A00	047A00	047A00
		113A00	16.5	15.2	047A00	047A00	047A00	047A00
		115A00	33.0	30.3	047A00	047A00	047A00	050A00
		114A00,116A00	41.7	38.3	050A00	050A00	050A00	050A00
		115A00,113A00	50.0	45.9	050A00	050A00	050A00	050A00
	HIGH	116A00	13.9	12.8	047A00	047A00	047A00	047A00
		113A00	16.5	15.2	047A00	047A00	047A00	047A00
		115A00	33.0	30.3	047A00	050A00	050A00	050A00
		114A00,116A00	41.7	38.3	050A00	050A00	050A00	050A00
		115A00,113A00	50.0	45.9	050A00	050A00	050A00	050A00
575-3-60	STD	118A00	17.0	17.0	047A00	047A00	047A00	047A00
		119A00	34.0	34.0	047A00	047A00	047A00	050A00
		118A00,119A00	51.0	51.0	050A00	050A00	050A00	050A00
	MED	118A00	17.0	17.0	047A00	047A00	047A00	047A00
		119A00	34.0	34.0	047A00	047A00	047A00	050A00
		118A00,119A00	51.0	51.0	050A00	050A00	050A00	050A00
	HIGH	118A00	17.0	17.0	047A00	047A00	047A00	047A00
		119A00	34.0	34.0	047A00	050A00	050A00	050A00
		118A00,119A00	51.0	51.0	050A00	050A00	050A00	050A00

LEGEND

- APP PWR - 208 / 230V / 460V / 575V
- C.O. - Convenience outlet
- FLA - Full load amps
- IFM - Indoor fan motor
- NOM PWR - 240V / 480V / 600V
- PE. - Power exhaust
- PWRD - Powered convenience outlet
- UNPWRD - Unpowered convenience outlet

ELECTRICAL INFORMATION

(UNITS PRODUCED PRIOR TO JULY 30, 2012) cont.

Table 15 (cont.) - 50TC*D12

ELECTRIC HEAT - ELECTRICAL DATA 2-STAGE COOLING 2-SPEED INDOOR FAN MOTOR

NOM. V-PH-Hz.	IFM TYPE	ELECTRIC HEATER PART NUMBER CRHEATERXXXXXX	NOM PWR (kW)	APP PWR (kW)	SINGLE POINT KIT PART NUMBER CRSINGLEXXXXXX			
					NO C.O. or UNPWRD C.O.		w/PWRD C.O.	
					NO P.E.	w/P.E. (pwrd fr/unit)	NO P.E.	w/P.E. (pwrd fr/ unit)
208/ 230-3-60	STD	117A00	10.4	7.8/9.6	047A00	047A00	047A00	047A00
		110A00	16.0	12.0/14.7	047A00	049A00	049A00	049A00
		112A00	32.0	24.0/29.4	049A00	049A00	049A00	049A00
		112A00,117A00	42.4	31.8/38.9	051A00	051A00	051A00	051A00
		112A00,110A00	50.0	37.6/45.9	051A00	051A00	051A00	051A00
	MED	117A00	10.4	7.8/9.6	047A00	047A00	047A00	049A00
		110A00	16.0	12.0/14.7	049A00	049A00	049A00	049A00
		112A00	32.0	24.0/29.4	049A00	049A00	049A00	049A00
		112A00,117A00	42.4	31.8/38.9	051A00	051A00	051A00	051A00
		112A00,110A00	50.0	37.6/45.9	051A00	051A00	051A00	051A00
	HIGH	117A00	10.4	7.8/9.6	047A00	047A00	049A00	049A00
		110A00	16.0	12.0/14.7	049A00	049A00	049A00	049A00
		112A00	32.0	24.0/29.4	049A00	049A00	049A00	049A00
		112A00,117A00	42.4	31.8/38.9	051A00	051A00	051A00	051A00
		112A00,110A00	50.0	37.6/45.9	051A00	051A00	051A00	051A00
460-3-60	STD	116A00	13.9	12.8	047A00	047A00	047A00	047A00
		113A00	16.5	15.2	047A00	047A00	047A00	047A00
		115A00	33.0	30.3	047A00	047A00	047A00	047A00
		114A00,116A00	41.7	38.3	050A00	050A00	050A00	050A00
		115A00,113A00	50.0	45.9	050A00	050A00	050A00	050A00
	MED	116A00	13.9	12.8	047A00	047A00	047A00	047A00
		113A00	16.5	15.2	047A00	047A00	047A00	047A00
		115A00	33.0	30.3	047A00	047A00	047A00	050A00
		114A00,116A00	41.7	38.3	050A00	050A00	050A00	050A00
		115A00,113A00	50.0	45.9	050A00	050A00	050A00	050A00
	HIGH	116A00	13.9	12.8	047A00	047A00	047A00	047A00
		113A00	16.5	15.2	047A00	047A00	047A00	047A00
		115A00	33.0	30.3	047A00	047A00	050A00	050A00
		114A00,116A00	41.7	38.3	050A00	050A00	050A00	050A00
		115A00,113A00	50.0	45.9	050A00	050A00	050A00	050A00
575-3-60	STD	118A00	17.0	17.0	047A00	047A00	047A00	047A00
		119A00	34.0	34.0	047A00	050A00	047A00	050A00
		118A00,119A00	51.0	51.0	050A00	050A00	050A00	050A00
	MED	118A00	17.0	17.0	047A00	047A00	047A00	047A00
		119A00	34.0	34.0	047A00	050A00	047A00	050A00
		118A00,119A00	51.0	51.0	050A00	050A00	050A00	050A00
	HIGH	118A00	17.0	17.0	047A00	047A00	047A00	047A00
		119A00	34.0	34.0	047A00	050A00	050A00	050A00
		118A00,119A00	51.0	51.0	050A00	050A00	050A00	050A00

LEGEND

- APP PWR - 208 / 230V / 460V / 575V
- C.O. - Convenience outlet
- FLA - Full load amps
- IFM - Indoor fan motor
- NOM PWR - 240V / 480V / 600V
- P.E. - Power exhaust
- PWRD - Powered convenience outlet
- UNPWRD - Unpowered convenience outlet

ELECTRICAL INFORMATION

(UNITS PRODUCED PRIOR TO JULY 30, 2012) cont.

Table 15 (cont.) - 50TC*D14

ELECTRIC HEAT - ELECTRICAL DATA 2-STAGE COOLING 1-SPEED INDOOR FAN MOTOR

NOM. V-PH.HZ.	IFM TYPE	ELECTRIC HEATER PART NUMBER CRHEATERXXXXXX	NOM PWR (kW)	APP PWR (kW)	SINGLE POINT KIT PART NUMBER CRSINGLEXXXXXX			
					NO C.O. or UNPWRD C.O.		w/PWRD C.O.	
					NO PE.	w/PE. (pwrd fr/unit)	NO PE.	w/PE. (pwrd fr/unit)
208/ 230-3/60	STD	117A00	10.4	7.8/9.6	049A00	049A00	049A00	049A00
		110A00	16.0	12.0/14.7	049A00	049A00	049A00	049A00
		112A00	32.0	24.0/29.4	049A00	049A00	049A00	049A00
		112A00,117A00	42.4	31.8/38.9	051A00	051A00	051A00	051A00
		112A00,110A00	50.0	37.6/45.9	051A00	051A00	051A00	051A00
	MED	117A00	10.4	7.8/9.6	049A00	049A00	049A00	049A00
		110A00	16.0	12.0/14.7	049A00	049A00	049A00	049A00
		112A00	32.0	24.0/29.4	049A00	049A00	049A00	049A00
		112A00,117A00	42.4	31.8/38.9	051A00	051A00	051A00	051A00
		112A00,110A00	50.0	37.6/45.9	051A00	051A00	051A00	051A00
	HIGH	Std Unit Without Heat	-	-	-	-	-	049A00
		117A00	10.4	7.8/9.6	049A00	049A00	049A00	049A00
		110A00	16.0	12.0/14.7	049A00	049A00	049A00	049A00
		112A00	32.0	24.0/29.4	049A00	049A00	049A00	049A00
		112A00,117A00	42.4	31.8/38.9	051A00	051A00	051A00	051A00
112A00,110A00	50.0	37.6/45.9	051A00	051A00	051A00	051A00		
460-3-60	STD	116A00	13.9	12.8	047A00	047A00	047A00	047A00
		113A00	16.5	15.2	047A00	047A00	047A00	047A00
		115A00	33.0	30.3	047A00	047A00	047A00	047A00
		114A00,116A00	41.7	38.3	050A00	050A00	050A00	050A00
		115A00,113A00	50.0	45.9	050A00	050A00	050A00	050A00
	MED	116A00	13.9	12.8	047A00	047A00	047A00	047A00
		113A00	16.5	15.2	047A00	047A00	047A00	047A00
		115A00	33.0	30.3	047A00	047A00	047A00	050A00
		114A00,116A00	41.7	38.3	050A00	050A00	050A00	050A00
		115A00,113A00	50.0	45.9	050A00	050A00	050A00	050A00
	HIGH	116A00	13.9	12.8	047A00	047A00	047A00	047A00
		113A00	16.5	15.2	047A00	047A00	047A00	047A00
		115A00	33.0	30.3	047A00	050A00	050A00	050A00
		114A00,116A00	41.7	38.3	050A00	050A00	050A00	050A00
		115A00,113A00	50.0	45.9	050A00	050A00	050A00	050A00
575-3-60	STD	118A00	17.0	17.0	047A00	047A00	047A00	047A00
		119A00	34.0	34.0	047A00	047A00	047A00	050A00
		118A00,119A00	51.0	51.0	050A00	050A00	050A00	050A00
	MED	118A00	17.0	17.0	047A00	047A00	047A00	047A00
		119A00	34.0	34.0	047A00	047A00	047A00	050A00
		118A00,119A00	51.0	51.0	050A00	050A00	050A00	050A00
	HIGH	118A00	17.0	17.0	047A00	047A00	047A00	047A00
		119A00	34.0	34.0	047A00	050A00	050A00	050A00
		118A00,119A00	51.0	51.0	050A00	050A00	050A00	050A00

LEGEND

- APP PWR - 208 / 230V / 460V / 575V
- C.O. - Convenience outlet
- FLA - Full load amps
- IFM - Indoor fan motor
- NOM PWR - 240V / 480V / 600V
- PE. - Power exhaust
- PWRD - Powered convenience outlet
- UNPWRD - Unpowered convenience outlet

ELECTRICAL INFORMATION

(UNITS PRODUCED PRIOR TO JULY 30, 2012) cont.

Table 15 (cont.) - 50TC*D14

ELECTRIC HEAT - ELECTRICAL DATA 2-STAGE COOLING 2-SPEED INDOOR FAN MOTOR

NOM. V-PH-Hz.	IFM TYPE	ELECTRIC HEATER PART NUMBER CRHEATERXXXXXX	NOM PWR (kW)	APP PWR (kW)	SINGLE POINT KIT PART NUMBER CRSINGLEXXXXXX			
					NO C.O. or UNPWRD C.O.		w/PWRD C.O.	
					NO P.E.	w/P.E. (pwrd fr/unit)	NO P.E.	w/P.E. (pwrd fr/unit)
208/ 230-3-60	STD	117A00	10.4	7.8/9.6	049A00	049A00	049A00	049A00
		110A00	16.0	12.0/14.7	049A00	049A00	049A00	049A00
		112A00	32.0	24.0/29.4	049A00	049A00	049A00	049A00
		112A00,117A00	42.4	31.8/38.9	051A00	051A00	051A00	051A00
		112A00,110A00	50.0	37.6/45.9	051A00	051A00	051A00	051A00
	MED	117A00	10.4	7.8/9.6	049A00	049A00	049A00	049A00
		110A00	16.0	12.0/14.7	049A00	049A00	049A00	049A00
		112A00	32.0	24.0/29.4	049A00	049A00	049A00	049A00
		112A00,117A00	42.4	31.8/38.9	051A00	051A00	051A00	051A00
		112A00,110A00	50.0	37.6/45.9	051A00	051A00	051A00	051A00
		117A00	10.4	7.8/9.6	049A00	049A00	049A00	049A00
		110A00	16.0	12.0/14.7	049A00	049A00	049A00	049A00
		112A00	32.0	24.0/29.4	049A00	049A00	049A00	049A00
		112A00,117A00	42.4	31.8/38.9	051A00	051A00	051A00	051A00
		112A00,110A00	50.0	37.6/45.9	051A00	051A00	051A00	051A00
460-3-60	STD	116A00	13.9	12.8	047A00	047A00	047A00	047A00
		113A00	16.5	15.2	047A00	047A00	047A00	047A00
		115A00	33.0	30.3	047A00	047A00	047A00	047A00
		114A00,116A00	41.7	38.3	050A00	050A00	050A00	050A00
		115A00,113A00	50.0	45.9	050A00	050A00	050A00	050A00
	MED	116A00	13.9	12.8	047A00	047A00	047A00	047A00
		113A00	16.5	15.2	047A00	047A00	047A00	047A00
		115A00	33.0	30.3	047A00	047A00	047A00	050A00
		114A00,116A00	41.7	38.3	050A00	050A00	050A00	050A00
		115A00,113A00	50.0	45.9	050A00	050A00	050A00	050A00
	HIGH	116A00	13.9	12.8	047A00	047A00	047A00	047A00
		113A00	16.5	15.2	047A00	047A00	047A00	047A00
		115A00	33.0	30.3	047A00	047A00	050A00	050A00
		114A00,116A00	41.7	38.3	050A00	050A00	050A00	050A00
		115A00,113A00	50.0	45.9	050A00	050A00	050A00	050A00
575-3-60	STD	118A00	17.0	17.0	047A00	047A00	047A00	047A00
		119A00	34.0	34.0	047A00	050A00	047A00	050A00
		118A00,119A00	51.0	51.0	050A00	050A00	050A00	050A00
	MED	118A00	17.0	17.0	047A00	047A00	047A00	047A00
		119A00	34.0	34.0	047A00	050A00	047A00	050A00
		118A00,119A00	51.0	51.0	050A00	050A00	050A00	050A00
	HIGH	118A00	17.0	17.0	047A00	047A00	047A00	047A00
		119A00	34.0	34.0	047A00	050A00	050A00	050A00
		118A00,119A00	51.0	51.0	050A00	050A00	050A00	050A00

LEGEND

- APP PWR - 208 / 230V / 460V / 575V
- C.O. - Convenience outlet
- FLA - Full load amps
- IFM - Indoor fan motor
- NOM PWR - 240V / 480V / 600V
- P.E. - Power exhaust
- PWRD - Powered convenience outlet
- UNPWRD - Unpowered convenience outlet

ELECTRICAL INFORMATION

(UNITS PRODUCED PRIOR TO JULY 30, 2012) cont.

Table 15 (cont.) - 50TC*D16

ELECTRIC HEAT - ELECTRICAL DATA 2-STAGE COOLING 1-SPEED INDOOR FAN MOTOR

NOM. V-PH-Hz.	IFM TYPE	ELECTRIC HEATER PART NUMBER CRHEATERXXXXXX	NOM PWR (kW)	APP PWR (kW)	SINGLE POINT KIT PART NUMBER CRSINGLEXXXXXX			
					NO C.O. or UNPWRD C.O.		w/PWRD C.O.	
					NO P.E.	w/PE. (pwrd fr/unit)	NO P.E.	w/PE. (pwrd fr/unit)
208/ 230-3-60	STD	291A00	16.5	12.4/15.2	049A00	049A00	049A00	049A00
		294A00	33.5	25.2/30.8	049A00	049A00	049A00	049A00
		288A00,294A00	43.5	32.7/40.0	051A00	051A00	051A00	051A00
		291A00,294A00	50.0	37.6/45.9	051A00	051A00	051A00	051A00
		294A00,294A00	67.0	50.3/61.5	053A00	053A00	053A00	053A00
	MED	291A00	16.5	12.4/15.2	049A00	049A00	049A00	049A00
		294A00	33.5	25.2/30.8	049A00	049A00	049A00	049A00
		288A00,294A00	43.5	32.7/40.0	051A00	051A00	051A00	051A00
		291A00,294A00	50.0	37.6/45.9	051A00	051A00	051A00	051A00
		294A00,294A00	67.0	50.3/61.5	053A00	053A00	053A00	053A00
	HIGH	291A00	16.5	12.4/15.2	049A00	049A00	049A00	049A00
		294A00	33.5	25.2/30.8	049A00	049A00	049A00	049A00
288A00,294A00		43.5	32.7/40.0	051A00	051A00	051A00	051A00	
291A00,294A00		50.0	37.6/45.9	051A00	051A00	051A00	051A00	
294A00,294A00		67.0	50.3/61.5	053A00	053A00	053A00	053A00	
460-3-60	STD	292A00	16.5	15.2	-	-	-	-
		295A00	33.5	30.8	047A00	047A00	047A00	047A00
		289A00,295A00	43.5	40.0	050A00	050A00	050A00	050A00
		292A00,295A00	50.0	45.9	050A00	050A00	050A00	050A00
		295A00,295A00	67.0	61.5	050A00	050A00	050A00	050A00
	MED	292A00	16.5	15.2	-	-	-	-
		295A00	33.5	30.8	047A00	047A00	047A00	050A00
		289A00,295A00	43.5	40.0	050A00	050A00	050A00	050A00
		292A00,295A00	50.0	45.9	050A00	050A00	050A00	050A00
		295A00,295A00	67.0	61.5	050A00	050A00	050A00	050A00
	HIGH	292A00	16.5	15.2	-	-	-	-
		295A00	33.5	30.8	050A00	050A00	050A00	050A00
289A00,295A00		43.5	40.0	050A00	050A00	050A00	050A00	
292A00,295A00		50.0	45.9	050A00	050A00	050A00	050A00	
295A00,295A00		67.0	61.5	050A00	050A00	050A00	050A00	
575-3-60	STD	293A00	16.5	15.2	-	-	-	-
		296A00	33.5	30.8	047A00	047A00	047A00	047A00
		290A00,296A00	43.5	40.0	047A00	050A00	047A00	050A00
		293A00,296A00	50.0	45.9	047A00	047A00	047A00	047A00
		296A00,296A00	67.0	61.5	050A00	050A00	050A00	050A00
	MED	293A00	16.5	15.2	-	-	-	-
		296A00	33.5	30.8	047A00	047A00	047A00	047A00
		290A00,296A00	43.5	40.0	047A00	050A00	047A00	050A00
		293A00,296A00	50.0	45.9	047A00	047A00	047A00	047A00
		296A00,296A00	67.0	61.5	050A00	050A00	050A00	050A00
	HIGH	293A00	16.5	15.2	-	-	-	-
		296A00	33.5	30.8	047A00	047A00	047A00	047A00
290A00,296A00		43.5	40.0	050A00	050A00	050A00	050A00	
293A00,296A00		50.0	45.9	050A00	050A00	050A00	050A00	
296A00,296A00		67.0	61.5	050A00	050A00	050A00	050A00	

LEGEND

- APP PWR - 208 / 230V / 460V / 575V
- C.O. - Convenience outlet
- FLA - Full load amps
- IFM - Indoor fan motor
- NOM PWR - 240V / 480V / 600V
- P.E. - Power exhaust
- PWRD - Powered convenience outlet
- UNPWRD - Unpowered convenience outlet

ELECTRICAL INFORMATION

(UNITS PRODUCED PRIOR TO JULY 30, 2012) cont.

Table 15 (cont.) - 50TC*D16

ELECTRIC HEAT - ELECTRICAL DATA 2-STAGE COOLING 2-SPEED INDOOR FAN MOTOR

NOM. V-PH-Hz.	IFM TYPE	ELECTRIC HEATER PART NUMBER CRHEATERXXXXXX	NOM PWR (kW)	APP PWR (kW)	SINGLE POINT KIT PART NUMBER CRSINGLEXXXXXX			
					NO C.O. or UNPWRD C.O.		w/PWRD C.O.	
					NO P.E.	w/P.E. (pwrd fr/unit)	NO P.E.	w/P.E. (pwrd fr/unit)
208/ 230-3-60	STD	291A00	16.5	12.4/15.2	049A00	049A00	049A00	049A00
		294A00	33.5	25.2/30.8	049A00	049A00	049A00	049A00
		288A00,294A00	43.5	32.7/40.0	051A00	051A00	051A00	051A00
		291A00,294A00	50.0	37.6/45.9	051A00	051A00	051A00	051A00
		294A00,294A00	67.0	50.3/61.5	053A00	053A00	053A00	053A00
	MED	291A00	16.5	12.4/15.2	049A00	049A00	049A00	049A00
		294A00	33.5	25.2/30.8	049A00	049A00	049A00	049A00
		288A00,294A00	43.5	32.7/40.0	051A00	051A00	051A00	051A00
		291A00,294A00	50.0	37.6/45.9	051A00	051A00	051A00	051A00
		294A00,294A00	67.0	50.3/61.5	053A00	053A00	053A00	053A00
	HIGH	291A00	16.5	12.4/15.2	049A00	049A00	049A00	049A00
		294A00	33.5	25.2/30.8	049A00	049A00	049A00	049A00
288A00,294A00		43.5	32.7/40.0	051A00	051A00	051A00	051A00	
291A00,294A00		50.0	37.6/45.9	051A00	051A00	051A00	051A00	
294A00,294A00		67.0	50.3/61.5	053A00	053A00	053A00	053A00	
460-3-60	STD	292A00	16.5	15.2	-	-	-	-
		295A00	33.5	30.8	047A00	047A00	047A00	050A00
		289A00,295A00	43.5	40.0	050A00	050A00	050A00	050A00
		292A00,295A00	50.0	45.9	050A00	050A00	050A00	050A00
		295A00,295A00	67.0	61.5	050A00	050A00	050A00	050A00
	MED	292A00	16.5	15.2	-	-	-	-
		295A00	33.5	30.8	047A00	047A00	047A00	050A00
		289A00,295A00	43.5	40.0	050A00	050A00	050A00	050A00
		292A00,295A00	50.0	45.9	050A00	050A00	050A00	050A00
		295A00,295A00	67.0	61.5	050A00	050A00	050A00	050A00
	HIGH	292A00	16.5	15.2	-	-	-	-
		295A00	33.5	30.8	050A00	050A00	050A00	050A00
289A00,295A00		43.5	40.0	050A00	050A00	050A00	050A00	
292A00,295A00		50.0	45.9	050A00	050A00	050A00	050A00	
295A00,295A00		67.0	61.5	050A00	050A00	050A00	050A00	
575-3-60	STD	293A00	16.5	15.2	-	-	-	-
		296A00	33.5	30.8	047A00	047A00	047A00	047A00
		290A00,296A00	43.5	40.0	047A00	050A00	047A00	050A00
		293A00,296A00	50.0	45.9	047A00	047A00	047A00	050A00
		296A00,296A00	67.0	61.5	050A00	050A00	050A00	050A00
	MED	293A00	16.5	15.2	-	-	-	-
		296A00	33.5	30.8	047A00	047A00	047A00	047A00
		290A00,296A00	43.5	40.0	047A00	050A00	047A00	050A00
		293A00,296A00	50.0	45.9	047A00	047A00	047A00	050A00
		296A00,296A00	67.0	61.5	050A00	050A00	050A00	050A00
	HIGH	293A00	16.5	15.2	-	-	-	-
		296A00	33.5	30.8	047A00	047A00	047A00	047A00
290A00,296A00		43.5	40.0	050A00	050A00	050A00	050A00	
293A00,296A00		50.0	45.9	050A00	050A00	050A00	050A00	
296A00,296A00		67.0	61.5	050A00	050A00	050A00	050A00	

LEGEND
APP PWR - 208 / 230V / 460V / 575V
C.O. - Convenience outlet
FLA - Full load amps
IFM - Indoor fan motor
NOM PWR - 240V / 480V / 600V
P.E. - Power exhaust
PWRD - Powered convenience outlet
UNPWRD - Unpowered convenience outlet

ELECTRICAL INFORMATION (UNITS PRODUCED PRIOR TO JULY 30, 2012) cont.

Table 16 – 50TC*A04 UNIT WIRE/FUSE OR HACR BREAKER SIZING DATA SINGLE STAGE COOLING WITH SINGLE SPEED INDOOR FAN MOTOR

NOM. V-PH-Hz.	ELECTRIC HEATER										NO C.O. or UNPWR C.O.										W/PWRD C.O.									
	IFM TYPE	Nom* (kW)	FLA	NO PE.		w/ P.E. (pwrd fr/unit)		NO PE.		w/ P.E. (pwrd fr/unit)		NO PE.		w/ P.E. (pwrd fr/unit)		NO PE.		w/ P.E. (pwrd fr/unit)		NO PE.		w/ P.E. (pwrd fr/unit)								
				MCA	MAX FUSE or HACR BRKR	DISC. SIZE	DISC. SIZE	MCA	MAX FUSE or HACR BRKR	DISC. SIZE	DISC. SIZE	MCA	MAX FUSE or HACR BRKR	DISC. SIZE	DISC. SIZE	MCA	MAX FUSE or HACR BRKR	DISC. SIZE	DISC. SIZE	MCA	MAX FUSE or HACR BRKR	DISC. SIZE	DISC. SIZE							
			FLA	FLA	LRA	FLA	LRA	FLA	LRA	FLA	LRA	FLA	LRA	FLA	LRA	FLA	LRA	FLA	LRA	FLA	LRA	FLA	LRA							
208/ 230-1-60	STD	None	None	27.2	40	26	95	29	97	32	100	32	100	32	100	32	100	32	100	32	100	32	100	32	100					
		3.3/4.4	15.9/18.3	27.2/29.0	40/40	26/27	95/95	29/29	97/97	32/32	100/100	32/32	100/100	32/32	100/100	32/32	100/100	32/32	100/100	32/32	100/100	32/32	100/100	32/32	100/100	32/32	100/100			
		4.9/6.5	23.5/27.1	35.5/40.0	40/45	33/37	95/95	37.9/42.4	45/45	35/39	97/97	41.5/46.0	45/50	38/42	100/100	43.9/48.4	50/50	40/45	102/102	43.9/48.4	50/50	40/45	102/102	43.9/48.4	50/50	40/45	102/102			
		6.5/8.7	31.4/36.3	45.4/51.5	50/60	42/47	95/95	47.8/53.9	50/60	44/50	97/97	51.4/57.5	60/60	47/53	100/100	53.8/59.9	60/60	49/55	102/102	53.8/59.9	60/60	49/55	102/102	53.8/59.9	60/60	49/55	102/102			
		7.9/10.5	37.9/43.8	53.5/60.9	60/70	49/56	95/95	55.9/63.3	70/80	51/58	97/97	59.5/66.9	60/70	55/62	100/100	61.9/69.3	70/70	57/64	102/102	61.9/69.3	70/70	57/64	102/102	61.9/69.3	70/70	57/64	102/102			
	MED	9.8/13.0	46.9/54.2	64.8/73.9	70/80	60/68	95/95	67.1/76.3	70/80	62/70	97/97	70.8/79.9	80/80	65/73	100/100	73.1/82.3	80/80	67/76	102/102	73.1/82.3	80/80	67/76	102/102	73.1/82.3	80/80	67/76	102/102			
		None	None	27.2	40	26	95	29	97	32	100	32	100	32	100	32	100	32	100	32	100	32	100	32	100	32	100			
		3.3/4.4	15.9/18.3	27.2/29.0	40/40	26/27	95/95	29.1/31.4	45/45	29/29	97/97	32.0/35.0	45/45	32/32	100/100	34.4/37.4	50/50	34/34	102/102	34.4/37.4	50/50	34/34	102/102	34.4/37.4	50/50	34/34	102/102			
		4.9/6.5	23.5/27.1	35.5/40.0	40/45	33/37	95/95	37.9/42.4	45/45	35/39	97/97	41.5/46.0	45/50	38/42	100/100	43.9/48.4	50/50	40/45	102/102	43.9/48.4	50/50	40/45	102/102	43.9/48.4	50/50	40/45	102/102			
		6.5/8.7	31.4/36.3	45.4/51.5	50/60	42/47	95/95	47.8/53.9	50/60	44/50	97/97	51.4/57.5	60/60	47/53	100/100	53.8/59.9	60/60	49/55	102/102	53.8/59.9	60/60	49/55	102/102	53.8/59.9	60/60	49/55	102/102			
208/ 230-3-60	STD	None	None	19.4	25	19	89	22	91	25	94	25	94	25	94	25	94	25	94	25	94	25	94	25	94					
		3.3/4.4	9.2/10.6	19.4/19.4	25/25	19/19	89/89	21.3/21.8	30/30	22/22	91/91	24.2/25.4	30/30	25/25	94/94	26.1/27.8	30/30	27/27	96/96	26.1/27.8	30/30	27/27	96/96	26.1/27.8	30/30	27/27	96/96			
		4.9/6.5	13.6/15.6	23.1/25.6	25/30	21/24	89/89	25.5/28.0	30/30	23/26	91/91	29.1/31.6	30/35	27/29	94/94	31.5/34.0	35/35	29/31	96/96	31.5/34.0	35/35	29/31	96/96	31.5/34.0	35/35	29/31	96/96			
		6.5/8.7	18.1/20.9	28.8/32.3	30/35	26/30	89/89	31.1/34.6	35/35	29/32	91/91	34.8/38.3	35/40	32/35	94/94	37.1/40.6	40/45	34/37	96/96	37.1/40.6	40/45	34/37	96/96	37.1/40.6	40/45	34/37	96/96			
		7.9/10.5	21.9/25.3	33.5/37.8	35/40	31/35	89/89	35.9/40.1	40/45	33/37	91/91	39.5/43.8	40/45	36/40	94/94	41.9/46.1	45/50	39/42	96/96	41.9/46.1	45/50	39/42	96/96	41.9/46.1	45/50	39/42	96/96			
	MED	12.0/16.0	33.4/38.5	47.9/54.3	50/60	44/50	89/89	50.3/56.6	60/60	46/52	91/91	53.9/60.3	60/70	50/55	94/94	56.3/62.6	60/70	52/58	96/96	56.3/62.6	60/70	52/58	96/96	56.3/62.6	60/70	52/58	96/96			
		None	None	19.4	25	19	89	21.3	30	22	91	24.2	30	25	94	26.1	30	27	96	26.1	30	27	96	26.1	30	27	96			
		3.3/4.4	9.2/10.6	19.4/19.4	25/25	19/19	89/89	21.3/21.8	30/30	22/22	91/91	24.2/25.4	30/30	25/25	94/94	26.1/27.8	30/30	27/27	96/96	26.1/27.8	30/30	27/27	96/96	26.1/27.8	30/30	27/27	96/96			
		4.9/6.5	13.6/15.6	23.1/25.6	25/30	21/24	89/89	25.5/28.0	30/30	23/26	91/91	29.1/31.6	30/35	27/29	94/94	31.5/34.0	35/35	29/31	96/96	31.5/34.0	35/35	29/31	96/96	31.5/34.0	35/35	29/31	96/96			
		6.5/8.7	18.1/20.9	28.8/32.3	30/35	26/30	89/89	31.1/34.6	35/35	29/32	91/91	34.8/38.3	35/40	32/35	94/94	37.1/40.6	40/45	34/37	96/96	37.1/40.6	40/45	34/37	96/96	37.1/40.6	40/45	34/37	96/96			
460-3-60	HIGH	None	None	19.7	30	20	107	22	109	25	112	25	112	25	112	25	112	25	112	25	112	25	112	25	112					
		3.3/4.4	9.2/10.6	19.7/19.8	30/30	20/20	107/107	21.6/22.1	30/30	22/22	109/109	24.5/25.8	30/30	25/25	112/112	26.4/28.1	30/30	27/27	114/114	26.4/28.1	30/30	27/27	114/114	26.4/28.1	30/30	27/27	114/114			
		4.9/6.5	13.6/15.6	23.5/26.0	30/30	22/24	107/107	25.9/28.4	30/30	24/26	109/109	29.5/32.0	30/35	27/29	112/112	31.9/34.4	35/35	29/32	114/114	31.9/34.4	35/35	29/32	114/114	31.9/34.4	35/35	29/32	114/114			
		6.5/8.7	18.1/20.9	29.1/32.6	30/35	27/30	107/107	31.5/35.0	35/40	29/32	109/109	35.1/38.6	40/40	32/36	112/112	37.5/41.0	40/45	35/38	114/114	37.5/41.0	40/45	35/38	114/114	37.5/41.0	40/45	35/38	114/114			
		7.9/10.5	21.9/25.3	33.9/36.1	35/40	31/35	107/107	36.3/40.5	40/45	33/37	109/109	39.9/44.1	40/45	37/41	112/112	42.3/46.5	45/50	39/43	114/114	42.3/46.5	45/50	39/43	114/114	42.3/46.5	45/50	39/43	114/114			
	STD	12.0/16.0	33.4/38.5	48.3/54.6	50/60	44/50	107/107	50.9/57.0	60/60	47/52	109/109	54.3/60.6	60/70	50/56	112/112	56.6/63.0	60/70	52/58	114/114	56.6/63.0	60/70	52/58	114/114	56.6/63.0	60/70	52/58	114/114			
		None	None	10.2	15	10	46	11.2	15	11	47	12.4	15	13	48	13.4	15	14	49	13.4	15	14	49	13.4	15	14	49			
		6.0	7.2	11.6	15	11	46	12.9	15	12	47	14.4	15	13	48	15.6	20	14	49	15.6	20	14	49	15.6	20	14	49			
		8.8	10.6	15.9	20	15	46	17.1	20	16	47	18.6	20	17	48	19.9	20	18	49	19.9	20	18	49	19.9	20	18	49			
		11.5	13.8	19.9	20	18	46	21.1	25	19	47	22.6	25	21	48	23.9	25	22	49	23.9	25	22	49	23.9	25	22	49			
MED	14.0	16.8	23.6	25	22	46	24.9	25	23	47	26.4	30	24	48	27.6	30	25	49	27.6	30	25	49	27.6	30	25	49				
	None	None	10.2	15	10	46	11.2	15	11	47	12.4	15	13	48	13.4	15	14	49	13.4	15	14	49	13.4	15	14	49				
	6.0	7.2	11.6	15	11	46	12.9	15	12	47	14.4	15	13	48	15.6	20	14	49	15.6	20	14	49	15.6	20	14	49				
	8.8	10.6	15.9	20	15	46	17.1	20	16	47	18.6	20	17	48	19.9	20	18	49	19.9	20	18	49	19.9	20	18	49				
	11.5	13.8	19.9	20	18	46	21.1	25	19	47	22.6	25	21	48	23.9	25	22	49	23.9	25	22	49	23.9	25	22	49				
575-3-60	HIGH	None	None	10.7	15	11	55	11.7	15	12	56	12.9	15	13	57	13.9	20	14	58	13.9	20	14	58	13.9	20	14	58			
		6.0	7.2	12.3	15	11	55	13.5	15	12	56	15.0	15	14	57	16.3	20	15	58	16.3	20	15	58	16.3	20	15	58			
		8.8	10.6	16.5	20	15	55	17.8	20	16	56	19.3	20	18	57	20.5	25	19	58	20.5	25	19	58	20.5	25	19	58			
		11.5	13.8	20.5	25	19	55	21.8	25	20	56	23.3	25	21	57	24.5	25	23	58	24.5	25	23	58	24.5	25	23	58			
		14.0	16.8	24.3	25	22	55	25.5	30	23	56	27.0	30	25	57	28.3	30	26	58	28.3	30	26	58	28.3	30	26	58			
None	None	7.3	15	7	44	9.2	15	9	46	9	15	9	46	10.9	15	11	48	10.9	15	11										

ELECTRICAL INFORMATION (UNITS PRODUCED PRIOR TO JULY 30, 2012) cont.

Table 18 – 50TC*A06 UNIT WIRE/FUSE OR HACR BREAKER SIZING DATA SINGLE STAGE COOLING WITH SINGLE SPEED INDOOR FAN MOTOR

NOM. V-PH-Hz.	IFM TYPE	ELECTRIC HEATER										NO C.O. or UNPWR C.O.										W/PPWR C.O.									
		NO P.E.					w/P.E. (pwrdr fr/unit)					NO P.E.					w/P.E. (pwrdr fr/unit)					NO P.E.					w/P.E. (pwrdr fr/unit)				
		Nom* (kW)	FLA	MCA	MAX FUSE or HACR BRKR	DISC. SIZE FLA LRA	MCA	MAX FUSE or HACR BRKR	DISC. SIZE FLA LRA	MCA	MAX FUSE or HACR BRKR	DISC. SIZE FLA LRA	MCA	MAX FUSE or HACR BRKR	DISC. SIZE FLA LRA	MCA	MAX FUSE or HACR BRKR	DISC. SIZE FLA LRA	MCA	MAX FUSE or HACR BRKR	DISC. SIZE FLA LRA	MCA	MAX FUSE or HACR BRKR	DISC. SIZE FLA LRA	MCA	MAX FUSE or HACR BRKR	DISC. SIZE FLA LRA	MCA	MAX FUSE or HACR BRKR	DISC. SIZE FLA LRA	
208/ 230-1-60	STD	None	None	39.2	60	37	150	150/150	41.1	60	40	152	152/152	44	60	43	155	155/155	45.9	60	45	157	157/157	45.9/48.4	60/60	45/45	157/157	45.9/48.4	60/60	45/45	157/157
		4.9/6.5	23.5/27.1	39.2/40.0	60/60	37/37	150/150	41.1/42.4	60/60	40/40	152/152	44.0/46.0	60/60	43/43	155/155	45.9/48.4	60/60	45/45	157/157	45.9/48.4	60/60	45/45	157/157	45.9/48.4	60/60	45/45	157/157	45.9/48.4	60/60	45/45	157/157
		6.5/8.7	31.4/36.3	45.4/51.5	60/60	42/47	150/150	47.8/53.9	60/60	44/50	152/152	51.4/57.5	60/60	47/53	155/155	53.8/59.9	60/60	49/55	157/157	53.8/59.9	60/60	49/55	157/157	53.8/59.9	60/60	49/55	157/157	53.8/59.9	60/60	49/55	157/157
		9.8/13.0	46.9/54.2	64.8/73.9	70/80	60/68	150/150	67.1/76.3	70/80	62/70	152/152	67.0/79.9	80/80	65/73	155/155	73.1/82.3	80/90	67/76	157/157	73.1/82.3	80/90	67/76	157/157	73.1/82.3	80/90	67/76	157/157	73.1/82.3	80/90	67/76	157/157
		13.1/17.4	62.8/72.5	84.6/96.8	90/100	78/89	150/150	87.0/99.1	90/100	80/91	152/152	90.6/102.8	100/110	83/95	155/155	93.0/105.1	100/110	86/97	157/157	93.0/105.1	100/110	86/97	157/157	93.0/105.1	100/110	86/97	157/157	93.0/105.1	100/110	86/97	157/157
		15.8/21.0	75.8/87.5	100.9/115.5	110/125	93/106	150/150	103.3/117.9	110/125	95/108	152/152	106.9/121.5	110/125	96/112	155/155	109.3/123.9	110/125	98/114	157/157	109.3/123.9	110/125	98/114	157/157	109.3/123.9	110/125	98/114	157/157	109.3/123.9	110/125	98/114	157/157
		None	None	41.3	60	40	175	43.2	60	42	177	46.1	60	45	180	48	60	48	182	48	60	48	182	48	60	48	182	48	60	48	182
		4.9/6.5	23.5/27.1	41.3/42.6	60/60	40/40	175/175	43.2/45.0	60/60	42/42	177/177	46.1/48.6	60/60	45/45	180/180	48.0/51.0	60/60	48/48	182/182	48.0/51.0	60/60	48/48	182/182	48.0/51.0	60/60	48/48	182/182	48.0/51.0	60/60	48/48	182/182
		6.5/8.7	31.4/36.3	48.0/54.1	60/60	44/50	175/175	50.4/56.5	60/60	46/52	177/177	54.0/60.1	60/70	50/55	180/180	56.4/62.5	60/70	52/58	182/182	56.4/62.5	60/70	52/58	182/182	56.4/62.5	60/70	52/58	182/182	56.4/62.5	60/70	52/58	182/182
		9.8/13.0	46.9/54.2	67.4/76.5	70/80	62/70	175/175	69.8/78.9	70/80	64/73	177/177	73.4/82.5	80/90	68/76	180/180	75.8/84.9	80/90	70/78	182/182	75.8/84.9	80/90	70/78	182/182	75.8/84.9	80/90	70/78	182/182	75.8/84.9	80/90	70/78	182/182
13.1/17.4	62.8/72.5	87.3/99.4	90/100	80/91	175/175	89.6/101.8	90/110	82/94	177/177	93.3/105.4	100/110	86/97	180/180	95.6/107.8	100/110	88/99	182/182	95.6/107.8	100/110	88/99	182/182	95.6/107.8	100/110	88/99	182/182	95.6/107.8	100/110	88/99	182/182		
15.8/21.0	75.8/87.5	103.5/118.1	110/125	95/109	175/175	105.9/120.5	110/125	97/111	177/177	109.5/124.1	110/125	98/112	180/180	111.9/126.5	110/125	103/116	182/182	111.9/126.5	110/125	103/116	182/182	111.9/126.5	110/125	103/116	182/182	111.9/126.5	110/125	103/116	182/182		
208/ 230-3-60	STD	None	None	25.9	30	25	126	27.8	40	28	146	30.7	40	31	45	31	149	32.9	45	33	151	33	45	33	151	33	45	33	151		
		4.9/6.5	13.6/15.6	25.9/25.9	30/30	25/25	126/126	27.8/28.0	40/40	28/28	146/146	30.7/31.6	45/45	31/31	149/149	32.9/34.4	45/45	33/33	151/151	32.9/34.4	45/45	33/33	151/151	32.9/34.4	45/45	33/33	151/151	32.9/34.4	45/45	33/33	151/151
		7.9/10.5	21.9/25.3	33.5/37.8	40/40	31/35	126/126	35.9/40.1	40/45	33/37	128/128	39.5/43.8	45/45	36/40	131/131	41.9/46.1	45/50	39/42	133/133	41.9/46.1	45/50	39/42	133/133	41.9/46.1	45/50	39/42	133/133	41.9/46.1	45/50	39/42	133/133
		12.0/16.0	33.4/38.5	47.9/54.3	50/60	44/50	126/126	50.3/56.6	60/60	46/52	128/128	53.9/60.3	60/70	50/55	131/131	56.3/62.6	60/70	52/58	133/133	56.3/62.6	60/70	52/58	133/133	56.3/62.6	60/70	52/58	133/133	56.3/62.6	60/70	52/58	133/133
		15.8/21.0	43.8/50.5	60.9/69.3	70/70	56/64	126/126	63.3/71.6	70/80	58/66	128/128	66.9/75.3	70/80	62/70	131/131	69.3/77.6	70/80	64/71	133/133	69.3/77.6	70/80	64/71	133/133	69.3/77.6	70/80	64/71	133/133	69.3/77.6	70/80	64/71	133/133
		19.9/26.5	55.2/63.8	75.5/86.3	80/90	69/79	144/144	77.9/88.3	80/90	67/79	146/146	81.3/92.3	90/100	75/85	151/151	83.5/94.3	90/100	77/87	153/133	83.5/94.3	90/100	77/87	153/133	83.5/94.3	90/100	77/87	153/133	83.5/94.3	90/100	77/87	153/133
		None	None	26.2	40	26	144	28.1	40	28	146	31	149	32.9	45	33	151	33	151	32.9	45	33	151	33	151	32.9	45	33	151	33	151
		4.9/6.5	13.6/15.6	26.2/26.2	40/40	26/26	144/144	28.1/28.4	40/40	26/26	146/146	31.0/32.0	45/45	31/31	149/149	32.9/34.4	45/45	33/33	151/151	32.9/34.4	45/45	33/33	151/151	32.9/34.4	45/45	33/33	151/151	32.9/34.4	45/45	33/33	151/151
		7.9/10.5	21.9/25.3	33.9/38.1	40/40	31/35	144/144	36.3/40.5	40/45	33/37	146/146	39.9/44.1	45/45	37/41	149/149	42.3/46.5	45/50	39/43	151/151	42.3/46.5	45/50	39/43	151/151	42.3/46.5	45/50	39/43	151/151	42.3/46.5	45/50	39/43	151/151
		12.0/16.0	33.4/38.5	48.3/54.6	50/60	44/50	144/144	50.6/57.0	60/60	47/52	146/146	54.3/60.6	60/70	50/56	149/149	56.6/63.0	60/70	52/58	151/151	56.6/63.0	60/70	52/58	151/151	56.6/63.0	60/70	52/58	151/151	56.6/63.0	60/70	52/58	151/151
15.8/21.0	43.8/50.5	61.3/69.6	70/70	56/64	144/144	63.6/72.0	70/80	59/66	146/146	67.3/75.6	70/80	62/70	149/149	69.6/78.0	70/80	64/72	151/151	69.6/78.0	70/80	64/72	151/151	69.6/78.0	70/80	64/72	151/151	69.6/78.0	70/80	64/72	151/151		
19.9/26.5	55.2/63.8	75.5/86.3	80/90	69/79	144/144	77.9/88.6	80/90	69/79	146/146	81.3/92.3	90/100	75/85	151/151	83.5/94.3	90/100	77/87	153/133	83.5/94.3	90/100	77/87	153/133	83.5/94.3	90/100	77/87	153/133	83.5/94.3	90/100	77/87	153/133		
460-3-60	HIGH	None	None	28.5	40	28	170	30.4	45	30	172	33.3	45	34	175	35.2	50	36	177	35.2	50	36	177	35.2	50	36	177	35.2	50	36	177
		4.9/6.5	13.6/15.6	28.5/28.9	40/40	28/28	170/170	30.4/31.3	45/45	30/30	172/172	33.3/34.9	45/45	34/34	175/175	35.2/37.3	50/50	36/36	177/177	35.2/37.3	50/50	36/36	177/177	35.2/37.3	50/50	36/36	177/177	35.2/37.3	50/50	36/36	177/177
		7.9/10.5	21.9/25.3	36.8/41.0	40/45	34/38	170/170	38.1/43.4	45/45	36/40	172/172	42.8/47.0	45/50	39/43	175/175	45.1/49.4	50/50	42/45	177/177	45.1/49.4	50/50	42/45	177/177	45.1/49.4	50/50	42/45	177/177	45.1/49.4	50/50	42/45	177/177
		12.0/16.0	33.4/38.5	51.1/57.5	60/60	47/53	170/170	53.5/59.9	60/70	49/55	172/172	57.1/63.5	60/70	53/58	175/175	59.5/65.9	60/70	55/61	177/177	59.5/65.9	60/70	55/61	177/177	59.5/65.9	60/70	55/61	177/177	59.5/65.9	60/70	55/61	177/177
		15.8/21.0	43.8/50.5	64.1/72.5	70/80	59/67	170/170	66.5/74.9	70/80	61/69	172/172	70.1/78.5	80/80	65/72	175/175	72.5/80.9	80/90	67/74	177/177	72.5/80.9	80/90	67/74	177/177	72.5/80.9	80/90	67/74	177/177	72.5/80.9	80/90	67/74	177/177
		19.9/26.5	55.2/63.8	78.4/89.1	80/90	72/82	170/170	80.8/91.5	90/100	74/84	172/172	84.4/95.1	90/100	78/88	175/175	86.8/97.5	90/100	80/90	177/177	86.8/97.5	90/100	80/90	177/177	86.8/97.5	90/100	80/90	177/177	86.8/97.5	90/100	80/90	177/177
		None	None	12.5	20	12	60	13.5	20	13	61	14.7	20	15	62	15.7	20	16	63	15.7	20	16	63	15.7	20	16	63	15.7	20	16	63
		6.0	7.2	12.5	20	12	60	13.5	20	13	61	14.7	20	15	62	15.7	20	16	63												

ELECTRICAL INFORMATION (UNITS PRODUCED PRIOR TO JULY 30, 2012) cont.
UNIT WIRE/FUSE OR HACR BREAKER SIZING DATA 2-STAGE COOLING WITH SINGLE SPEED INDOOR FAN MOTOR

Table 21 – 50TC*D08

NOM. V- Φ -Hz.	ELECTRIC HEATER										NO C.O. or UNPWR C.O.										W/PWR C.O.									
	IFM TYPE	Nom* (kW)	FLA	NO PE.			w/ P.E. (pwrld fr/unit)			NO PE.			w/ P.E. (pwrld fr/unit)			NO PE.			w/ P.E. (pwrld fr/unit)											
				MCA	MAX FUSE or HACR BRKR	DISC. SIZE FLA	DISC. SIZE LRA	MCA	MAX FUSE or HACR BRKR	DISC. SIZE FLA	DISC. SIZE LRA	MCA	MAX FUSE or HACR BRKR	DISC. SIZE FLA	DISC. SIZE LRA	MCA	MAX FUSE or HACR BRKR	DISC. SIZE FLA	DISC. SIZE LRA											
208/ 230-3-60	STD	7.8/10.4	-	21.7/25.0	41	193	42.6	50	45	197	43.6	50	46	198	47.4	60	51	202	60/60	51/51	202/202									
		12.0/16.0	38.8/38.8	41/41	193/193	42.6/42.6	50/50	45/45	197/197	43.6/43.6	50/50	46/46	198/198	47.4/48.5	60/60	51/51	202/202	60/60	51/51	202/202										
		18.6/24.8	48.3/54.6	44/50	193/193	53.0/59.4	60/60	49/55	197/197	54.3/60.6	60/70	50/56	198/198	59.0/65.4	60/70	54/60	202/202	60/70	54/60	202/202										
		24.0/32.0	71.1/81.1	66/75	193/193	75.9/85.9	80/90	70/79	197/197	77.1/87.1	80/90	71/80	198/198	81.9/91.9	80/100	75/85	202/202	90/100	75/85	202/202										
		31.8/42.4	89.9/102.8	83/95	193/193	94.6/107.5	100/110	87/99	197/197	95.9/108.8	100/110	88/100	198/198	100.6/113.5	100/110	93/104	202/202	110/125	93/104	202/202										
	MED	7.8/10.4	41.1	21.7/25.0	43	230	44.9	50	48	234	45.9	50	49	235	49.7	60	53	239	60/60	53/53	239/239									
		12.0/16.0	51.1/57.5	47/53	230/230	55.9/62.3	60/70	51/57	234/234	57.1/63.5	60/70	53/58	235/235	61.9/68.3	70/70	57/63	239/239	70/70	57/63	239/239										
		18.6/24.8	74.0/84.0	68/77	230/230	78.8/88.8	80/90	72/82	234/234	80.0/90.0	90/100	74/83	235/235	84.8/94.8	90/100	78/87	239/239	90/100	78/87	239/239										
		24.0/32.0	92.8/105.6	85/97	230/230	97.5/110.4	100/125	90/102	234/234	98.8/111.6	100/125	91/103	235/235	103.5/116.4	110/125	95/107	239/239	110/125	95/107	239/239										
		31.8/42.4	119.9/136.9	110/126	230/230	124.6/141.6	125/150	115/130	234/234	125.9/142.9	150/175	116/131	235/235	130.6/147.6	150/150	120/136	239/239	150/150	120/136	239/239										
460-3-60	STD	7.8/10.4	49.0	21.7/25.0	52	256	52.8	60	56	260	53.8	60	58	261	57.6	70	62	265	70/70	62/62	265/265									
		12.0/16.0	63.4/69.9	56/62	256/256	65.3/71.6	70/80	60/66	260/260	66.5/72.9	70/80	61/67	261/261	71.3/77.6	80/80	66/71	265/265	80/80	66/71	265/265										
		18.6/24.8	83.4/93.4	77/86	256/256	88.1/98.1	90/100	81/90	260/260	89.4/99.4	90/100	82/91	261/261	94.1/104.1	100/110	87/96	265/265	100/110	87/96	265/265										
		24.0/32.0	102.1/115.0	94/106	256/256	106.9/119.8	110/125	100/110	260/260	108.1/121.0	110/125	99/111	261/261	112.9/125.8	125/150	104/116	265/265	125/150	104/116	265/265										
		31.8/42.4	129.3/146.3	119/135	256/256	134.0/151.0	150/175	123/139	260/260	135.3/152.3	150/175	124/140	261/261	140.0/157.0	150/175	129/144	265/265	150/175	129/144	265/265										
	HIGH	13.9	17.9	16.7	19	95	19.7	25	21	97	20.1	25	21	97	21.9	25	23	99	30	27	99									
		16.5	24.1	19.8	22	95	26.4	30	24	97	26.9	30	25	97	28.1	30	27	99	30	27	99									
		27.8	28.0	33.4	26	95	30.3	35	28	97	30.8	35	28	97	33.0	35	30	99	30	27	99									
		33.0	45.0	39.7	41	95	47.3	50	43	97	47.8	50	44	97	50.0	60	46	99	60	46	99									
		41.7	52.9	50.2	49	95	55.1	60	51	97	55.6	60	51	97	57.9	60	53	99	60	53	99									
575-3-60	STD	7.8/10.4	18.7	21.7/25.0	20	114	20.5	25	116	20.9	25	22	116	22.7	25	24	118	25	24	118										
		12.0/16.0	24.1	19.8	22	114	27.4	30	25	116	27.9	30	26	116	30.1	35	28	118	35	28	118									
		18.6/24.8	29.0	33.4	27	114	31.3	35	29	116	31.8	35	29	116	34.0	35	31	118	35	31	118									
		24.0/32.0	46.0	39.7	42	114	48.3	50	44	116	48.8	50	45	116	51.0	60	47	118	60	47	118									
		31.8/42.4	53.9	39.7	50	114	56.1	60	52	116	56.6	60	52	116	58.9	60	54	118	60	54	118									
	MED	13.9	17.9	16.7	20	114	19.7	25	22	116	20.9	25	22	116	22.7	25	24	118	25	24	118									
		16.5	24.1	19.8	23	114	27.4	30	25	116	27.9	30	26	116	30.1	35	28	118	35	28	118									
		27.8	28.0	33.4	27	114	31.3	35	29	116	31.8	35	29	116	34.0	35	31	118	35	31	118									
		33.0	46.0	39.7	42	114	48.3	50	44	116	48.8	50	45	116	51.0	60	47	118	60	47	118									
		41.7	53.9	50.2	50	114	56.1	60	52	116	56.6	60	52	116	58.9	60	54	118	60	54	118									

* Nominal values, listed as 208/240V, 460V or 600V as appropriate.

ELECTRICAL INFORMATION (UNITS PRODUCED PRIOR TO JULY 30, 2012) cont.

Table 22 – 50TC*D08 UNIT WIRE/FUSE OR HACR BREAKER SIZING DATA 2-STAGE COOLING WITH 2 SPEED INDOOR FAN MOTOR

NOM. V-PH-Hz.	ELECTRIC HEATER										NO C.O. or UNPWR C.O.										w/ PWRD C.O.													
	IFM TYPE	Nom (kW)	FLA	NO PE.			w/ P.E. (pwrd fr/unit)			NO PE.			w/ P.E. (pwrd fr/unit)			NO PE.			w/ P.E. (pwrd fr/unit)			NO PE.			w/ P.E. (pwrd fr/unit)									
				MAX FUSE or HACR BRKR	MCA	DISC. SIZE FLA LRA	MCA	DISC. SIZE FLA LRA	MCA	DISC. SIZE FLA LRA	MAX FUSE or HACR BRKR	MCA	DISC. SIZE FLA LRA	MAX FUSE or HACR BRKR	MCA	DISC. SIZE FLA LRA	MAX FUSE or HACR BRKR	MCA	DISC. SIZE FLA LRA	MAX FUSE or HACR BRKR	MCA	DISC. SIZE FLA LRA	MAX FUSE or HACR BRKR	MCA	DISC. SIZE FLA LRA									
208/ 230-3-60	STD	-	-	39.4/39.2	41/41	197	43.2/43.0	50/50	46/46	201	44.2/44.0	50/50	47/47	202	48.0/47.8	60/60	51/51	206/206	7.8/10.4	21.7/25.0	41/41	197/197	43.2/43.0	50/50	46/46	201/201	44.2/44.0	50/50	47/47	202/202	48.0/49.0	60/60	51/51	206/206
		7.8/10.4	21.7/25.0	39.4/39.2	41/41	197/197	43.2/43.0	50/50	46/46	201/201	44.2/44.0	50/50	47/47	202/202	48.0/49.0	60/60	51/51	206/206	12.0/16.0	33.4/38.5	45/51	197/197	53.8/59.9	60/60	49/55	201/201	55.0/61.1	60/70	55/61	206/206				
		18.6/24.8	51.7/59.7	71.9/81.6	66/75	197/197	76.6/86.4	80/90	70/79	201/201	77.9/87.6	80/90	72/81	202/202	82.6/92.4	90/100	76/85	206/206	24.0/32.0	66.7/77.0	83/95	197/197	95.4/108.0	100/110	88/99	201/201	96.6/109.3	100/110	89/101	202/202	101.4/114.0	110/125	93/105	206/206
		31.8/42.4	88.4/102.0	117.8/134.5	108/124	197/197	122.5/139.3	125/150	113/128	201/201	123.8/140.5	125/150	114/129	202/202	128.5/145.3	150/150	118/134	206/206	31.8/42.4	88.4/102.0	112/126	227/227	126.0/142.0	150/150	116/131	231/231	127.3/143.3	150/150	117/132	232/232	132.0/148.0	150/150	121/136	236/236
		47.2/46.3	47.2/47.1	47.2/46.3	50/49	262	51.0/50.1	60/60	55/54	266	52.0/51.1	60/60	56/55	267	55.8/54.9	60/60	60/59	271	7.8/10.4	21.7/25.0	50/49	227/227	46.0/45.8	50/50	49/48	231/231	47.0/47.0	60/60	55/54	236/236				
	7.8/10.4	21.7/25.0	47.2/47.1	50/49	262/262	51.0/51.9	60/60	55/54	266/266	52.0/53.1	60/60	56/55	267/267	55.8/57.9	60/60	60/59	271/271	12.0/16.0	33.4/38.5	48/53	227/227	57.3/62.6	60/70	53/58	231/231	58.5/63.9	60/70	54/59	232/232	63.3/68.6	70/70	58/63	236/236	
	18.6/24.8	51.7/59.7	75.4/84.4	69/78	227/227	80.1/89.1	90/90	74/82	231/231	81.4/90.4	90/100	75/83	232/232	86.1/95.1	90/100	79/88	236/236	24.0/32.0	66.7/77.0	87/98	227/227	98.9/110.8	100/125	91/102	231/231	100.1/112.0	110/125	92/103	232/232	104.9/116.8	110/125	96/107	236/236	
	31.8/42.4	88.4/102.0	121.3/137.3	112/126	227/227	126.0/142.0	150/150	116/131	231/231	127.3/143.3	150/150	117/132	232/232	132.0/148.0	150/150	123/137	236/236	31.8/42.4	88.4/102.0	117/132	262/262	132.3/148.1	150/150	122/136	266/266	133.5/149.4	150/150	123/137	267/267	138.3/154.1	150/175	127/142	271/271	
	18.2	19	97	20.0	25	20.0	25	21	99	20.4	25	22	99	22.2	25	24	101	13.9	16.7	23	97	26.8	30	25	99	27.3	30	25	99	29.5	30	27	101	
	24.5	23	97	26.8	30	26.8	30	25	99	27.3	30	25	99	29.5	30	27	101	16.5	19.8	26	97	30.6	35	28	99	31.1	35	29	99	33.4	35	31	101	
28.4	26	97	30.6	35	30.6	35	28	99	31.1	35	28	99	33.4	35	31	101	27.8	33.4	42	97	47.6	50	44	99	48.1	50	44	99	50.4	50	46	101		
45.4	42	97	47.6	50	47.6	50	44	99	48.1	50	44	99	50.4	50	46	101	33.0	39.7	49	97	55.5	60	51	99	56.0	60	52	99	58.3	60	54	101		
53.3	49	97	55.5	60	55.5	60	51	99	56.0	60	52	99	58.3	60	54	101	41.7	50.2	61	97	66.4	70	63	99	69.1	70	64	99	71.4	80	66	101		
66.4	61	97	66.4	70	66.4	70	63	99	69.1	70	64	99	71.4	80	66	101	13.9	16.7	20	113	20.9	25	22	115	21.3	25	23	115	23.1	25	25	117		
19.1	20	113	20.9	25	20.9	25	22	115	21.3	25	23	115	23.1	25	25	117	16.5	19.8	24	113	27.9	30	26	115	28.4	30	26	115	30.6	35	28	117		
25.6	24	113	27.9	30	27.9	30	26	115	28.4	30	26	115	30.6	35	31	101	16.5	19.8	27	113	31.8	35	30	115	32.3	35	30	115	34.5	35	32	117		
29.5	27	113	31.8	35	31.8	35	29	115	32.3	35	30	115	34.5	35	31	101	27.8	33.4	43	113	48.8	50	45	115	49.3	50	45	115	51.5	60	47	117		
46.5	43	113	48.8	50	48.8	50	45	115	49.3	50	45	115	51.5	60	50	101	33.0	39.7	50	113	56.6	60	52	115	57.1	60	53	115	59.4	60	55	117		
54.4	50	113	56.6	60	56.6	60	52	115	57.1	60	53	115	59.4	60	55	117	41.7	50.2	62	113	69.8	70	64	115	70.3	80	65	115	72.5	80	67	117		
67.5	62	113	69.8	70	69.8	70	64	115	70.3	80	65	115	72.5	80	67	117	13.9	16.7	23	130	23.6	30	26	132	24.0	30	26	132	25.8	30	28	134		
21.8	20	130	23.6	30	23.6	30	25	132	24.0	30	26	132	25.8	30	28	134	13.9	16.7	27	130	31.1	35	29	132	31.6	35	29	132	33.9	35	31	134		
28.9	27	130	31.1	35	31.1	35	29	132	31.6	35	29	132	33.9	35	31	134	16.5	19.8	30	130	35.0	40	33	132	35.5	40	33	132	37.8	40	35	134		
32.8	30	130	35.0	40	35.0	40	32	132	35.5	40	33	132	37.8	40	35	134	27.8	33.4	46	130	52.0	60	48	132	52.5	60	48	132	54.8	60	50	134		
49.8	46	130	52.0	60	52.0	60	48	132	52.5	60	48	132	54.8	60	50	134	33.0	39.7	53	130	59.9	70	56	132	60.4	70	56	132	62.6	70	58	134		
57.6	53	130	59.9	70	59.9	70	55	132	60.4	70	56	132	62.6	70	58	134	41.7	50.2	65	130	73.0	80	68	132	73.5	80	68	132	75.8	80	70	134		
70.8	65	130	73.0	80	73.0	80	67	132	73.5	80	68	132	75.8	80	70	134	13.9	16.7	14	79	17.3	20	16	83	15.2	20	16	81	19.0	25	21	85		
13.5	15	79	17.3	20	17.3	20	14	79	17.3	20	16	83	15.2	20	16	81	17.0	20.4	27	79	33.8	35	31	83	31.1	35	29	81	35.9	40	33	85		
29.0	30	79	33.8	35	33.8	35	27	79	33.8	35	31	83	31.1	35	29	81	34.0	40.9	50	79	59.4	60	55	83	56.8	60	52	81	61.5	70	57	85		
54.6	60	79	59.4	60	59.4	60	50	79	59.4	60	55	83	56.8	60	52	81	17.0	20.4	16	92	19.0	25	21	96	16.9	20	18	94	20.7	25	23	98		
15.2	20	92	19.0	25	19.0	25	16	92	19.0	25	16	92	16.9	20	18	94	17.0	20.4	29	92	35.9	40	33	96	33.3	35	31	94	38.0	40	35	98		
31.1	35	92	35.9	40	35.9	40	29	94	33.3	35	31	96	33.3	35	31	94	34.0	40.9	52	92	61.5	70	57	96	58.9	60	54	94	63.6	70	59	98		
56.8	60	92	61.5	70	61.5	70	52	92	61.5	70	57	96	58.9	60	54	94	17.0	20.4	18	106	21.2	25	20	110	19.1	25	20	108	22.9	25	24	112		
17.4	20	106	21.2	25	21.2	25	18	106	21.2	25	18	106	19.1	25	20	110	17.0	20.4	31	106	38.0	40	35	110	35.4	40	33	108	40.1	45	37	112		
33.3	35	106	38.0	40	38.0	40	31	106	38.0	40	35	110	35.4	40	33	108	34.0	40.9	54	106	63.6	70	59	110	61.0	70	56	108	65.8	70	60	112		
58.9	60	106	63.6	70	63.6	70	54	106	63.6	70	59	110	61.0	70	56	108	17.0	20.4	40.9	106	58.9	60	54	110	58.9	60	54	108	65.8	70	60	112		

* Nominal values, listed as 208/240V, 480V or 600V as appropriate.

ELECTRICAL INFORMATION (UNITS PRODUCED PRIOR TO JULY 30, 2012) cont.

Table 25 – 50TC*D09 UNIT WIRE/FUSE OR HACR BREAKER SIZING DATA 2-STAGE COOLING WITH 2 SPEED INDOOR FAN MOTOR

NOM V- PH-Hz.	ELECTRIC HEATER				NO C.O. or UNPWR C.O.				NO P.E.				w/ PWRD C.O.						
	IFM TYPE	Nom (kW)	FLA	MCA	MAX FUSE or HACR BRKR	DISC. SIZE		MCA	MAX FUSE or HACR BRKR	MCA	DISC. SIZE		MAX FUSE or HACR BRKR	MCA	DISC. SIZE		MAX FUSE or HACR BRKR		
						FLA	LRA				FLA	LRA			FLA	LRA		FLA	LRA
208/ 230-3-60	STD	7.8/10.4	21.7/25.0	40.6/40.4	50/50	43/42	212	44.4/44.2	50/50	47/47	216	45.4/45.2	50/50	48/48	217	49.2/49.0	60/60	52/52	221
		12.0/16.0	33.4/38.5	49.0/55.1	50/60	43/42	212/212	44.4/44.2	50/50	47/47	216/216	45.4/45.2	50/50	48/48	217/217	49.2/49.0	60/60	52/52	221/221
		18.6/24.8	51.7/59.7	71.9/81.6	80/90	66/75	212/212	53.8/59.9	60/60	49/55	216/216	55.0/61.1	60/70	51/56	217/217	59.8/65.9	90/100	55/61	221/221
		24.0/32.0	66.7/77.0	90.6/103.3	100/110	83/95	212/212	76.6/86.4	80/90	70/79	216/216	77.9/87.6	80/90	72/81	217/217	82.6/92.4	90/100	76/85	221/221
		31.8/42.4	88.4/102.0	117.8/134.5	125/150	108/124	212/212	95.4/108.0	100/110	88/99	216/216	96.6/109.3	100/110	89/101	217/217	101.4/114.0	110/125	93/105	221/221
		7.8/10.4	21.7/25.0	41.9/41.6	50/50	44/44	216	45.7/45.4	60/60	48/48	220	46.7/46.4	60/60	50/49	221	50.5/50.2	60/60	54/54	225
		12.0/16.0	33.4/38.5	50.6/56.6	60/60	47/52	216/216	45.7/45.4	60/50	48/48	220/220	46.7/46.4	60/60	50/49	221/221	50.5/50.5	60/60	54/54	225/225
		18.6/24.8	51.7/59.7	73.5/83.1	80/90	68/76	216/216	55.4/61.4	60/70	51/56	220/220	56.6/62.6	60/70	52/58	221/221	61.4/67.4	70/70	56/62	225/225
		24.0/32.0	66.7/77.0	92.3/104.8	100/110	85/96	216/216	78.3/87.9	80/90	72/81	220/220	79.5/89.1	80/90	73/82	221/221	84.3/93.9	90/100	78/86	225/225
		31.8/42.4	88.4/102.0	119.4/136.0	125/150	110/125	216/216	97.0/109.5	100/110	89/101	220/220	98.3/110.8	100/125	90/102	221/221	103.0/115.5	110/125	95/106	225/225
460-3-60	HIGH	7.8/10.4	21.7/25.0	45.6/44.6	60/50	48/47	266	49.4/48.4	60/60	53/52	270	50.4/49.4	60/60	54/53	271	54.2/53.2	60/60	58/57	275
		12.0/16.0	33.4/38.5	55.3/60.4	60/70	51/56	266/266	49.4/48.4	60/60	53/52	270/270	50.4/49.5	60/60	54/53	271/271	54.2/54.3	60/60	58/57	275/275
		18.6/24.8	51.7/59.7	78.1/86.9	80/90	72/80	266/266	60.0/65.1	60/70	55/60	270/270	61.3/66.4	70/70	56/61	271/271	66.0/71.1	70/80	61/65	275/275
		24.0/32.0	66.7/77.0	96.9/108.5	100/110	89/100	266/266	82.9/91.6	90/100	76/84	270/270	84.1/92.9	90/100	77/85	271/271	88.9/97.6	90/100	82/90	275/275
		31.8/42.4	88.4/102.0	124.0/139.8	125/150	114/129	266/266	101.6/113.3	110/125	93/104	270/270	102.9/114.5	110/125	95/105	271/271	107.6/119.3	110/125	99/110	275/275
		13.9	16.7	24.5	25	20	111	20.4	25	22	113	20.8	25	22	113	22.6	25	24	115
		16.5	19.8	28.4	30	23	111	26.8	30	25	113	27.3	30	25	113	29.5	30	27	115
		27.8	33.4	45.4	50	42	111	30.6	35	28	113	31.1	35	29	113	33.4	35	31	115
		33.0	39.7	53.3	60	49	111	47.6	50	44	113	48.1	50	44	113	50.4	60	46	115
		41.7	50.2	66.4	70	61	111	55.5	60	51	113	56.0	60	52	113	58.3	60	54	115
575-3-60	STD	13.9	16.7	25.6	30	24	21.3	25	23	116	21.7	25	23	116	23.5	30	25	118	
		16.5	19.8	29.5	30	27	114	27.9	30	26	116	28.4	30	26	116	30.6	35	28	118
		27.8	33.4	46.5	50	43	114	31.8	35	29	116	32.3	35	30	116	34.5	35	32	118
		33.0	39.7	54.4	60	51	114	48.8	50	45	116	49.3	50	45	116	51.5	60	47	118
		41.7	50.2	67.5	70	62	114	56.6	60	52	116	57.1	60	53	116	59.4	60	55	118
		13.9	16.7	20.6	25	20	139	22.4	25	24	141	22.8	25	24	141	24.6	30	26	143
		16.5	19.8	30.9	30	25	139	29.3	30	27	141	29.8	30	27	141	32.0	35	29	143
		27.8	33.4	47.9	50	44	139	33.1	35	30	141	33.6	35	31	141	35.9	40	33	143
		33.0	39.7	55.8	60	51	139	50.1	60	46	141	50.6	60	47	141	52.9	60	49	143
		41.7	50.2	68.9	70	63	139	58.0	60	53	141	58.5	60	54	141	60.8	70	56	143
575-3-60	MED	17.0	20.4	29.0	30	27	16.3	20	17	87	20.1	25	21	89	21.8	25	23	93	
		34.0	40.9	54.6	60	50	87	33.8	35	31	91	31.1	35	29	89	35.9	40	33	93
		17.0	20.4	29.9	30	27	91	34.6	35	32	95	32.0	35	29	93	36.8	40	34	97
		34.0	40.9	55.5	60	51	91	60.3	70	55	95	57.6	60	53	93	62.4	70	57	97
		17.0	20.4	18.0	20	19	100	21.8	25	20	104	19.7	25	21	102	23.5	30	25	106
		34.0	40.9	56.8	60	52	100	61.5	70	57	104	58.9	60	54	102	63.6	70	59	106

* Nominal values, listed as 208/240V, 480V or 600V as appropriate.

ELECTRICAL INFORMATION (UNITS PRODUCED PRIOR TO JULY 30, 2012) cont.

Table 26 – 50TC*A12 UNIT WIRE/FUSE OR HACR BREAKER SIZING DATA SINGLE STAGE COOLING WITH SINGLE SPEED INDOOR FAN MOTOR

NOM. V-PH-Hz.	ELECTRIC HEATER										NO C.O. or UNPWR C.O.										W/PWR C.O.									
	IFM TYPE	Nom* (kW)	FLA	NO PE.			w/ P.E. (pwrd fr/unit)			NO PE.			w/ P.E. (pwrd fr/unit)			NO PE.			w/ P.E. (pwrd fr/unit)											
				MCA	MAX FUSE or HACR BRKR	DISC. SIZE	MCA	MAX FUSE or HACR BRKR	DISC. SIZE	MCA	MAX FUSE or HACR BRKR	DISC. SIZE	MCA	MAX FUSE or HACR BRKR	DISC. SIZE	MCA	MAX FUSE or HACR BRKR	DISC. SIZE	MCA	MAX FUSE or HACR BRKR	DISC. SIZE									
			FLA	FLA	LRA	FLA	FLA	LRA	FLA	FLA	LRA	FLA	FLA	LRA	FLA	FLA	LRA	FLA	FLA	LRA										
208/ 230-3-60	STD	None	None	45.8	60	44	263	49.6	60	48	267	50.6	60	50	268	54.4	80	54	272	272/272										
		7.8/10.4	21.7/25.0	45.8/45.8	60/60	44/44	263/263	49.6/49.6	60/60	48/48	267/267	50.6/50.6	60/60	50/50	268/268	54.4/54.4	80/80	54/54	272/272	272/272										
		12.0/16.0	33.4/38.5	48.3/54.6	60/60	44/50	263/263	53.0/59.4	60/60	49/55	267/267	50.6/60.6	60/60	50/56	268/268	59.0/65.4	80/80	54/60	272/272	272/272										
		24.0/32.0	66.7/77.0	89.9/102.8	90/110	83/95	263/263	94.6/107.5	100/110	87/99	267/267	95.9/108.8	100/110	88/100	268/268	100.6/113.5	110/125	93/104	272/272	272/272										
		31.8/42.4	88.4/102.0	117.0/134.0	125/150	108/123	263/263	121.8/138.8	125/150	112/128	267/267	123.0/140.0	125/150	113/129	268/268	127.8/144.8	150/150	118/133	272/272	272/272										
		37.6/50.0	104.2/120.3	136.8/126.8	150/150	126/144	263/263	141.5/131.6	150/150	130/149	267/267	142.8/132.8	150/150	131/150	268/268	147.5/137.6	150/150	136/154	272/272	272/272										
		None	None	50.6	60	306	54.4	80	310	54	310	55.4	80	55	311	59.2	80	59	315	315	315									
		7.8/10.4	21.7/25.0	50.6/50.6	60/60	50/50	306/306	54.4/54.4	80/80	54/54	310/310	55.4/55.4	80/80	55/55	311/311	59.2/59.2	80/80	59/59	315/315	315/315										
		12.0/16.0	33.4/38.5	54.3/60.6	60/80	50/56	306/306	59.0/65.4	80/80	54/60	310/310	60.3/66.6	80/80	55/61	311/311	65.0/71.4	80/80	60/66	315/315	315/315										
		24.0/32.0	66.7/77.0	95.9/108.8	100/110	88/100	306/306	100.6/113.5	110/125	93/104	310/310	101.9/114.8	110/125	94/106	311/311	106.6/119.5	110/125	98/110	315/315	315/315										
31.8/42.4	88.4/102.0	123.0/140.0	125/150	113/129	306/306	127.8/144.8	150/150	118/133	310/310	129.0/146.0	150/150	119/134	311/311	133.8/150.8	150/175	123/139	315/315	315/315												
37.6/50.0	104.2/120.3	142.8/132.8	150/150	131/150	306/306	147.5/137.6	150/150	136/154	310/310	148.8/138.8	150/150	137/155	311/311	153.5/143.6	175/175	141/160	315/315	315/315												
460-3-60	STD	None	None	25.1	30	24	133	26.9	40	26	135	27.3	40	27	135	29.1	45	29	137	137										
		13.9	16.7	25.1	30	24	133	26.9	40	26	135	27.3	40	27	135	29.1	45	29	137	137										
		16.5	19.8	28.0	30	26	133	30.3	40	28	135	30.8	40	28	135	33.0	45	30	137	137										
		33.0	39.7	52.9	60	49	133	55.1	60	51	135	55.6	60	51	135	57.9	60	53	137	137										
		41.7	50.2	66.0	70	61	133	66.3	70	63	135	68.8	70	63	135	71.0	80	65	137	137										
		50.0	60.1	63.4	70	72	133	65.6	70	74	135	66.1	70	75	135	68.4	70	77	137	137										
		None	None	26.9	40	26	155	28.7	45	28	157	29.1	45	29	157	30.9	45	31	159	159										
		13.9	16.7	26.9	40	26	155	28.7	45	28	157	29.1	45	29	157	31.4	45	31	159	159										
		16.5	19.8	30.3	40	28	155	32.5	45	30	157	33.0	45	30	157	35.3	45	32	159	159										
		33.0	39.7	55.1	60	51	155	57.4	60	53	157	57.9	60	53	157	60.1	70	55	159	159										
41.7	50.2	68.3	70	63	155	70.5	80	65	157	71.0	80	65	157	73.3	80	67	159	159												
50.0	60.1	65.6	80	74	155	67.9	80	76	157	68.4	80	77	157	70.6	80	79	159	159												
575-3-60	STD	None	None	29.9	45	30	159	31.7	45	32	161	32.1	45	32	161	33.9	50	34	163	163										
		13.9	16.7	30.1	45	30	159	32.4	45	32	161	32.9	45	32	161	35.1	50	34	163	163										
		16.5	19.8	34.0	45	31	159	36.3	45	33	161	36.8	45	34	161	39.0	50	36	163	163										
		33.0	39.7	58.9	60	54	159	61.1	70	56	161	61.6	70	57	161	63.9	70	59	163	163										
		41.7	50.2	72.0	80	66	159	74.3	80	68	161	74.8	80	69	161	77.0	80	71	163	163										
		50.0	60.1	69.4	80	78	159	71.6	80	80	161	72.1	80	80	161	74.4	80	82	163	163										
		None	None	18.5	30	18	95	22.3	30	22	99	20.2	30	20	97	24	30	24	101	101										
		17.0	20.4	28.0	30	26	95	32.8	35	30	99	30.1	35	28	97	34.9	35	32	101	101										
		34.0	40.9	53.6	60	49	95	58.4	60	50	99	55.8	60	51	97	60.5	70	56	101	101										
		51.0	61.3	63.8	70	73	95	68.6	80	77	99	65.9	70	75	97	70.7	80	79	101	101										
575-3-60	MED	None	None	19.3	30	19	106	23.1	30	23	110	21	30	21	108	24.8	30	25	112	112										
		17.0	20.4	29.0	30	27	106	33.8	35	31	110	31.1	35	29	108	35.9	40	33	112	112										
		34.0	40.9	54.6	60	50	106	59.4	60	55	110	56.8	60	52	108	61.5	70	57	112	112										
		51.0	61.3	64.8	70	74	106	69.6	80	78	110	66.9	70	76	108	71.7	80	80	112	112										
		None	None	22.1	30	22	120	25.9	30	26	124	23.8	30	24	122	27.6	35	28	126	126										
		17.0	20.4	32.5	35	30	120	37.3	40	34	124	34.6	35	32	122	39.4	40	36	126	126										
		34.0	40.9	58.1	60	53	120	62.9	70	58	124	60.3	70	55	122	65.0	80	60	126	126										
		51.0	61.3	68.3	80	77	120	73.1	80	81	124	70.4	80	79	122	75.2	80	83	126	126										

* Nominal values, listed as 208/240V, 460V or 600V as appropriate.

ELECTRICAL INFORMATION (UNITS PRODUCED PRIOR TO JULY 30, 2012) cont.

Table 27 – 50TC*D12 UNIT WIRE/FUSE OR HACR BREAKER SIZING DATA 2-STAGE COOLING WITH SINGLE SPEED INDOOR FAN MOTOR

NOM. V- Φ -Hz.	IFM TYPE	ELECTRIC HEATER										W/PWRD C.O.									
		NO C.O. or UNPWR C.O.					w/ PE. (pwrd fr/unit)					NO PE.					w/ PE. (pwrd fr/unit)				
		Nom* (kW)	FLA	MCA	MAX FUSE or HACR BRKR	DISC. SIZE FLA LRA	MCA	MAX FUSE or HACR BRKR	DISC. SIZE FLA LRA	MCA	MAX FUSE or HACR BRKR	DISC. SIZE FLA LRA	MCA	MAX FUSE or HACR BRKR	DISC. SIZE FLA LRA	MCA	MAX FUSE or HACR BRKR	DISC. SIZE FLA LRA			
208/ 230-3-60	STD	7.8/10.4	-	43.7	50	46/46	258	47.5	60	50	262	48.5	60	51	263	52.3	60	56	267		
		12.0/16.0	21.7/25.0	43.7/43.7	50/50	46/46	258/258	47.5/47.5	60/60	50/50	262/262	48.5/48.5	60/60	51/51	263/263	52.3/52.3	60/60	56/56	267/267		
		24.0/32.0	33.4/38.5	48.3/54.6	50/60	46/50	258/258	53.0/59.4	60/60	50/55	262/262	54.3/60.6	60/70	51/56	263/263	59.0/65.4	60/70	56/60	267/267		
		31.8/42.4	66.7/77.0	89.9/102.8	90/110	83/95	258/258	94.6/107.5	100/110	87/99	262/262	95.9/108.8	100/110	88/100	263/263	100.6/113.5	110/125	93/104	267/267		
		37.6/50.0	88.4/102.0	117.0/134.0	125/150	108/123	258/258	121.8/138.8	125/150	112/128	262/262	123.0/140.0	125/150	113/129	263/263	127.8/144.8	150/150	118/133	267/267		
		-	104.2/120.3	136.8/126.8	150/150	126/144	258/258	141.5/131.6	150/150	130/149	262/262	142.8/132.8	150/150	131/150	263/263	147.5/137.6	150/150	136/154	267/267		
		7.8/10.4	-	48.5	60	51	301	52.3	60	56	305	53.3	60	57	306	57.1	70	61	310		
		12.0/16.0	21.7/25.0	48.5/48.5	60/60	51/51	301/301	52.3/52.3	60/60	56/56	305/305	53.3/53.3	60/60	57/57	306/306	57.1/57.1	70/70	61/61	310/310		
		24.0/32.0	33.4/38.5	54.3/60.6	60/70	51/56	301/301	59.0/65.4	60/70	56/60	305/305	60.3/66.6	70/70	57/61	306/306	65.0/71.4	70/80	61/66	310/310		
		31.8/42.4	66.7/77.0	95.9/108.8	100/110	88/100	301/301	100.6/113.5	110/125	93/104	305/305	101.9/114.8	110/125	94/106	306/306	106.6/119.5	110/125	98/110	310/310		
460-3-60	STD	7.8/10.4	-	53.5	60	57	310	57.3	70	61	314	58.3	70	62	315	62.1	70	67	319		
		12.0/16.0	21.7/25.0	53.5/53.5	60/60	57/57	310/310	57.3/57.3	70/70	61/61	314/314	58.3/58.3	70/70	62/62	315/315	62.1/62.1	70/70	67/67	319/319		
		24.0/32.0	33.4/38.5	60.5/66.9	70/70	57/62	310/310	65.3/71.6	70/80	61/66	314/314	66.5/72.9	70/80	62/67	315/315	71.3/77.6	80/80	67/71	319/319		
		31.8/42.4	66.7/77.0	102.1/115.0	110/125	94/106	310/310	106.9/119.8	110/125	98/110	314/314	108.1/121.0	110/125	99/111	315/315	112.9/125.8	125/150	104/116	319/319		
		37.6/50.0	88.4/102.0	129.3/146.3	150/150	119/135	310/310	134.0/151.0	150/175	123/139	314/314	135.3/152.3	150/175	124/140	315/315	140.0/157.0	150/175	129/144	319/319		
		-	104.2/120.3	148.0/139.1	150/175	137/156	310/310	153.8/143.8	175/175	141/160	314/314	155.0/145.1	175/175	143/161	315/315	159.8/149.8	175/175	147/165	319/319		
		13.9	16.7	24.1	25	23	123	23.3	30	25	125	23.7	30	25	125	25.5	30	27	127		
		16.5	19.8	28.0	30	26	123	30.3	35	28	125	30.8	35	28	125	33.0	35	30	127		
		33.0	39.7	52.9	60	49	123	55.1	60	51	125	55.6	60	51	125	57.9	60	53	127		
		41.7	50.2	66.0	70	61	123	66.3	70	63	125	68.8	70	63	125	71.0	80	65	127		
575-3-60	STD	7.8/10.4	-	63.4	70	72	123	65.6	70	74	125	66.1	70	75	125	68.4	70	77	127		
		12.0/16.0	16.7	24.1	25	23	123	23.3	30	25	125	23.7	30	25	125	25.5	30	27	127		
		24.0/32.0	19.8	28.0	30	26	123	30.3	35	28	125	30.8	35	28	125	33.0	35	30	127		
		31.8/42.4	39.7	52.9	60	49	123	55.1	60	51	125	55.6	60	51	125	57.9	60	53	127		
		37.6/50.0	50.2	66.0	70	61	123	66.3	70	63	125	68.8	70	63	125	71.0	80	65	127		
		-	104.2/120.3	148.0/139.1	150/175	137/156	310/310	153.8/143.8	175/175	141/160	314/314	155.0/145.1	175/175	143/161	315/315	159.8/149.8	175/175	147/165	319/319		
		13.9	16.7	24.1	25	23	123	23.3	30	25	125	23.7	30	25	125	25.5	30	27	127		
		16.5	19.8	28.0	30	26	123	30.3	35	28	125	30.8	35	28	125	33.0	35	30	127		
		33.0	39.7	52.9	60	49	123	55.1	60	51	125	55.6	60	51	125	57.9	60	53	127		
		41.7	50.2	66.0	70	61	123	66.3	70	63	125	68.8	70	63	125	71.0	80	65	127		
575-3-60	MED	7.8/10.4	-	65.6	80	74	145	67.9	80	76	147	68.4	80	77	147	70.6	80	79	149		
		12.0/16.0	16.7	24.1	25	23	123	23.3	30	25	125	23.7	30	25	125	25.5	30	27	127		
		24.0/32.0	19.8	28.0	30	26	123	30.3	35	28	125	30.8	35	28	125	33.0	35	30	127		
		31.8/42.4	39.7	52.9	60	49	123	55.1	60	51	125	55.6	60	51	125	57.9	60	53	127		
		37.6/50.0	50.2	66.0	70	61	123	66.3	70	63	125	68.8	70	63	125	71.0	80	65	127		
		-	104.2/120.3	148.0/139.1	150/175	137/156	310/310	153.8/143.8	175/175	141/160	314/314	155.0/145.1	175/175	143/161	315/315	159.8/149.8	175/175	147/165	319/319		
		13.9	16.7	24.1	25	23	123	23.3	30	25	125	23.7	30	25	125	25.5	30	27	127		
		16.5	19.8	28.0	30	26	123	30.3	35	28	125	30.8	35	28	125	33.0	35	30	127		
		33.0	39.7	52.9	60	49	123	55.1	60	51	125	55.6	60	51	125	57.9	60	53	127		
		41.7	50.2	66.0	70	61	123	66.3	70	63	125	68.8	70	63	125	71.0	80	65	127		
575-3-60	HIGH	7.8/10.4	-	68.4	80	74	145	67.9	80	76	147	68.4	80	77	147	70.6	80	79	149		
		12.0/16.0	16.7	24.1	25	23	123	23.3	30	25	125	23.7	30	25	125	25.5	30	27	127		
		24.0/32.0	19.8	28.0	30	26	123	30.3	35	28	125	30.8	35	28	125	33.0	35	30	127		
		31.8/42.4	39.7	52.9	60	49	123	55.1	60	51	125	55.6	60	51	125	57.9	60	53	127		
		37.6/50.0	50.2	66.0	70	61	123	66.3	70	63	125	68.8	70	63	125	71.0	80	65	127		
		-	104.2/120.3	148.0/139.1	150/175	137/156	310/310	153.8/143.8	175/175	141/160	314/314	155.0/145.1	175/175	143/161	315/315	159.8/149.8	175/175	147/165	319/319		
		13.9	16.7	24.1	25	23	123	23.3	30	25	125	23.7	30	25	125	25.5	30	27	127		
		16.5	19.8	28.0	30	26	123	30.3	35	28	125	30.8	35	28	125	33.0	35	30	127		
		33.0	39.7	52.9	60	49	123	55.1	60	51	125	55.6	60	51	125	57.9	60	53	127		
		41.7	50.2	66.0	70	61	123	66.3	70	63	125	68.8	70	63	125	71.0	80	65	127		
575-3-60	HIGH	7.8/10.4	-	68.4	80	74	145	67.9	80	76	147	68.4	80	77	147	70.6	80	79	149		
		12.0/16.0	16.7	24.1	25	23	123	23.3	30	25	125	23.7	30	25	125	25.5	30	27	127		
		24.0/32.0	19.8	28.0	30	26	123	30.3	35	28	125	30.8	35	28	125	33.0	35	30	127		
		31.8/42.4	39.7	52.9	60	49	123	55.1	60	51	125	55.6	60	51	125	57.9	60	53	127		
		37.6/50.0	50.2	66.0	70	61	123	66.3	70	63	125	68.8	70	63	125	71.0	80	65	127		
		-	104.2/120.3	148.0/139.1	150/175	137/156	310/310	153.8/143.8	175/175	141/160	314/314	155.0/145.1	175/175	143/161	315/315	159.8/149.8	175/175	147/165	319/319		
		13.9	16.7	24.1	25	23	123	23.3	30	25	125	23.7	30	25	125	25.5	30	27	127		
		16.5	19.8	28.0	30	26	123	30.3	35	28	125	30.8	35	28	125	33.0	35	30	127		
		33.0	39.7	52.9	60	49	123	55.1	60	51	125	55.6	60	51	125	57.9	60	53	127		
		41.7	50.2	66.0	70	61	123	66.3	70	63	125	68.8	70	63	125	71.0	80	65	127		

* Nominal values, listed as 208/240V, 460V or 600V as appropriate.

ELECTRICAL INFORMATION (UNITS PRODUCED PRIOR TO JULY 30, 2012) cont.

Table 29 – 50TC*D14 UNIT WIRE/FUSE OR HACR BREAKER SIZING DATA 2-STAGE COOLING WITH SINGLE SPEED INDOOR FAN MOTOR

NOM. V-PH-Hz.	ELECTRIC HEATER										NO C.O. or UNPWR C.O.										W/PWR C.O.									
	IFM TYPE	Nom* (kW)	FLA	NO PE.		NO PE.		NO PE.		w/ P.E. (pwrd fr/unit)		NO PE.		NO PE.		w/ P.E. (pwrd fr/unit)		NO PE.		NO PE.		w/ P.E. (pwrd fr/unit)								
				MCA	MAX FUSE or HACR BRKR	DISC. SIZE FLA LRA	MCA	MAX FUSE or HACR BRKR	DISC. SIZE FLA LRA	MCA	MAX FUSE or HACR BRKR	DISC. SIZE FLA LRA	MCA	MAX FUSE or HACR BRKR	DISC. SIZE FLA LRA	MCA	MAX FUSE or HACR BRKR	DISC. SIZE FLA LRA	MCA	MAX FUSE or HACR BRKR	DISC. SIZE FLA LRA	MCA	MAX FUSE or HACR BRKR	DISC. SIZE FLA LRA						
208/ 230-3-60	STD	7.8/10.4	21.7/25.0	60.7	80	63	360	64.5	80/80	68	364	65.5	80	69	365	69.3	80/80	69	365	69.3	80/80	73	369							
		12.0/16.0	33.4/38.5	60.7/60.7	80/80	63/63	360/360	64.5/64.5	80/80	68/68	364/364	65.5/65.5	80/80	69/69	365/365	69.3/69.3	80/80	73/73	369/369											
		24.0/32.0	66.7/77.0	92.8/105.6	100/110	85/97	360/360	97.5/110.4	100/125	90/102	364/364	98.9/111.6	100/125	91/103	365/365	103.5/116.4	110/125	95/107	369/369											
		31.8/42.4	88.4/102.0	119.9/136.9	125/150	110/126	360/360	124.6/141.6	125/150	115/130	364/364	125.9/142.9	150/150	116/131	365/365	130.6/147.6	150/150	120/136	369/369											
		37.6/50.0	104.2/120.3	139.6/129.7	150/150	128/147	360/360	144.4/134.4	150/150	133/151	364/364	145.6/135.7	150/150	134/152	365/365	150.4/140.4	175/150	138/157	369/369											
		7.8/10.4	21.7/25.0	63.2/63.2	80/80	66	377	67.0	80	71	381	68.0	80	72	382	71.8	80/80	76	386											
		12.0/16.0	33.4/38.5	63.2/63.2	80/80	66/66	377/377	67.0/67.0	80/80	71/71	381/381	68.0/68.0	80/80	72/72	382/382	71.8/71.8	80/80	76/76	386/386											
		24.0/32.0	66.7/77.0	95.9/108.8	100/110	88/100	377/377	100.6/113.5	110/125	93/104	381/381	101.9/114.8	110/125	94/106	382/382	106.6/119.5	110/125	98/110	386/386											
		31.8/42.4	88.4/102.0	123.0/140.0	125/150	113/129	377/377	127.8/144.8	150/150	118/133	381/381	129.0/146.0	150/150	119/134	382/382	133.8/150.8	150/175	123/139	386/386											
		37.6/50.0	104.2/120.3	142.8/132.8	150/150	131/150	377/377	147.5/137.6	150/150	136/154	381/381	148.8/138.8	150/150	137/155	382/382	153.5/143.6	175/175	141/160	386/386											
460-3-60	HIGH	7.8/10.4	21.7/25.0	68.2	80	72	386	72.0	80/80	76	390	73.0	80	78	391	76.8	90/90	82	395											
		12.0/16.0	33.4/38.5	68.2/68.2	80/80	72/72	386/386	72.0/72.0	80/80	76/76	390/390	73.0/73.0	80/80	78/78	391/391	76.8/76.8	90/90	82/82												
		24.0/32.0	66.7/77.0	102.1/115.0	110/125	94/106	386/386	106.9/119.8	110/125	98/110	390/390	108.1/121.0	110/125	99/111	391/391	112.9/125.8	125/150	104/116	395/395											
		31.8/42.4	88.4/102.0	129.3/146.3	150/150	119/135	386/386	134.0/151.0	150/175	123/139	390/390	135.3/152.3	150/175	124/140	391/391	140.0/157.0	150/175	129/144	395/395											
		37.6/50.0	104.2/120.3	149.0/139.1	150/175	137/156	386/386	153.8/143.8	175/175	141/160	390/390	155.0/145.1	175/175	143/161	391/391	159.8/149.8	175/175	147/165	395/395											
		13.9	16.7	29.5	40	31	181	31.3	40	33	183	31.7	40	33	183	33.5	40	35	185											
		16.5	19.8	29.5	40	31	181	31.3	40	33	183	31.7	40	33	183	33.5	40	35	185											
		33.0	39.7	53.9	60	50	181	56.1	60	52	183	56.6	60	52	183	58.9	60	54	185											
		41.7	50.2	67.0	70	62	181	69.3	70	64	183	69.8	70	64	183	72.0	80	66	185											
		50.0	60.1	64.4	70	73	181	66.6	70	75	183	67.1	70	76	183	69.4	80	78	185											
575-3-60	STD	13.9	16.7	30.5	40	32	190	32.3	40	34	192	32.7	40	35	192	34.5	45	37												
		16.5	19.8	30.5	40	32	190	32.3	40	34	192	32.7	40	35	192	34.5	45	37												
		33.0	39.7	55.1	60	51	190	57.4	60	53	192	57.9	60	53	192	63.9	70	59												
		41.7	50.2	68.3	70	63	190	70.5	80	65	192	71.0	80	65	192	73.3	80	67												
		50.0	60.1	65.6	80	74	190	67.9	80	76	192	68.4	80	77	192	70.6	80	79												
		13.9	16.7	33.5	40	35	194	35.3	45	37	196	35.7	45	38	196	37.5	45	40												
		16.5	19.8	34.0	40	35	194	36.3	45	37	196	36.8	45	38	196	39.0	45	40												
		33.0	39.7	56.9	60	54	194	61.1	70	56	196	61.6	70	57	196	63.9	70	59												
		41.7	50.2	72.0	80	66	194	74.3	80	68	196	74.8	80	69	196	77.0	80	71												
		50.0	60.1	69.4	80	78	194	71.6	80	80	196	72.1	80	80	196	74.4	80	82												
575-3-60	MED	17.0	20.4	22.3	30	23	142	26.1	30	28	146	24.0	30	25	144	27.8	30	30												
		34.0	40.9	54.6	60	50	142	59.4	60	55	146	56.8	60	52	144	61.5	70	57												
		51.0	61.3	64.8	70	74	142	69.6	80	78	146	66.9	70	76	144	71.7	80	80												
		17.0	20.4	22.3	30	23	142	26.1	30	28	146	24.0	30	25	144	27.8	30	30												
		34.0	40.9	54.6	60	50	142	59.4	60	55	146	56.8	60	52	144	61.5	70	57												
		51.0	61.3	64.8	70	74	142	69.6	80	78	146	66.9	70	76	144	71.7	80	80												
		17.0	20.4	25.1	30	27	156	28.9	35	31	160	26.8	30	29	158	30.6	35	33												
		34.0	40.9	58.1	60	53	156	62.9	70	58	160	60.3	70	55	158	65.0	70	60												
		51.0	61.3	68.3	80	77	156	73.1	80	81	160	70.4	80	79	158	75.2	80	83												

* Nominal values, listed as 208/240V, 480V or 600V as appropriate.

ELECTRICAL INFORMATION (UNITS PRODUCED PRIOR TO JULY 30, 2012) cont.

Table 31 – 50TC*DI6 UNIT WIRE/FUSE OR HACR BREAKER SIZING DATA 2-STAGE COOLING WITH SINGLE SPEED INDOOR FAN MOTOR

NOM. V-PH-Hz.	ELECTRIC HEATER										NO P.E.										W/ P.E. (pwrd fr/unit)													
	IFM TYPE	Nom* (kW)	FLA	NO P.E.			W/ P.E. (pwrd fr/unit)			NO P.E.			W/ P.E. (pwrd fr/unit)			NO P.E.			W/ P.E. (pwrd fr/unit)			NO P.E.			W/ P.E. (pwrd fr/unit)									
				MAX FUSE or HACR BRKR	MCA	DISC. SIZE	FLA	LRA	DISC. SIZE	MCA	MAX FUSE or HACR BRKR	FLA	LRA	DISC. SIZE	FLA	LRA	DISC. SIZE	MCA	MAX FUSE or HACR BRKR	FLA	LRA	DISC. SIZE	FLA	LRA	DISC. SIZE	FLA	LRA	DISC. SIZE	FLA	LRA	DISC. SIZE			
208/ 230-3-60	STD	12.4/16.5	34.4/39.7	-	71	396	72.1	80	80	76	400	77	401	76.9	100	81	405	80/80	77/77	401/401	76.9/76.9	100/100	81/81	405/405	80/80	77/77	401/401	76.9/76.9	100/100	81/81	405/405			
		25.2/33.5	69.9/80.6	68.3/68.3	80/80	71/71	396/396	72.1/72.1	80/80	80/80	76/76	400/400	95/106	400/400	107.5/120.9	110/125	99/111	405/405	100/125	118/135	401/401	133.5/151.0	150/175	123/139	150/175	138/157	405/405	150/175	138/157	405/405				
		37.6/50.0	104.3/120.3	122.8/140.3	100/125	113/129	396/396	127.5/145.0	150/150	150/150	117/133	400/400	133/151	400/400	153.6/181.3	150/150	138/157	405/405	150/150	148.9/138.8	417/417	153.6/143.6	175/175	141/160	422/422	150/150	134/152	401/401	150.5/140.4	175/175	141/160	422/422		
		50.3/67.0	139.7/161.2	149.1/170.6	175/200	169/194	396/396	153.9/175.3	175/200	175/200	174/198	400/400	175/200	400/400	178.2/197.7	175/200	175/200	405/405	175/200	158.2/179.7	417/417	163.0/184.5	175/200	182/207	422/422	175/200	175/200	401/401	159.8/181.3	175/200	179/204	405/405		
		12.4/16.5	34.4/39.7	70.8	80	413	74.6	90	90	79	417	417	80	418	79.4	100	84	422	80/80	79/79	417/417	79.4/79.4	100/100	84/84	422/422	80/80	79/79	417/417	79.4/79.4	100/100	84/84	422/422		
		25.2/33.5	69.9/80.6	99.9/113.3	100/125	92/104	413/413	104.6/118.0	110/125	110/125	96/109	417/417	108/121	436/436	118.9/132.3	125/150	109/122	437/437	114/126	125/150	133.5/151.0	418/418	110.6/124.0	125/125	102/114	422/422	110/125	95/107	401/401	107.5/120.9	110/125	99/111	405/405	
		32.7/43.5	90.7/104.7	125.9/143.4	150/150	116/132	413/413	130.6/148.1	150/150	150/150	120/136	417/417	132/148	436/436	144.9/162.4	150/175	133/149	437/437	149.6/167.1	150/175	148.9/138.8	418/418	136.6/154.1	150/175	126/142	422/422	118/135	401/401	133.5/151.0	150/175	123/139	150/175	138/157	405/405
		37.6/50.0	104.3/120.3	142.9/132.8	150/150	131/150	413/413	147.6/137.6	150/150	150/150	136/154	417/417	148/166	436/436	161.9/151.8	175/175	149/167	437/437	166.6/156.6	175/175	153.6/143.6	418/418	153.6/143.6	175/175	141/160	422/422	137/155	418/418	153.6/143.6	175/175	141/160	422/422		
		50.3/67.0	139.7/161.2	152.2/173.7	175/200	172/197	413/413	157.0/178.5	175/200	175/200	177/201	417/417	188/213	436/436	171.2/192.7	200/225	190/214	437/437	176.0/197.5	200/225	158.2/179.7	418/418	163.0/184.5	175/200	182/207	422/422	178/202	418/418	163.0/184.5	175/200	182/207	422/422		
		12.4/16.5	34.4/39.7	81.2/81.2	100/100	86/86	432/432	85.0/85.0	100/100	100/100	91/91	436/436	86.0/86.0	100/100	436/436	86.0/86.0	92/92	437/437	89.8/89.8	100/100	89.8/89.8	437/437	89.8/89.8	100/100	96/96	441/441	100/100	92/92	437/437	89.8/89.8	100/100	96/96	441/441	
25.2/33.5	69.9/80.6	112.9/126.3	125/150	104/116	432/432	117.6/131.0	125/150	125/150	108/121	436/436	118.9/132.3	150/175	132/148	144.9/162.4	133/149	437/437	149.6/167.1	150/175	133.5/151.0	437/437	123.6/137.0	125/150	114/126	441/441	150/175	133/149	437/437	149.6/167.1	150/175	138/157	441/441			
32.7/43.5	90.7/104.7	138.9/156.4	150/175	128/144	432/432	143.6/161.1	150/175	150/175	120/136	417/417	148/166	436/436	161.9/151.8	175/175	149/167	437/437	166.6/156.6	175/175	148.9/138.8	437/437	166.6/156.6	175/175	153/172	441/441	175/175	149/167	437/437	166.6/156.6	175/175	153/172	441/441			
37.6/50.0	104.3/120.3	155.9/145.8	175/175	143/162	432/432	160.6/150.6	175/175	175/175	148/166	436/436	161.9/151.8	175/175	148/166	160.6/150.6	148/166	436/436	166.6/156.6	175/175	153.6/143.6	437/437	166.6/156.6	175/175	153/172	441/441	175/175	149/167	437/437	166.6/156.6	175/175	153/172	441/441			
50.3/67.0	139.7/161.2	165.2/186.7	175/225	184/209	432/432	170.0/191.5	175/225	175/225	188/213	436/436	171.2/192.7	200/225	188/213	170.0/191.5	190/214	437/437	176.0/197.5	200/225	158.2/179.7	437/437	176.0/197.5	200/225	194/219	441/441	200/225	190/214	437/437	176.0/197.5	200/225	194/219	441/441			
16.5	19.9	34.0	45	35	234	35.8	45	45	37	236	36.2	45	45	38	236	36.2	45	45	38	236	36.2	45	45	38	236	36.2	45	45	38	236	36.2	45	45	
33.5	40.3	54.6	60	50	234	56.9	60	60	52	236	57.4	60	60	53	236	57.4	60	60	52	236	57.4	60	60	53	236	57.4	60	60	52	236	57.4	60	60	
43.5	52.3	69.6	70	64	234	71.9	70	70	66	236	72.6	70	70	67	236	72.6	70	70	66	236	72.6	70	70	67	236	72.6	70	70	66	236	72.6	70	70	
50.0	60.2	84.5	70	73	234	86.7	70	70	75	236	87.2	70	70	76	236	87.2	70	70	75	236	87.2	70	70	76	236	87.2	70	70	75	236	87.2	70	70	
67.0	80.6	84.9	90	97	234	87.1	100	100	99	236	87.6	100	100	100	236	87.6	100	100	99	236	87.6	100	100	101	236	87.6	100	100	99	236	87.6	100	100	
16.5	19.9	35.0	45	37	243	36.8	45	45	39	245	37.2	45	45	39	245	37.2	45	45	39	245	37.2	45	45	39	245	37.2	45	45	39	245	37.2	45	45	
33.5	40.3	55.9	60	51	243	58.1	60	60	53	243	58.6	60	60	54	243	58.6	60	60	53	243	58.6	60	60	54	243	58.6	60	60	53	243	58.6	60	60	
43.5	52.3	70.9	80	65	243	73.1	80	80	67	243	73.6	80	80	68	243	73.6	80	80	67	243	73.6	80	80	68	243	73.6	80	80	67	243	73.6	80	80	
50.0	60.2	85.7	80	74	243	88.0	80	80	76	243	88.5	80	80	77	243	88.5	80	80	76	243	88.5	80	80	77	243	88.5	80	80	76	243	88.5	80	80	
67.0	80.6	86.1	100	98	243	88.4	100	100	100	243	88.4	100	100	100	243	88.4	100	100	100	243	88.4	100	100	102	247	88.4	100	100	99	247	88.4	100	100	
16.5	19.9	40.8	50	43	252	42.6	50	50	45	254	43.0	50	50	46	254	43.0	50	50	45	254	43.0	50	50	46	254	43.0	50	50	45	254	43.0	50	50	
33.5	40.3	63.1	70	58	252	65.4	70	70	56	254	65.9	70	70	57	254	65.9	70	70	56	254	65.9	70	70	57	254	65.9	70	70	56	254	65.9	70	70	
43.5	52.3	78.1	80	72	252	80.4	80	80	74	254	80.9	80	80	74	254	80.9	80	80	74	254	80.9	80	80	74	254	80.9	80	80	74	254	80.9	80	80	
50.0	60.2	93.0	80	81	252	95.2	80	80	83	254	95.7	80	80	83	254	95.7	80	80	83	254	95.7	80	80	83	254	95.7	80	80	83	254	95.7	80	80	
67.0	80.6	96.4	100	104	252	95.6	100	100	106	254	96.1	100	100	106	254	96.1	100	100	106	254	96.1	100	100	107	256	96.1	100	100	106	254	96.1	100	100	
16.5	19.9	26.5	30	28	184	30.3	30	30	32	188	28.2	35	35	30	186	28.2	35	35	30	186	28.2	35	35	30	186	28.2	35	35	30	186	28.2	35	35	
33.5	40.3	43.8	45	40	184	48.5	45	45	45	188	45.9	50	50	42	186	45.9	50	50	42	186	45.9	50	50	42	186	45.9	50	50	42	186	45.9	50	50	
43.5	52.3	55.8	60	51	184	60.5	60	60	56	188	57.9	60	60	53	186	57.9	60	60	53	186	57.9	60	60	53	186	57.9	60	60	53	186	57.9	60	60	
50.0	60.2	67.9	80	77	184	67.2	80	80	77	184																								

LEGEND:

- BRKR - Circuit breaker
- CO - Convenience outlet
- DISC - Disconnect
- FLA - Full load amps
- IFM - Indoor fan motor
- LRA - Locked rotor amps
- MCA - Minimum circuit amps
- MOCP - MAX FUSE or HACR Breaker
- PE - Power exhaust
- PWRD CO - Powered convenient outlet
- UNPWR CO - Unpowered convenient outlet



NOTES:

1. In compliance with NEC requirements for multimotor and combination load equipment (refer to NEC Articles 430 and 440), the overcurrent protective device for the unit shall be fuse or HACR breaker. Canadian units may be fuse or circuit breaker.
2. **Unbalanced 3-Phase Supply Voltage**
 Never operate a motor where a phase imbalance in supply voltage is greater than 2%.
 Use the following formula to determine the percentage of voltage imbalance.

$$\% \text{ Voltage Imbalance} = 100 \times \frac{\text{max voltage deviation from average voltage}}{\text{average voltage}}$$

Example: Supply voltage is 230-3-60



AB = 224 v
 BC = 231 v
 AC = 226 v

$$\text{Average Voltage} = \frac{(224 + 231 + 226)}{3} = \frac{681}{3} = 227$$

Determine maximum deviation from average voltage.

(AB) 227 - 224 = 3 v
 (BC) 231 - 227 = 4 v
 (AC) 227 - 226 = 1 v

Maximum deviation is 4 v.

Determine percent of voltage imbalance.

$$\% \text{ Voltage Imbalance} = 100 \times \frac{4}{227} = 1.76\%$$

This amount of phase imbalance is satisfactory as it is below the maximum allowable 2%.

IMPORTANT: If the supply voltage phase imbalance is more than 2%, contact your local electric utility company immediately.

SEQUENCE OF OPERATION

General

The sequence below describes the sequence of operation for an electromechanical unit with and without a factory installed EconoMi\$er™ IV and X (called “economizer” in this sequence). For information regarding a direct digital controller, see the start-up, operations, and troubleshooting manual for the applicable controller.

Electromechanical units with no economizer

Cooling (Single speed indoor fan motor) —

When the thermostat calls for cooling, terminals G and Y1 are energized. As a result, the indoor fan contactor (IFC) and the compressor contactor (C1) are energized, causing the indoor fan motor (IFM), compressor #1, and outdoor fan to start. If the unit has 2 stages of cooling, the thermostat will additionally energize Y2. The Y2 signal will energize compressor contactor #2 (C2), causing compressor #2 to start. Regardless of the number of stages, the outdoor fan motor runs continuously while unit is cooling.

Cooling (2-speed indoor fan motor) —

Per ASHRAE 90.1 2010 standard section 6.4.3.10.b, during the first stage of cooling operation the VFD will adjust the fan motor to provide 2/3rd of the total cfm established for the unit. When a call for the second stage of cooling is required, the VFD will allow the total cfm for the unit established (100%).

Heating

NOTE: The 50TC is sold as cooling only. If electric heaters are required, use only factory-approved electric heaters. They will operate as described below.

Units have either 1 or 2 stages of electric heat. When the thermostat calls for heating, power is applied to the W1 terminal at the unit. The unit control will energize the indoor fan contactor and the first stage of electric heat. On units with 2-stage heating, when additional heating is required, the second stage of electric heat (if equipped) will be energized when power is applied at the W2 terminal on the unit.

Electromechanical units with an economizer

Cooling —

When free cooling is not available, the compressors will be controlled by the zone thermostat. When free cooling is available, the outdoor air damper is modulated by the EconoMi\$er IV and X control to provide a 50°F (10°C) to 55°F (13°C) mixed air temperature into the zone. As the mixed air temperature fluctuates above 55°F (13°C) or below 50°F (10°C) dampers will be modulated (open or close) to bring the mixed air temperature back within control. If mechanical cooling is utilized with free cooling, the outdoor air damper will maintain its current position at the time the compressor is started. If the

increase in cooling capacity causes the mixed air temperature to drop below 45°F (9°C), then the outdoor air damper position will be decreased to the minimum position. If the mixed air temperature continues to fall, the outdoor air damper will close. Control returns to normal once the mixed air temperature rises above 48°F (9°C). The power exhaust fans will be energized and de-energized, if installed, as the outdoor air damper opens and closes.

If field-installed accessory CO₂ sensors are connected to the EconoMi\$er IV and X control, a demand controlled ventilation strategy will begin to operate. As the CO₂ level in the zone increases above the CO₂ setpoint, the minimum position of the damper will be increased proportionally. As the CO₂ level decreases because of the increase in fresh air, the outdoor air damper will be proportionally closed. For EconoMi\$er IV and X operation, there must be a thermostat call for the fan (G). If the unit is occupied and the fan is on, the damper will operate at minimum position. Otherwise, the damper will be closed.

When the EconoMi\$er IV and X control is in the occupied mode and a call for cooling exists (Y1 on the thermostat), the control will first check for indoor fan operation. If the fan is not on, then cooling will not be activated. If the fan is on, then the control will open the EconoMi\$er IV and X damper to the minimum position.

On the initial power to the EconoMi\$er IV and X control, it will take the damper up to 2 1/2 minutes before it begins to position itself. After the initial power-up, further changes in damper position can take up to 30 seconds to initiate. Damper movement from full closed to full open (or vice versa) will take between 1 1/2 and 2 1/2 minutes. If free cooling can be used as determined from the appropriate changeover command (switch, dry bulb, enthalpy curve, differential dry bulb, or differential enthalpy), then the control will modulate the dampers open to maintain the mixed air temperature setpoint at 50°F (10°C) to 55°F (13°C). If there is a further demand for cooling (cooling second stage - Y2 is energized), then the control will bring on compressor stage 1 to maintain the mixed air temperature setpoint. The EconoMi\$er IV and X damper will be open at maximum position. EconoMi\$er IV and X operation is limited to a single compressor.

2-Speed Note: When operating in ventilation mode only, the indoor fan motor will automatically adjust to 2/3rd of the total cfm established.

Heating

The sequence of operation for the heating is the same as an electromechanical unit with no economizer. The only difference is how the economizer acts. The economizer will stay at the Economizer Minimum Position while the evaporator fan is operating. The outdoor air damper is closed when the indoor fan is not operating.

SEQUENCE OF OPERATION (cont.)

Optional Humidi-MiZer Dehumidification System

Units with the factory equipped Humidi-MiZer option are capable of providing multiple modes of improved dehumidification as a variation of the normal cooling cycle. The Humidi-MiZer option includes additional valves in the liquid line and discharge line of each refrigerant circuit, a small reheat condenser coil downstream of the evaporator, and Motormaster variable-speed control of some or all outdoor fans. Operation of the revised refrigerant circuit for each mode is described below.

The Humidi-MiZer system provides three sub-modes of operation: Cool, Reheat1, and Reheat2.

Cool mode - provides a normal ratio of Sensible and Latent Cooling effect from the evaporator coil.

Reheat1 - provides increased Latent Cooling while slightly reducing the Sensible Cooling effect.

Reheat2 - provides normal Latent Cooling but with null or minimum Sensible Cooling effect delivered to the space.

The Reheat1 and Reheat2 modes are available when the unit is not in a Heating mode and when the Low Ambient Lockout switch is closed.

The following diagrams depict piping for Single Stage cooling units.

SEQUENCE OF OPERATION (cont.)

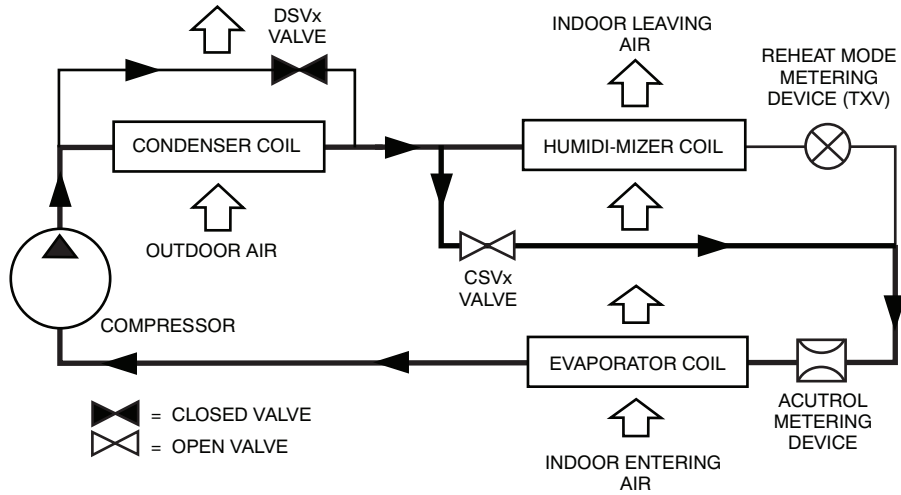

C12647

Normal Cooling Mode - Humidi-MiZer System with Single Stage Cooling

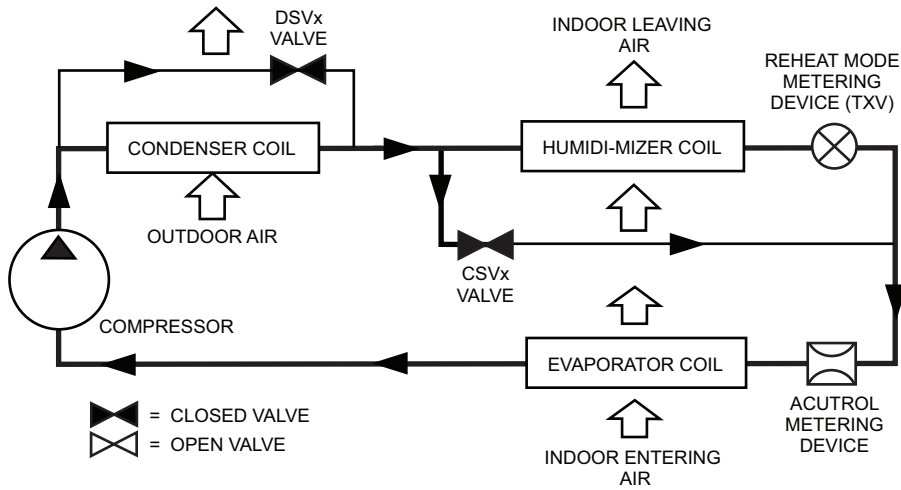

C12648

Subcooling Mode (Reheat 1) - Humidi-MiZer System with Single Stage Cooling

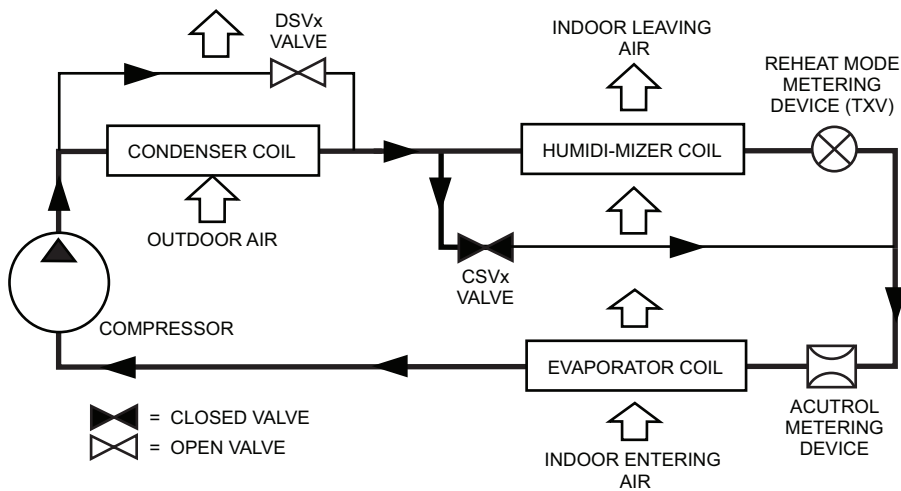

C12649

Hot Gas Reheat Mode (Reheat 2) - Humidi-MiZer System with Single Stage Cooling

Cooling Only/Electric Heat Packaged Rooftop

HVAC Guide Specifications

Size Range: 3 to 15 Nominal Tons



<u>Section</u>	<u>Description</u>
----------------	--------------------

23 06 80	Schedules for Decentralized HVAC Equipment
-----------------	---

- | | |
|----------------|---|
| 23 06 80.13 | Decentralized Unitary HVAC Equipment Schedule |
| 23 06 80.13.A. | Rooftop unit schedule |
| 1. | Schedule is per the project specification requirements. |

23 07 16	HVAC Equipment Insulation
-----------------	----------------------------------

- | | |
|----------------|---|
| 23 07 16.13 | Decentralized, Rooftop Units: |
| 23 07 16.13.A. | Evaporator fan compartment: |
| 1. | Interior cabinet surfaces shall be insulated with a minimum 1/2-in. thick, minimum 1 1/2 lb density, flexible fiberglass insulation bonded with a phenolic binder, neoprene coated on the air side. |
| 2. | Insulation and adhesive shall meet NFPA 90A requirements for flame spread and smoke generation. |
| 23 07 16.13.B. | Electric heat compartment: |
| 1. | Aluminum foil-faced fiberglass insulation shall be used. |
| 2. | Insulation and adhesive shall meet NFPA 90A requirements for flame spread and smoke generation. |

23 09 13	Instrumentation and Control Devices for HVAC
-----------------	---

- | | |
|----------------|---|
| 23 09 13.23 | Sensors and Transmitters |
| 23 09 13.23.A. | Thermostats |
| 1. | Thermostat must |
| a. | energize both "W" and "G" when calling for heat. |
| b. | have capability to energize 2 different stages of cooling, and 2 different stages of heating. |
| c. | include capability for occupancy scheduling. |

23 09 23	Direct-digital Control system for HVAC
-----------------	---

- | | |
|----------------|---|
| 23 09 23.13 | Decentralized, Rooftop Units: |
| 23 09 23.13.A. | PremierLink controller |
| 1. | Shall be ASHRAE 62-2001 compliant. |
| 2. | Shall accept 18-32VAC input power. |
| 3. | Shall have an operating temperature range from -40°F (-40°C) to 158°F (70°C), 10% - 95% RH (non-condensing). |
| 4. | Shall include an integrated economizer controller to support an economizer with 4 to 20 mA actuator input and no microprocessor controller. |
| 5. | Controller shall accept the following inputs: space temperature, setpoint adjustment, outdoor air temperature, indoor air quality, outdoor air quality, indoor relative humidity, compressor lock-out, fire shutdown, enthalpy, fan status, remote time clock/door switch. |
| 6. | Shall accept a CO ₂ sensor in the conditioned space, and be Demand Control Ventilation (DCV) ready. |
| 7. | Shall provide the following outputs: Economizer, fan, cooling stage 1, cooling stage 2, heat stage 1, heat stage 2, heat stage 3/ exhaust/ reversing valve/ dehumidify/ occupied. |
| 8. | Unit shall provide surge protection for the controller through a circuit breaker. |
| 9. | Shall be Internet capable, and communicate at a Baud rate of 38.4K or faster |
| 10. | Shall have an LED display independently showing the status of activity on the communication bus, and processor operation. |
| 11. | Shall include an EIA-485 protocol communication port, an access port for connection of either a computer or a Carrier technician tool, an EIA-485 port for network communication to intelligent space sensors and displays, and a port to connect an optional LonWorks plug-in communications card. |
| 12. | Shall have built-in Carrier Comfort Network (CCN) protocol, and be compatible with other CCN devices, including ComfortLink and ComfortVIEW controllers. |
| 13. | Shall have built-in support for Carrier technician tool. |

14. Software upgrades will be accomplished by local download. Software upgrades through chip replacements are not allowed.
15. Shall be shock resistant in all planes to 5G peak, 11ms during operation, and 100G peak, 11ms during storage.
16. Shall be vibration resistant in all planes to 1.5G @ 20-300 Hz.
17. Shall support a bus length of 4000 ft max, 60 devices per 1000 ft section, and 1 RS-485 repeater per 1000 ft sections.

23 09 23.13.B. Open protocol, direct digital controller:

1. Shall be ASHRAE 62-2001 compliant.
2. Shall accept 18-30VAC, 50-60Hz, and consumer 15VA or less power.
3. Shall have an operating temperature range from -40°F (-40°C) to 130°F (54°C), 10% - 90% RH (non-condensing).
4. Shall include built-in protocol for BACNET (MS/TP and PTP modes), Modbus (RTU and ASCII), Johnson N2 and LonWorks. LonWorks Echelon processor required for all Lon applications shall be contained in separate communication board.
5. Shall allow access of up to 62 network variables (SNVT). Shall be compatible with all open controllers
6. Baud rate Controller shall be selectable using a dipswitch.
7. Shall have an LED display independently showing the status of serial communication, running, errors, power, all digital outputs, and all analog inputs.
8. Shall accept the following inputs: space temperature, setpoint adjustment, outdoor air temperature, indoor air quality, outdoor air quality, compressor lock-out, fire shutdown, enthalpy switch, and fan status/filter status/humidity/ remote occupancy.
9. Shall provide the following outputs: economizer, fan, cooling stage 1, cooling stage 2, heat stage 1, heat stage 2, heat stage 3/ exhaust/ reversing valve.
10. Shall have built-in surge protection circuitry through solid state polyswitches. Polyswitches shall be used on incoming power and network connections. Polyswitches will return to normal when the "trip" condition clears.
11. Shall have a battery backup capable of a minimum of 10,000 hours of data and time clock retention during power outages.
12. Shall have built-in support for Carrier technician tool.
13. Shall include an EIA-485 protocol communication port, an access port for connection of either a computer or a Carrier technician tool, an EIA-485 port for network communication to intelligent space sensors and displays, and a port to connect an optional LonWorks communications card.
14. Software upgrades will be accomplished by either local or remote download. No software upgrades through chip replacements are allowed.

23 09 33 Electric and Electronic Control System for HVAC

23 09 33.13 Decentralized, Rooftop Units:

23 09 33.13.A. General:

1. Shall be complete with self-contained low-voltage control circuit protected by a resettable circuit breaker on the 24-v transformer side. Transformer shall have 75VA capability.
2. Shall utilize color-coded wiring.
3. Shall include a central control terminal board to conveniently and safely provide connection points for vital control functions such as: smoke detectors, phase monitor, economizer, thermostat, DDC control options, and low and high pressure switches.
4. Unit shall include a minimum of one 8-pin screw terminal connection board for connection of control wiring.

23 09 33.23.B. Safeties:

1. Compressor over-temperature, over current.
2. Low pressure switch.
 - a. Units with 2 compressors shall have different sized connectors for the circuit 1 and circuit 2 low and high pressure switches. They shall physically prevent the cross-wiring of the safety switches between circuits 1 and 2.
 - b. Low pressure switch shall use different color wire than the high pressure switch. The purpose is to assist the installer and service technician to correctly wire and or troubleshoot the rooftop unit.
3. High pressure switch.
 - a. Units with 2 compressors shall have different sized connectors for the circuit 1 and circuit 2 low and high pressure switches. They shall physically prevent the cross-wiring of the safety switches between circuits 1 and 2.

- b. High pressure switch shall use different color wire than the low pressure switch. The purpose is to assist the installer and service technician to correctly wire and or troubleshoot the rooftop unit.
4. Automatic reset, motor thermal overload protector.

23 09 93 Sequence of Operations for HVAC Controls

- 23 09 93.13 Decentralized, Rooftop Units:
- 23 09 93.13 INSERT SEQUENCE OF OPERATION

23 40 13 Panel Air Filters

- 23 40 13.13 Decentralized, Rooftop Units:
- 23 40 13.13.A. Standard filter section
 1. Shall consist of factory-installed, low velocity, throwaway 2-in. thick fiberglass filters of commercially available sizes.
 2. Unit shall use only one filter size. Multiple sizes are not acceptable.
 3. Filters shall be accessible through an access panel with “no-tool” removal as described in the unit cabinet section of this specification (23 81 19.13.H).

23 81 19 Self-Contained Air Conditioners

- 23 81 19.13 Small-Capacity Self-Contained Air Conditioners (50TC**04-16)
- 23 81 19.13.A. General
 1. Outdoor, rooftop mounted, electrically controlled, heating and cooling unit utilizing a(n) hermetic scroll compressor(s) for cooling duty and gas combustion for heating duty.
 2. Factory assembled, single-piece heating and cooling rooftop unit. Contained within the unit enclosure shall be all factory wiring, piping, controls, and special features required prior to field start-up.
 3. Unit shall use environmentally safe, Puron refrigerant.
 4. Unit shall be installed in accordance with the manufacturer’s instructions.
 5. Unit must be selected and installed in compliance with local, state, and federal codes.

23 81 19.13.B. Quality Assurance

1. Unit meets ASHRAE 90.1 minimum efficiency requirements.
2. Unit shall be rated in accordance with AHRI Standards 210/240 and 340/360.
3. Unit shall be designed to conform to ASHRAE 15, 2001.
4. Unit shall be UL-tested and certified in accordance with ANSI Z21.47 Standards and UL-listed and certified under Canadian standards as a total package for safety requirements.
5. Insulation and adhesive shall meet NFPA 90A requirements for flame spread and smoke generation.
6. Unit casing shall be capable of withstanding 500-hour salt spray exposure per ASTM B117 (scribed specimen).
7. Unit casing shall be capable of withstanding Federal Test Method Standard No. 141 (Method 6061) 5000-hour salt spray.
8. Unit shall be designed in accordance with ISO 9001:2000, and shall be manufactured in a facility registered by ISO 9001:2000.
9. Roof curb shall be designed to conform to NRCA Standards.
10. Unit shall be subjected to a completely automated run test on the assembly line. The data for each unit will be stored at the factory, and must be available upon request.
11. Unit shall be designed in accordance with UL Standard 1995, including tested to withstand rain.
12. Unit shall be constructed to prevent intrusion of snow and tested to prevent snow intrusion into the control box up to 40 mph.
13. Unit shake tested to assurance level 1, ASTM D4169 to ensure shipping reliability.
14. High Efficient Motors listed shall meet section 313 of the Energy Independence and Security Act of 2007 (EISA 2007).

23 81 19.13.C. Delivery, Storage, and Handling

1. Unit shall be stored and handled per manufacturer’s recommendations.
2. Lifted by crane requires either shipping top panel or spreader bars.
3. Unit shall only be stored or positioned in the upright position.

23 81 19.13.D. Project Conditions

1. As specified in the contract.

23 81 19.13.E. Project Conditions

1. As specified in the contract.

23 81 19.13.F. Operating Characteristics

1. Unit shall be capable of starting and running at 115°F (46°C) ambient outdoor temperature, meeting maximum load criteria of AHRI Standard 210/240 or 340/360 at ± 10% voltage.
2. Compressor with standard controls shall be capable of operation down to 40°F (4°C), ambient outdoor temperatures. Accessory winter start kit is necessary if mechanically cooling at ambient temperatures down to 25°F (-4°C).
3. Unit shall discharge supply air vertically or horizontally as shown on contract drawings.
4. Unit shall be factory configured for vertical supply & return configurations.
5. Unit shall be field convertible from vertical to horizontal airflow on all models. No special kit required on 04-14 models. Supply duct kit required for 16 size model only.
6. Unit shall be capable of mixed operation: vertical supply with horizontal return or horizontal supply with vertical return.

23 81 19.13.G. Electrical Requirements

1. Main power supply voltage, phase, and frequency must match those required by the manufacturer.

23 81 19.13.H. Unit Cabinet

1. Unit cabinet shall be constructed of galvanized steel, and shall be bonderized and coated with a pre-painted baked enamel finish on all externally exposed surfaces.
2. Unit cabinet exterior paint shall be: film thickness, (dry) 0.003 inches minimum, gloss (per ASTM D523, 60°F): 60, Hardness: H-2H Pencil hardness.
3. Evaporator fan compartment interior cabinet insulation shall conform to AHRI Standards 210/240 or 340/360 minimum exterior sweat criteria. Interior surfaces shall be insulated with a minimum 1/2-in. thick, 1 lb density, flexible fiberglass insulation, neoprene coated on the air side. Aluminum foil-faced fiberglass insulation shall be used in the heat compartment.
4. Base of unit shall have a minimum of four locations for thru-the-base gas and electrical connections (factory installed or field installed), standard.
5. Base Rail
 - a. Unit shall have base rails on a minimum of 2 sides.
 - b. Holes shall be provided in the base rails for rigging shackles to facilitate maneuvering and overhead rigging.
 - c. Holes shall be provided in the base rail for moving the rooftop by fork truck.
 - d. Base rail shall be a minimum of 16 gauge thickness.
6. Condensate pan and connections:
 - a. Shall be a sloped condensate drain pan made of a non-corrosive material.
 - b. Shall comply with ASHRAE Standard 62.
 - c. Shall use a 3/4" -14 NPT drain connection, possible either through the bottom or end of the drain pan. Connection shall be made per manufacturer's recommendations.
7. Top panel:
 - a. Shall be a single piece top panel on 04 thru 12 sizes, two piece on 14 and 16 size.
8. Electrical Connections
 - a. All unit power wiring shall enter unit cabinet at a single, factory-prepared, knockout location.
 - b. Thru-the-base capability
 - (1.) Standard unit shall have a thru-the-base electrical location(s) using a raised, embossed portion of the unit basepan.
 - (2.) Optional, factory-approved, water-tight connection method must be used for thru-the-base electrical connections.
 - (3.) No basepan penetration, other than those authorized by the manufacturer, is permitted.
9. Component access panels (standard)
 - a. Cabinet panels shall be easily removable for servicing.
 - b. Unit shall have one factory installed, tool-less, removable, filter access panel.
 - c. Panels covering control box, indoor fan, indoor fan motor, gas components (where applicable), and compressors shall have molded composite handles.
 - d. Handles shall be UV modified, composite. permanently attached, and recessed into the panel.
 - e. Screws on the vertical portion of all removable access panel shall engage into heat resistant, molded composite collars.
 - f. Collars shall be removable and easily replaceable using manufacturer recommended parts.

23 81 19.13.I. N/A

23 81 19.13.J. Coils

1. Standard Aluminum fin - Copper Tube Coils:
 - a. Standard evaporator and condenser coils shall have aluminum lanced plate fins mechanically bonded to seamless internally grooved copper tubes with all joints brazed.
 - b. Evaporator coils shall be leak tested to 150 psig, pressure tested to 450 psig, and qualified to UL 1995 burst test at 1775 psig.
 - c. Condenser coils shall be leak tested to 150 psig, pressure tested to 650 psig, and qualified to UL 1995 burst test at 1980 psig.
2. Optional Pre-coated aluminum-fin condenser coils (3 Phase Models Only):
 - a. Shall have a durable epoxy-phenolic coating to provide protection in mildly corrosive coastal environments.
 - b. Coating shall be applied to the aluminum fin stock prior to the fin stamping process to create an inert barrier between the aluminum fin and copper tube.
 - c. Epoxy-phenolic barrier shall minimize galvanic action between dissimilar metals.
3. Optional Copper-fin evaporator and condenser coils (3 Phase Models Only):
 - a. Shall be constructed of copper fins mechanically bonded to copper tubes and copper tube sheets.
 - b. Galvanized steel tube sheets shall not be acceptable.
 - c. A polymer strip shall prevent coil assembly from contacting the sheet metal coil pan to minimize potential for galvanic corrosion between coil and pan.
4. Optional E-coated aluminum-fin evaporator and condenser coils (3 Phase Models Only):
 - a. Shall have a flexible epoxy polymer coating uniformly applied to all coil surface areas without material bridging between fins.
 - b. Coating process shall ensure complete coil encapsulation of tubes, fins and headers.
 - c. Color shall be high gloss black with gloss per ASTM D523-89.
 - d. Uniform dry film thickness from 0.8 to 1.2 mil on all surface areas including fin edges.
 - e. Superior hardness characteristics of 2H per ASTM D3363-92A and cross-hatch adhesion of 4B-5B per ASTM D3359-93.
 - f. Impact resistance shall be up to 160 in.-lb (ASTM D2794-93).
 - g. Humidity and water immersion resistance shall be up to minimum 1000 and 250 hours respectively (ASTM D2247-92 and ASTM D870-92).
 - h. Corrosion durability shall be confirmed through testing to be no less than 1000 hours salt spray per ASTM B117-90.
5. Standard All Aluminum Novation Coils:
 - a. Standard condenser coils shall have all aluminum Novation Heat Exchanger Technology design consisting of aluminum multi port flat tube design and aluminum fin. Coils shall be a furnace brazed design and contain epoxy lined shrink wrap on all aluminum to copper connections.
 - b. Condenser coils shall be leak tested to 150 psig, pressure tested to 650 psig, and qualified to UL 1995 burst test at 1980 psig.
6. Optional E-coated aluminum-fin, aluminum tube condenser coils:
 - a. Shall have a flexible epoxy polymer coating uniformly applied to all coil external surface areas without material bridging between fins or louvers.
 - b. Coating process shall ensure complete coil encapsulation, including all exposed fin edges.
 - c. E-coat thickness of 0.8 to 1.2 mil with top coat having a uniform dry film thickness from 1.0 to 2.0 mil on all external coil surface areas, including fin edges, shall be provided.
 - d. Shall have superior hardness characteristics of 2H per ASTM D3363-00 and cross-hatch adhesion of 4B-5B per ASTM D3359-02.
 - e. Shall have superior impact resistance with no cracking, chipping or peeling per NSF/ANSI 51-2002 Method 10.2.

23 81 19.13.K. Refrigerant Components

1. Refrigerant circuit shall include the following control, safety, and maintenance features:
 - a. Fixed orifice metering system shall prevent mal-distribution of two-phase refrigerant by including multiple fixed orifice devices in each refrigeration circuit. Each orifice is to be optimized to the coil circuit it serves.
 - b. Refrigerant filter drier.
 - c. Service gauge connections on suction and discharge lines.
 - d. Pressure gauge access through a specially designed access port in the top panel of the unit.

2. There shall be gauge line access port in the skin of the rooftop, covered by a black, removable plug.
 - a. The plug shall be easy to remove and replace.
 - b. When the plug is removed, the gauge access port shall enable maintenance personnel to route their pressure gauge lines.
 - c. This gauge access port shall facilitate correct and accurate condenser pressure readings by enabling the reading with the compressor access panel on.
 - d. The plug shall be made of a leak proof, UV-resistant, composite material.
3. Compressors
 - a. Unit shall use one fully hermetic, scroll compressor for each independent refrigeration circuit.
 - b. Compressor motors shall be cooled by refrigerant gas passing through motor windings.
 - c. Compressors shall be internally protected from high discharge temperature conditions.
 - d. Compressors shall be protected from an over-temperature and over-amperage conditions by an internal, motor overload device.
 - e. Compressor shall be factory mounted on rubber grommets.
 - f. Compressor motors shall have internal line break thermal, current overload and high pressure differential protection.
 - g. Crankcase heaters shall not be required for normal operating range, unless provided by compressor manufacturer due to refrigerant charge limits.

23 81 19.13.L. Filter Section

1. Filters access is specified in the unit cabinet section of this specification.
2. Filters shall be held in place by a pivoting filter tray, facilitating easy removal and installation.
3. Shall consist of factory-installed, low velocity, throw-away 2-in. thick fiberglass filters.
4. Filters shall be standard, commercially available sizes.
5. Only one size filter per unit is allowed.

23 81 19.13.M. Evaporator Fan and Motor

1. Evaporator fan motor:
 - a. Shall have permanently lubricated bearings.
 - b. Shall have inherent automatic-reset thermal overload protection or circuit breaker.
 - c. Shall have a maximum continuous bhp rating for continuous duty operation; no safety factors above that rating shall be required.
2. Belt-driven Evaporator Fan:
 - a. Belt drive shall include an adjustable pitch motor pulley.
 - b. Shall use sealed, permanently lubricated ball-bearing type.
 - c. Blower fan shall be double-inlet type with forward-curved blades.
 - d. Shall be constructed from steel with a corrosion resistant finish and dynamically balanced.

23 81 19.13.N. Condenser Fans and Motors

1. Condenser fan motors:
 - a. Shall be a totally enclosed motor.
 - b. Shall use permanently lubricated bearings.
 - c. Shall have inherent thermal overload protection with an automatic reset feature.
 - d. Shall use a shaft-down design on 04 to 12 and 16 size models and shaft-up design on 14 size with rain shield.
2. Condenser Fans:
 - a. Shall be a direct-driven propeller type fan.
 - b. Shall have aluminum blades riveted to corrosion-resistant steel spiders and shall be dynamically balanced.

23 81 19.13.O. Special Features, Options and Accessories

1. Staged Air Volume System (SAV) for 2-stage cooling models only.
 - a. Evaporator fan motor:
 - (1.) Shall have permanently lubricated bearings.
 - (2.) Shall have a maximum continuous bhp rating for continuous duty operation; no safety factors above that rating.
 - (3.) Shall be Variable Frequency duty and 2-speed control.
 - (4.) Shall contain motor shaft grounding ring to prevent electrical bearing fluting damage by safely diverting harmful shaft voltages and bearing currents to ground.

2. Variable Frequency Drive (VFD). Only available on 2-speed indoor fan motor option (SAV):
 - a. Shall be installed inside the unit cabinet, mounted, wired and tested.
 - b. Shall contain Electromagnetic Interference (EMI) frequency protection.
 - c. Insulated Gate Bi-Polar Transistors (IGBT) used to produce the output pulse width modulated (PWM) waveform, allowing for quiet motor operation.
 - d. Self diagnostics with fault and power code LED indicator. Field accessory Display Kit available for further diagnostics and special setup applications.
 - e. RS485 capability standard.
 - f. Electronic thermal overload protection.
 - g. 5% swinging chokes for harmonic reduction and improved power factor.
 - h. All printed circuit boards shall be conformal coated.
3. Standard Integrated Economizers (Factory installed on 3 Phase Models Only. Field installed on all 3 and 1 Phase Models):
 - a. Integrated, gear-driven opposing modulating blade design type capable of simultaneous economizer and compressor operation.
 - b. Independent modules for vertical or horizontal return configurations shall be available. Vertical return modules shall be available as a factory installed option.
 - c. Damper blades shall be galvanized steel with composite gears. Plastic or composite blades on intake or return shall not be acceptable.
 - d. Shall include all hardware and controls to provide free cooling with outdoor air when temperature and/or humidity are below setpoints.
 - e. Shall be equipped with gear driven dampers for both the outdoor ventilation air and the return air for positive air stream control.
 - f. Standard models shall be equipped with low-leakage dampers, not to exceed 2% leakage at 1 in. wg pressure differential. Economizer controller on electromechanical units shall be Honeywell W7212 that provides:
 - (1.) Combined minimum and DCV maximum damper position potentiometers with compressor staging relay.
 - (2.) Functions with solid state analog enthalpy or dry bulb changeover control sensing.
 - (3.) Contain LED indicates for:
 - When free cooling is available
 - When module is in DCV mode
 - When exhaust fan contact is closed
 - g. Ultra low leak EconoMi\$er X system shall be available on models with SAV 2-speed Variable Frequency Drive (VFD) systems. Only available on 2-speed indoor fan motor systems with electromechanical controls or RTU Open.
 - (1.) Maximum damper leakage rate to be equal to or less than 4.0 cfm/sq. ft. at 1.0 in. w.g., meeting or exceeding ASHRAE 90.1 requirements. Economizer controller on electromechanical units shall be Honeywell W7220 that provides:
 - (2.) 2-line LCD interface screen for setup, configuration and troubleshooting
 - (3.) On-board fault detection and diagnostics
 - (4.) Sensor failure loss of communication identification
 - (5.) Automatic sensor detection
 - (6.) Capabilities for use with multiple-speed indoor fan systems
 - (7.) Utilize digital sensors: Dry bulb and Enthalpy
 - h. Shall be capable of introducing up to 100% outdoor air.
 - i. Shall be equipped with a barometric relief damper capable of relieving up to 100% return air.
 - j. Shall be designed to close damper(s) during loss-of-power situations with spring return built into motor.
 - k. Dry bulb outdoor air temperature sensor shall be provided as standard. Outdoor air sensor setpoint shall be adjustable and shall range from 40 to 100° F / 4 to 38° C. Additional sensor options shall be available as accessories.
 - l. The economizer controller shall also provide control of an accessory power exhaust unit function. Factory set at 100%, with a range of 0% to 100%.
 - m. The economizer shall maintain minimum airflow into the building during occupied period and provide design ventilation rate for full occupancy. A remote potentiometer may be used to override the damper setpoint.

- n. Dampers shall be completely closed when the unit is in the unoccupied mode.
 - o. Economizer controller shall accept a 2-10 Vdc CO₂ sensor input for IAQ/DCV control. In this mode, dampers shall modulate the outdoor air damper to provide ventilation based on the sensor input.
 - p. Compressor lockout sensor shall open at 35°F (2°C) and close closes at 50°F (10°C).
 - q. Actuator shall be direct coupled to economizer gear. No linkage arms or control rods shall be acceptable.
 - r. Economizer controller shall provide indications when in free cooling mode, in the DCV mode, or the exhaust fan contact is closed.
4. Two-Position Damper (Factory installed on 3 Phase Models Only. Field installed on all 3 and 1 Phase Models)
 - a. Damper shall be a Two-Position Damper. Damper travel shall be from the full closed position to the field adjustable %-open setpoint.
 - b. Damper shall include adjustable damper travel from 25% to 100% (full open).
 - c. Damper shall include single or dual blade, gear driven dampers and actuator motor.
 - d. Actuator shall be direct coupled to damper gear. No linkage arms or control rods shall be acceptable.
 - e. Damper will admit up to 100% outdoor air for applicable rooftop units.
 - f. Damper shall close upon indoor (evaporator) fan shutoff and/or loss of power.
 - g. The damper actuator shall plug into the rooftop unit's wiring harness plug. No hard wiring shall be required.
 - h. Outside air hood shall include aluminum water entrainment filter
 5. Manual damper
 - a. Manual damper package shall consist of damper, air inlet screen, and rain hood which can be preset to admit up to 50% outdoor air for year round ventilation.
 6. Humidi-MiZer Adaptive Dehumidification System (3 Phase Models Only).
 - a. The Humidi-MiZer Adaptive Dehumidification System shall be factory-installed in single stage 50TC04-07 and 2-stage 50TC08-16 models with RTPF (round tube plate fin) condenser coils, and shall provide greater dehumidification of the occupied space by two modes of dehumidification operations beside its normal design cooling mode:
 - (1.) Subcooling mode further subcools the hot liquid refrigerant leaving the condenser coil when both temperature and humidity in the space are not satisfied.
 - (2.) Hot gas reheat mode shall mix a portion of the hot gas from the discharge of the compressor with the hot liquid refrigerant leaving the condenser coil to create a two-phase heat transfer in the system, resulting in a neutral leaving- air temperature when only humidity in the space is not satisfied.
 - (3.) Includes Head Pressure Controller.
 7. Head Pressure Control Package
 - a. Controller shall control coil head pressure by condenser-fan speed modulation or condenser-fan cycling and wind baffles.
 - b. Shall consist of solid-state control and condenser-coil temperature sensor to maintain condensing temperature between 90°F (32°C) and 110°F (43°C) at outdoor ambient temperatures down to -20°F (-29°C).
 8. Condenser Coil Hail Guard Assembly (Factory installed on 3 Phase Models Only. Field installed on all 3 and 1 Phase Models)
 - a. Shall protect against damage from hail.
 - b. Shall be louvered design.
 9. Unit-Mounted, Non-Fused Disconnect Switch (Available on units with MOCPS of 80 amps or less):
 - a. Switch shall be factory-installed, internally mounted.
 - b. National Electric Code (NEC) and UL approved non-fused switch shall provide unit power shutoff.
 - c. Shall be accessible from outside the unit
 - d. Shall provide local shutdown and lockout capability.
 10. Convenience Outlet (3 Phase Models Only):
 - a. Powered convenience outlet.
 - (1.) Outlet shall be powered from main line power to the rooftop unit.
 - (2.) Outlet shall be powered from line side or load side of disconnect by installing contractor, as required by code. If outlet is powered from load side of disconnect, unit electrical ratings shall be UL certified and rated for additional outlet amperage.
 - (3.) Outlet shall be factory-installed and internally mounted with easily accessible 115-v female receptacle.
 - (4.) Outlet shall include 15 amp GFI receptacles with independent fuse protection.

- (5.) Voltage required to operate convenience outlet shall be provided by a factory-installed step-down transformer.
- (6.) Outlet shall be accessible from outside the unit.
- (7.) Outlet shall include a field-installed "Wet in Use" cover.
- b. Non-Powered convenience outlet.
 - (1.) Outlet shall be powered from a separate 115/120v power source.
 - (2.) A transformer shall not be included.
 - (3.) Outlet shall be factory-installed and internally mounted with easily accessible 115-v female receptacle.
 - (4.) Outlet shall include 15 amp GFI receptacles with independent fuse protection.
 - (5.) Outlet shall be accessible from outside the unit.
 - (6.) Outlet shall include a field-installed "Wet in Use" cover.
- 11. Thru-the-Base Connectors:
 - a. Kits shall provide connectors to permit electrical connections to be brought to the unit through the unit basepan.
 - b. Minimum of four connection locations per unit.
- 12. Supply Duct Cover (16 size only):
 - a. Required when field converting the factory standard vertical duct supply to horizontal duct supply configuration. One required per unit.
- 13. Propeller Power Exhaust:
 - a. Power exhaust shall be used in conjunction with an integrated economizer.
 - b. Independent modules for vertical or horizontal return configurations shall be available.
 - c. Horizontal power exhaust is shall be mounted in return ductwork.
 - d. Power exhaust shall be controlled by economizer controller operation. Exhaust fans shall be energized when dampers open past the 0-100% adjustable setpoint on the economizer control.
- 14. Roof Curbs (Vertical):
 - a. Full perimeter roof curb with exhaust capability providing separate air streams for energy recovery from the exhaust air without supply air contamination.
 - b. Formed galvanized steel with wood nailer strip and shall be capable of supporting entire unit weight.
 - c. Permits installation and securing of ductwork to curb prior to mounting unit on the curb.
- 15. Thru-the-Bottom Utility Connectors:
 - a. Kit shall provide connectors to permit gas and electrical connections to be brought to the unit through the basepan.
- 16. Outdoor Air Enthalpy Sensor:
 - a. The outdoor air enthalpy sensor shall be used to provide single enthalpy control. When used in conjunction with a return air enthalpy sensor, the unit will provide differential enthalpy control. The sensor allows the unit to determine if outside air is suitable for free cooling.
- 17. Return Air Enthalpy Sensor:
 - a. The return air enthalpy sensor shall be used in conjunction with an outdoor air enthalpy sensor to provide differential enthalpy control.
- 18. Indoor Air Quality (CO₂) Sensor:
 - a. Shall be able to provide demand ventilation indoor air quality (IAQ) control.
 - b. The IAQ sensor shall be available in duct mount, wall mount, or wall mount with LED display. The setpoint shall have adjustment capability.
- 19. Smoke detectors (factory-installed only):
 - a. Shall be a Four-Wire Controller and Detector.
 - b. Shall be environmental compensated with differential sensing for reliable, stable, and drift-free sensitivity.
 - c. Shall use magnet-activated test/reset sensor switches.
 - d. Shall have tool-less connection terminal access.
 - e. Shall have a recessed momentary switch for testing and resetting the detector.
 - f. Controller shall include:
 - (1.) One set of normally open alarm initiation contacts for connection to an initiating device circuit on a fire alarm control panel.
 - (2.) Two Form-C auxiliary alarm relays for interface with rooftop unit or other equipment.

- (3.) One Form-C supervision (trouble) relay to control the operation of the Trouble LED on a remote test/reset station.
 - (4.) Capable of direct connection to two individual detector modules.
 - (5.) Can be wired to up to 14 other duct smoke detectors for multiple fan shutdown applications.
20. Winter start kit
- a. Shall contain a bypass device around the low pressure switch.
 - b. Shall be required when mechanical cooling is required down to 25°F (-4°C).
 - c. Shall not be required to operate on an economizer when below an outdoor ambient of 40°F (4°C).
21. Time Guard
- a. Shall prevent compressor short-cycling by providing a 5-minute delay (± 2 minutes) before restarting a compressor after shutdown for any reason.
 - b. One device shall be required per compressor.
22. Electric Heat:
- a. Heating Section
 - (1.) Heater element open coil resistance wire, nickel-chrome alloy, 0.29 inches inside diameter, strung through ceramic insulators mounted on metal frame. Coil ends are staked and welded to terminal screw slots.
 - (2.) Heater assemblies are provided with integral fusing for protection of internal heater circuits not exceeding 48 amps each. Auto reset thermo limit controls, magnetic heater contactors (24 v coil) and terminal block all mounted in electric heater control box (minimum 18 ga galvanized steel) attached to end of heater assembly.
23. Disconnect Switch Bracket (16 size only)
- a. Provides a pre-engineered and sized mounting bracket for applications requiring a unit mounted fused and non-fused disconnect of greater than 100 amps. Bracket assures that no damage will occur to coils when mounting with screws and other fasteners.
24. California OSHPD Seismic Certification Label
- a. Units meet the seismic requirements of the International Code Council Evaluation Service (ICC-ES) document AC156 (Acceptance Criteria for Seismic Qualification by Shake-Table Testing of Nonstructural Components and Systems) and per International Building Code (IBC 2009) at an SDS (g) value of 2.00 z/h=1.0, Ip=1.5 and certified by independent structural engineers.
 - b. Units shall include a certification label that meets the CA OSHPD Special Seismic Certification pre-approval labeling requirements on the external chassis of the unit.
25. Hinged Access Panels
- a. Shall provide easy access through integrated quarter turn latches.
 - b. Shall be on major panels of: filters, control box, fan motor and compressor.
26. Display Kit for Variable Frequency Drive
- a. Kit allows the ability to access the VFD controller programs to provide special setup capabilities and diagnostics.
 - b. Kit contains display module, mounting bracket and communication cable.
 - c. Display Kit can be permanently installed in the unit or used on any SAV system VFD controller as needed.